

Ideas for My Home

COMPLEMENTI

TAVOLI SEDIE CONSOLLE TAVOLINI GRUPPI NOTTE



RIFLESSI®

COMPLEMENTI / COMPLEMENTS

TAVOLI
TABLES
04

CONSOLLE
CONSOLES
150

SEDIE
CHAIRS
188

MIRROR-TV
248

TAVOLINI
COFFEE TABLES
250

COMPLEMENTI NOTTE
BEDROOM FURNITURE
256

FINITURE E RIVESTIMENTI
FINISHES AND COVERING
258

RIFLESSI®



CULTURA D'IMPRESA
UN NETWORK DI
COMPETENZE,
PASSIONI,
ESPERIENZA E
PROFESSIONALITÀ

BUSINESS CULTURE
 A NETWORK OF COMPETENCE, PASSION,
 EXPERIENCE AND PROFESSIONALISM

La storia umana e imprenditoriale di Riflessi ha il sapore di una sfida vissuta sul campo. Una sfida che l'azienda ha saputo vincere grazie alla sua particolare sensibilità e ad alcune felici intuizioni: puntare su qualità e servizio, ponendo particolare attenzione nel cogliere le suggestioni che arrivano dall'esterno e nell'amalgarmarle con il proprio stile.

EN - Riflessi makes your dreams come true! Standing our ground and not backing down when faced with a challenge, our company managed to conquer the market by offering a unique customer-oriented experience comprising outstanding service, a keen eye for detail and the unique ability to incorporate new concepts into our designs.

FR - L'histoire humaine et d'entreprise de Riflessi a la saveur d'un défi vécu sur le terrain. Un défi que l'entreprise a su gagner grâce à sa sensibilité particulière et à certaines bonnes intuitions : miser sur la qualité et le service, en vieillissant particulièrement à accueillir les suggestions qui arrivent de l'extérieur et dans la façon d'amalgamer son propre style

DE - Die menschliche und unternehmerische Geschichte von Riflessi gleicht einer erfolgreich gemeisterten Herausforderung. Eine Herausforderung, die das Unternehmen durch seine besondere Sensibilität und einige richtige Intuitionen bewältigt hat: auf Qualität und Service setzen, mit besonderem Augenmerk auf äußere Eindrücke, die in den eigenen Stil miteinfließen.

ALL'INSEGNA DEL MADE IN ITALY
LA COSTANTE
RICERCA DELLA
QUALITÀ DÀ VITA A
SEMPRE NUOVI
PROGETTI

UNDER THE 'MADE IN ITALY' LABEL CONSTANT
 STRIVING FOR QUALITY PRODUCES A FLOW OF
 NEW PROJECTS

Riflessi fonda l'esperienza nella continua innovazione e crea i propri prodotti di design rigorosamente Made in Italy. Il Centro di Ricerca e Sviluppo Riflessi è il motore di tutto il processo di sviluppo dei prodotti. Al suo interno vengono ideati e progettati tutti gli arredi, si studiano soluzioni funzionali. Qui si sviluppano nuove tecnologie e s'incontrano saperi contemporanei che si fondono con competenze artigiane in grado di realizzare lavorazioni recuperate dalla tradizione. Un lavoro d'equipe che mette al centro l'unicità di ciascun individuo per realizzare un progetto comune.

EN - Based experience in the continuous innovation and from here Riflessi creates its products of design Made in Italy . Our design team creates solutions for a variety of interiors, helping our customers express their unique style through their decor choices. Our company is deeply involved in every stage of the research, design and manufacturing process. Our expertise and knowledge will help guide you towards the right choices for your specific needs as well as ensuring your decor becomes a true reflection of your inner self.

FR - Riflessi fonde son expérience dans l'innovation continue et crée ses propres produits de design rigoureusement Made in Italy. Le Centre de Recherche et Développement Riflessi est le moteur de tout le processus de développement des produits. C'est là que les ameublements sont créés et projetés et que les solutions fonctionnelles sont créées. On y développe de nouvelles technologies et c'est le lieu de rencontre des talents contemporains qui se fondent avec des compétences artisanales en mesure de réaliser des procédés récupérés de la tradition. Un travail d'équipe qui met au centre le caractère unique de chaque individu pour réaliser un projet commun.

DE -Bei Riflessi trifft kontinuierliche Innovation auf Erfahrung für Designprodukte ausschließlich Made in Italy. Im Forschungs- und Entwicklungszentrum von Riflessi nimmt der Entstehungsprozess der Produkte seinen Anfang. Hier werden alle Einrichtungen entworfen und geplant, sowie die funktionalen Aspekte ausgearbeitet. Es werden neue Technologien entwickelt und Moderne verschmilzt mit traditioneller Handwerkskunst. Eine Teamarbeit, bei der jeder Einzelne im Mittelpunkt steht, um gemeinsam ein Ziel zu erreichen.

I NUOVI FLAGSHIP STORE
UNA PRESENZA
DINAMICA NELLE
PRINCIPALI
CITTÀ ITALIANE

OUR NEW FLAGSHIP STORES
 TO THE FORE IN THE MAIN ITALIAN CITIES

Sono i punti vendita che meglio rappresentano la vision aziendale; in termini di prodotti e d'immagine sono l'espressione più genuina del Made in Italy firmato Riflessi. Si presentano come degli spazi suggestivi dove mobili e complementi diventano protagonisti ed interpreti del gusto e dello stile di vita Riflessi.

EN - These points of sale are the most representative of our corporate vision; the products and image they display are genuinely made in Italy by Riflessi. The stores comprise evocative areas where furniture and complementary items make statements about Riflessi's taste and lifestyle.

FR - Ce sont les points de vente qui représentent le mieux la vision d'entreprise ; en termes de produits et d'image, ils sont l'expression la plus authentique du Made in Italy signé Riflessi. Ils se présentent comme des espaces suggestifs où les meubles et les compléments sont au premier plan et deviennent des interprètes du goût et du style de vie Riflessi.

DE - An den Verkaufsstellen kommt die Mission des Unternehmens am besten zum Ausdruck; Produkte und Image interpretieren das Made in Italy von Riflessi in seiner reinsten Form. Suggestive Räume, in denen Möbel und Ergänzungselemente den Geschmack und den Lebensstil von Riflessi perfekt darstellen und interpretieren.



I TAVOLI

TABLES

ESTENDIBILI

EXTENDABLE

Tutti i prodotti della collezione Riflessi sono pensati per risolvere le esigenze del vivere quotidiano: si allungano, si svestono, si trasformano... Oltre ogni immaginazione!

EN - All the products in the Riflessi collection are designed to meet the needs of daily life: they can extend, be stripped and transformed... beyond imagination!

FR - Tous les produits de la collection Riflessi sont pensés pour résoudre les exigences de la vie quotidienne : ils s'allongent, se déhousent, se transforment ... Au-delà de l'imaginaire !

DE - Alle Produkte der Kollektion Riflessi sind darauf ausgelegt, die Anforderungen des täglichen Lebens zu erfüllen: sie können ausgezogen werden, sind abziehbar, verwandeln sich ... Über jede Vorstellung hinaus!

DINAMICI

DINAMIC

Gli oggetti che animano le collezioni Riflessi si rinnovano continuamente grazie alla varietà di forme, colori e materiali. La relazione tra l'oggetto, la persona e lo spazio circostante è dinamica e coinvolgente.

EN - The objects in the Riflessi collections renew themselves constantly using a variety of shapes, colours and materials. Objects, people and the space around them enter into a dynamic, all-embracing relationship.

FR - Les objets qui animent les collections Riflessi se renouvellent continuellement grâce à la variété des formes, des couleurs, des matériaux. La relation entre l'objet, la personne et l'espace environnant est dynamique et séduisante.

DE - Die belebenden Aspekte der Kollektion Riflessi erneuern sich ständig durch die Vielfalt an Formen, Farben und Materialien. Der Bezug zwischen Gegenstand, Person und umliegendem Raum ist dynamisch und mitreißend.

SOLIDI

SOLID

Solidità è sinonimo di qualità. Materiali pregiati, tecniche di lavorazioni consolidate, cura artigianale per un prodotto che dura nel tempo.

EN - Solidity is synonymous with quality. Valuable materials, tried and tested processes and craftsmanship create products that last through time.

FR - Solidité est synonyme de qualité. Des matériaux de grande qualité, des techniques de façonnage consolidées, un soin artisanal pour un produit qui dure dans le temps.

DE - Solide Beschaffenheit ist Synonym für Qualität. Hochwertige Materialien, bewährte Verarbeitungstechniken und handwerkliche Sorgfalt für ein Produkt mit einer langen Lebensdauer.

LIVING 82



PEGASO 100



CROSS 108



CUBRIC 112



ATLANTE 116



CITY 120



CLUB 124



LUXURY 126



ZED 128



GLIDE 08



TREBLE 14



MASTER 22



MANHATTAN 132



TOLEDO 140



NEW PLANO 144



UNICO 28



SHANGAI 36



ROUND - SQUARE 78



LORD 146



MITO 148



MATERIALI PER IL PIANO

MATERIALS FOR TOPS

I MATERIALI UTILIZZATI PER I PIANI SONO ECCELLENTI PER PRESTAZIONI E BELLEZZA; DISPONIBILI IN UN'AMPIA VARIETÀ CROMATICA E DI FINITURE.

EXCELLENT MATERIALS FOR PERFORMANCE AS WELL AS BEAUTY
AVAILABLE IN A HUGE VARIETY OF COLOURS AND FINISHES

LES MATERIAUX UTILISÉS POUR LES PLANS SONT EXCELLENTS POUR PRESTATION ET
BEAUTE; DISPONIBLES DANS UNE LARGE VARIÉTÉ DE COULEURS ET FINITIONS.

DIE FÜR DIE TISCHPLATTEN VERWENDETEN MATERIALIEN SIND HERAUSRAGEND
IN BEZUG AUF LEISTUNGSMERKMALE UND SCHÖNHEIT; SIE SIND IN EINER
UMFANGREICHEN AUSWAHL AN FARBEN UND AUSFÜHRUNGEN ERHÄLTlich.

LAVORATO ARTIGIANALMENTE IL LEGNO

ARTISAN PROCESSED: WOOD

Riflessi da sempre sceglie e seleziona tranciati di qualità che vengono lavorati con maestria artigianale.

EN - Riflessi has always chosen and selected top quality sliced wood and skilfully crafted it.

FR - Riflessi choisit depuis toujours et sélectionne des tranches de qualité qui sont travaillées avec expertise artisanale.

DE - Riflessi verarbeitet schon immer ausgesuchte Qualitätsfurniere mit hoher Handwerkskunst.

MATERIALE DI ALTA GAMMA LA CERAMICA

HIGH-END MATERIAL: CERAMICS

Negli ultimi anni la ceramica si è rivelata un materiale altamente performante per soddisfare esigenze di praticità in casa senza rinunciare a stile ed eleganza.

EN - Recently ceramics have become popular as an excellent, practical material for the home that is also stylish and elegant.

FR - Au cours des dernières années, la céramique s'est révélée comme étant un matériau hautement performant pour satisfaire les exigences de praticité à la maison sans renoncer au style ni à l'élégance.

DE - In den letzten Jahren hat sich Keramik als ein besonders leistungsstarkes Material erwiesen, das in der Wohnung alle Anforderungen an Zweckmäßigkeit erfüllt, ohne auf Stil und Eleganz zu verzichten.

PURO E RESISTENTE IL CRISTALLO

PURE AND STRONG: GLASS

Riflessi ha scelto in maniera consapevole e cosciente di utilizzare solo vetri temperati e con angoli raggiati, al fine di garantire la sicurezza di chi acquista un tavolo o una consolle Riflessi.

EN - Riflessi has deliberately chosen to use only toughened glass with rounded corners so that the safety of whoever buys a Riflessi table or console is protected.

FR - Riflessi a choisi de manière responsable et consciente de n'utiliser que des verres trempés et avec des angles rayonnés, afin de garantir la sécurité de ceux qui achètent une table ou une console Riflessi.

DE - Riflessi hat sich bewusst dafür entschieden, nur gehärtetes Glas und abgerundete Ecken zu verwenden, da beim Kauf von Tischen oder Konsolentischen von Riflessi Sicherheit an erster Stelle steht.

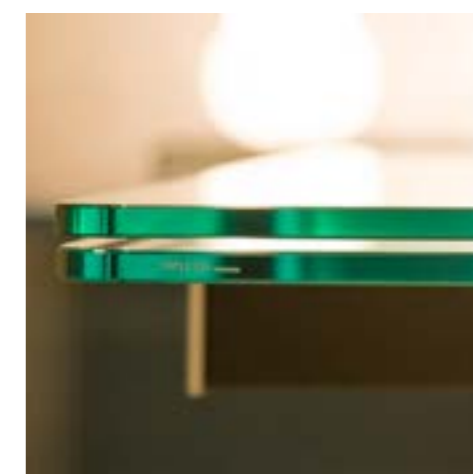
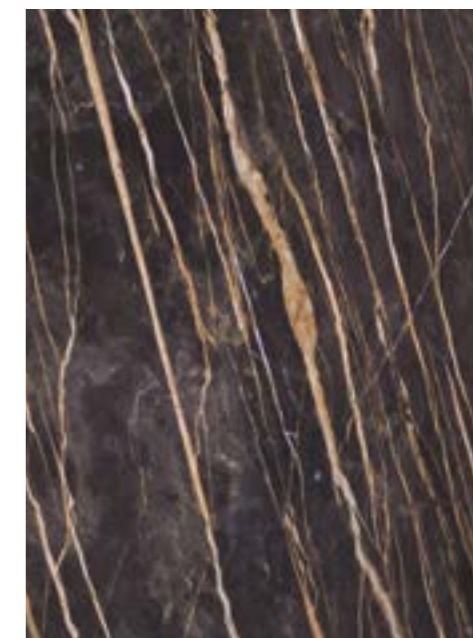

TAVOLO FISSO - FIXED TABLE

GLIDE

PIANI IN CRISTALLO
GLASS TOPS

Design Egidio Panzera

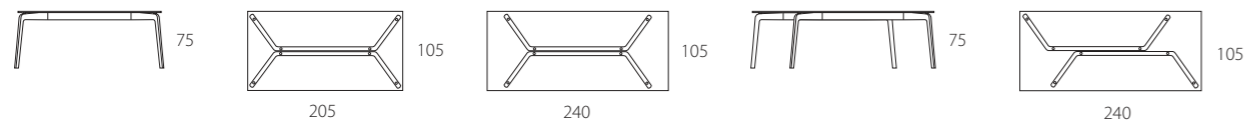

Tavolo fisso con struttura lavorata a mano in massello di rovere tinto miele o coke. Speciale incollaggio tra il piano in cristallo e i cilindri di supporto. Piano in cristallo trasparente temperato sp. 12 mm, extrachiaro o fumé.

EN - Fixed table with hand-worked structure in honey or coke stained solid oak. The glass top and support cylinders are joined by a special adhesive. Top in 12 mm thick, transparent or fumé toughened glass.

FR - Table fixe avec structure travaillée à main en bois massif de chêne rouvre teint miel ou coke. Collage spécial entre le plan en verre et les cylindres de support. Plan en verre transparent et trempé ép. 12 mm, extra clair ou fumé.

DE - Tisch mit fester Tischplatte und handgearbeitetem Gestell aus massiver Eiche in der Farbe Honig oder Coke. Spezielle Verleimung zwischen Kristallplatte und Tragzylindern. Tischplatte aus gehärtetem transparentem Kristall St. 12 mm extrahell oder Fumé.



GLIDE





TAVOLO FISSO - FIXED TABLE

TREBLE

PIANI IN CRISTALLO O CERAMICA
GLASS OR CERAMIC TOPS

Designed by Riflessi Lab

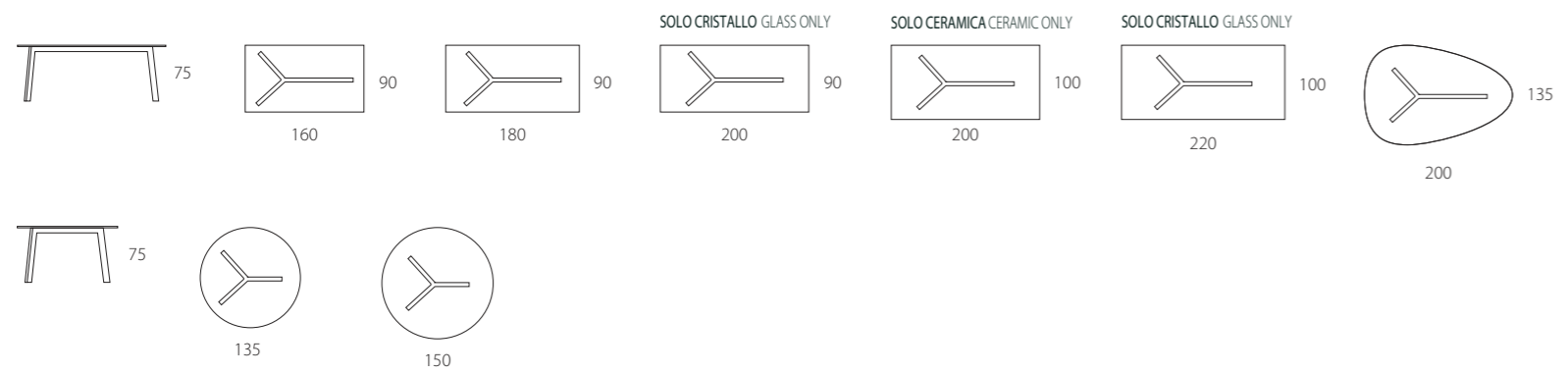

Tavolo con base in alluminio verniciato grafite, bianco, titanio oottone spazzolato a mano. Piano in cristallo trasparente temperato sp. 12 mm, extrachiaro o fumé. Piano in ceramica bisellata stratificata su vetro sp. 12 mm in bianco Statuario, pietra Savoia grigio, pietra Savoia antracite, Noir Desir lucido o calacatta oro lucido.

EN - Table with aluminium base, painted graphite, white, titanium or hand brushed brass. Top in 12 mm thick, transparent toughened glass extra light or fumé. Bevelled top in ceramic layered onto 12 mm thick in Statuary white, Savoy stone grey, Savoy stone anthracite, glossy Noir Desir or glossy Calacatta gold.

FR - Table avec base en aluminium verni graphite, blanc, titanio ou laiton brossé à main. Plan en verre transparent trempé ép. 12 mm extra clair ou fumé. Plan en céramique biseauté stratifié sur verre ép. 12 mm en blanc Statuaire, pierre Savoie Gris, pierre Savoie anthracite, Noir Desir brillant ou Calacatta or brillant.

DE - Tisch mit Gestell aus lackiertem Aluminium in Graphitgrau, Weiß, Titan oder handgebürstetem Messing. Tischplatte aus transparentem Kristall St. 12 mm Extrahell oder Fumé. Tischplatte aus Schichtkeramik auf Glas mit geschliffenen Kanten St. 12 mm in Weiß Statuario, Stein Savoyen Grau, Stein Savoyen Anthrazit, Noir Desir Hochglanz oder Calacatta Gold Hochglanz.









TAVOLO FISSO - FIXED TABLE

MASTER

PIANI IN CERAMICA, LEGNO O CRISTALLO
CERAMIC, WOODEN OR GLASS TOPS

Designed by Molteni / Baron Associati

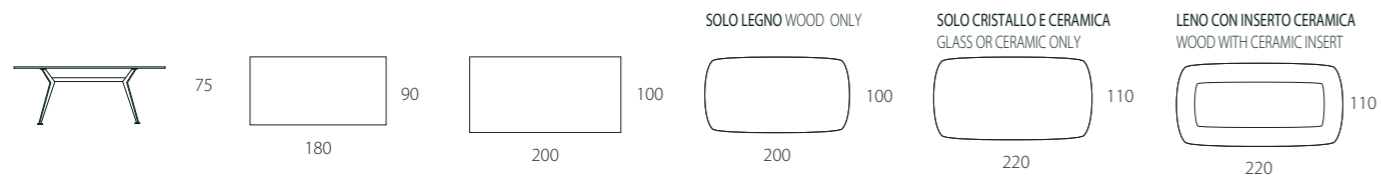

Tavolo con base in alluminio e acciaio, verniciata grafite o ottone spazzolato a mano. Piano in ceramica bisellata stratificata su vetro sp. 12 mm in bianco statuario, pietra Savoia grigio, pietra Savoia antracite, Noir Desir lucido o Calacatta oro lucido. Piano in cristallo trasparente temperato sp. 12 mm, extrachiaro o fumé. Piano in legno sp. 30 mm bisellato in noce canaletto o rovere coke termotrattato, rovere poro aperto tinto noce, bianco, naturale, miele, tabacco, wengè, grigio, cenere o ciliegio. Piano in rovere coke termotrattato o noce canaletto con inserto in ceramica a scelta nei cinque colori.

EN - Table with aluminium and steel base, painted graphite or hand brushed brass. Bevelled top in ceramic layered onto 12 mm thick glass in Statuary white, Savoy stone grey, Savoy stone anthracite, glossy Noir Desir or glossy Calacatta gold. Top in 12mm thick transparent, extra clear or fumé toughened glass. Top in 30mm thick bevelled wood in the finishes Canaletto walnut or thermo-treated coke oak, open pore oak stained walnut, white, natural, honey, tobacco, wengè, grey, ash or cherrywood. Top in thermo-treated Coke oak or Canaletto walnut with ceramic insert in a choice of five colours.

FR - Table avec base en aluminium et acier, verni graphite ou laiton brossé à main.. Plan en céramique biseauté stratifiée sur verre ép. 12 mm en blanc Statuaire, pierre Savoie Gris, pierre Savoie anthracite, Noir Desir brillant ou Calacatta or brillant. Plan en verre transparent trempé ép. 12 mm, extra clair ou fumé. Plan en bois ép. 30 mm biseauté en noyer Canaletto ou Chêne rouvre Coke thermo-traité, Chêne rouvre pore ouvert teint noyer, blanc, naturel, miele, tabac, wengè, gris, cendre ou cerisier. Plan en Chêne rouvre Coke thermo-traité ou noyer canaletto avec insert en céramique choisi entre les 5 couleurs.

DE - Tisch mit Gestell aus Aluminium und Stahl in Graphitgrau oder handgebürstetem Messing. Tischplatte aus Schichtkeramik auf Glas mit schrägen Kanten St. 12 mm in Weiß Statuario, Stein Savoyen Grau, Stein Savoyen Anthrazit, Noir Desir Hochglanz oder Calacatta Gold Hochglanz. Tischplatte aus gehärtetem transparentem Kristall St. 12 mm extrahell oder Fumè. Tischplatte aus Holz St. 30 mm mit schrägen Kanten aus amerikanischem Nussbaum oder Eiche Coke wärmebehandelt, Eiche offenporig in der Farbe Nussbaum, Weiß, Natur, Honig, Tabak, Wenge, Grau, Asche oder Kirschbaum. Tischplatte aus Eiche Coke wärmebehandelt oder amerikanischem Nussbaum mit Intarsie aus Keramik nach Wahl in den fünf Farben.







TAVOLO FISSO - FIXED TABLE

UNICO

TAVOLO IN TECNORIL® O LEGNO
TABLE IN TECNORIL® OR WOOD

Designed by Riflessi Lab

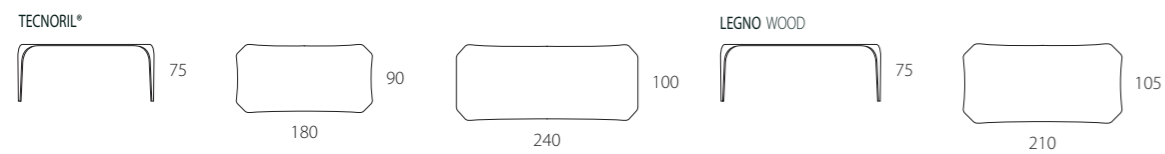

Tavolo monolite in Technoril® nei colori bianco, caffelatte, grigio o in legno con esterno in rovere coke termotrattato e interno in rovere miele.

EN - Monolite Technoril® table in Bianco, Caffelatte or Grigio, or in wood with thermo-treated coke oak on the outside and Miele oak on the inside.

FR - Table monolithique en Technoril® dans les couleurs: Bianco, Caffelatte, Grigio ou en bois avec extérieur en chêne rouvre coke thermo-traité et intérieur en chêne rouvre Miele.

DE - Monolith-Tisch aus Technoril® in den Farben Bianco, Caffelatte, Grigio oder aus Holz mit Außenseite in Eiche Coke wärmebehandelt und Innenseite in Eiche Miele.



UNICO





TAVOLI PERSONALIZZABILI

CUSTOMISABLE TABLES

MASSIMA LIBERTÀ COMPOSITIVA:
SONO NUMEROSE LE VARIANTI FORMALI DEL PIANO E LE
DIVERSE POSSIBILITÀ DI ABBINARLO ALLA BASE

GREAT FREEDOM OF COMPOSITION:
THE PLAN HAS SEVERAL VARIANTS AND DIFFERENT WAYS
OF COORDINATING WITH BASE UNITS.

LIBERTÉ DE COMPOSITION MAXIMUM :
NOMBREUSES SONT LES VARIANTES FORMELLES DU
PLATEAU AINSI QUE LES POSSIBILITÉS DE L'ASSEMBLER À
L'ÉLÉMENT BAS.

HÖCHSTE GESTALTUNGSFREIHEIT:
TISCHPLATTEN IN ZAHLREICHEN FORMEN UND
VERSCHIEDENE KOMBINATIONSMÖGLICHKEITEN MIT DEM
GESTELL.



SHANGAI



LIVING



PEGASO

01 SCEGLI IL BASAMENTO

CHOOSE THE BASE
CHOISISSEZ LE BAS - WÄHLEN SIE DAS GESTELL AUS

02 SCEGLI LA FORMA DEL PIANO

CHOOSE THE SHAPE OF THE TOP
CHOISISSEZ LA FORME DU PLAN - WÄHLEN SIE DIE FORM DER TISCHPLATTE AUS

03 CARATTERIZZALO CON I MATERIALI

CHOOSE THE MATERIALS FOR THE TOP
CHOISISSEZ LES MATERIAUX POUR LE PLAN - WÄHLEN SIE DAS MATERIAL DER TISCHPLATTE AUS

LE FORME DEL PIANO

SHAPES OF THE TOP:

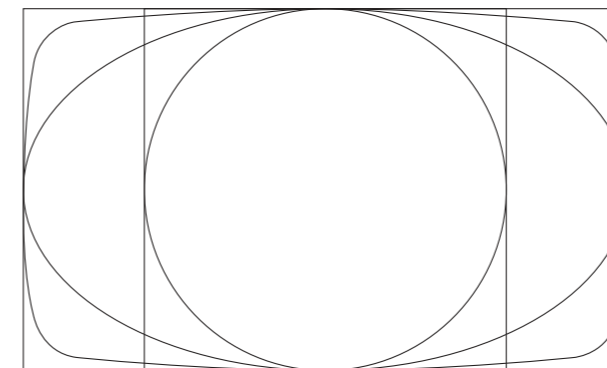

QUADRATO - SQUARED
RETTANGOLARE - RECTANGULAR
OVALE - OVAL
ROTONDO - ROUND
A BOTTE - SHAPED EDGES



LEGNO

WOOD

BORDO IRREGOLARE SP. 50 mm
SHAPED EDGE THICKNESS 50 mm
BORD FACONNE EP. 50 mm
GEFORMTE KANTE ST. 50 mm

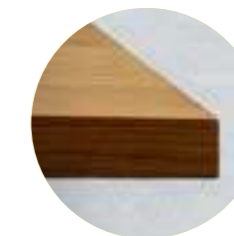
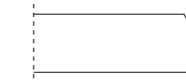

BORDO REGOLARE SP. 50 mm
REGULAR EDGE THICKNESS 50 mm
BORD REGULIERE EP. 50 mm
REGELMASSIGE KANTE ST. 50 mm

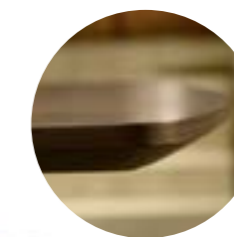
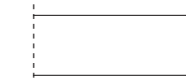

BORDO BISELLATO SP. 30 mm
BEVELED EDGE THICKNESS 30 mm
BORD BISEAUTE EP. 30 mm
SCHRÄGE KANTE ST. 30 mm



CERAMICA

CERAMIC

PIANO CERAMICA Sp. 12/15 mm
CERAMIC TOP THICKNESS 12-15 mm
PLAN EN CERAMIQUE EP. 12/15 mm
TISCHPLATTE AUS KERAMIK ST. 12/15 mm

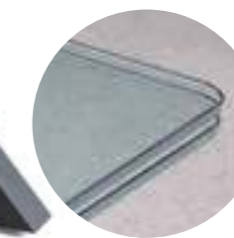
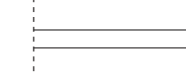

CRISTALLO

GLASS

PIANO CRISTALLO SP. 12-15 mm
GLASS TOP THICKNESS 12-15 mm
PLAN EN VERRE EP. 12-15 mm
TISCHPLATTE AUS GLAS ST. 12-15 mm

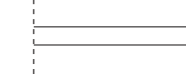

La dimensione del piano può essere anche su misura.
Top dimensions can be customized.
La dimension du plan peut être aussi sur mesure.
Die tischplatte kann auch nach mass angefertigt werden.



SHANGAI

PIANI IN CERAMICA
CERAMIC TOP

Designed by Riflessi Lab

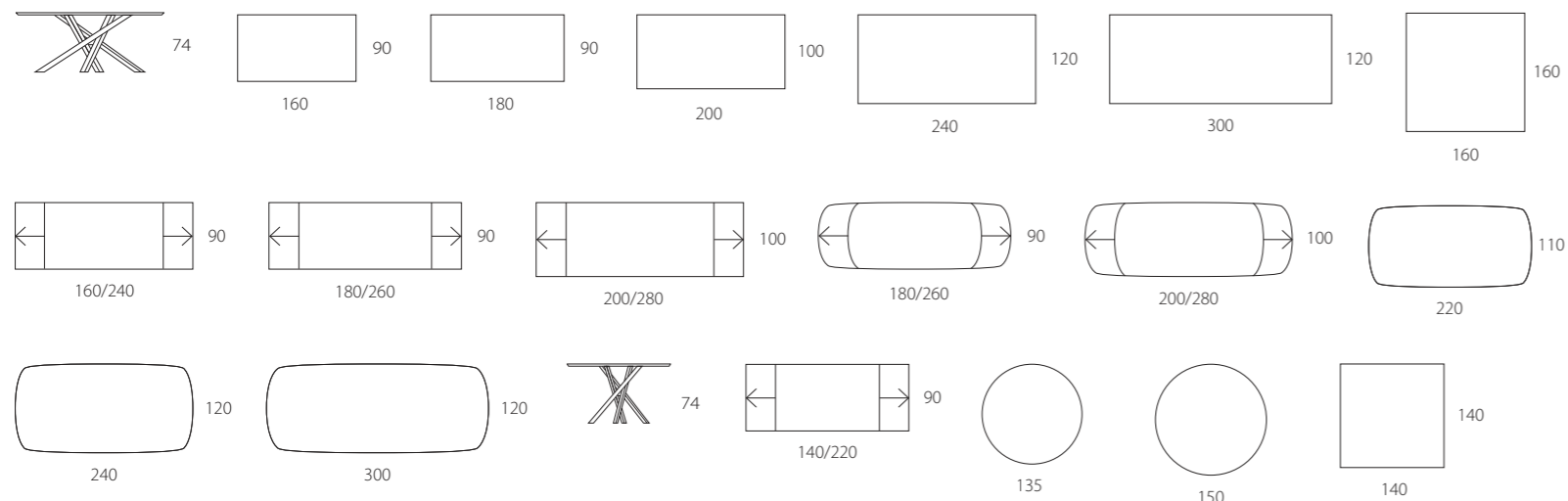

Tavolo con base composta da gambe inclinate e sovrapposte tra loro in maniera asimmetrica in alluminio verniciato bianco, grafite, oro rosa, ottone spazzolato a mano o rivestito in acciaio inox specchiante. Solo per le versioni con piano fisso, base in rovere nelle finiture a campionario. Piano in ceramica bisellata stratificata su vetro spessore 12/15 mm in bianco statuario, pietra Savoia grigio o antracite, Noir Desir lucido, Calacatta oro lucido.

EN - Table with base comprising aluminium, asymmetrically superimposed, inclined legs painted in the colours white, graphite, pink gold, hand brushed brass finish, or covered in mirror finish stainless steel. For versions with fixed tops only, oak base in our catalogue finishes. Bevelled top in ceramic layered onto 12/15 mm thick glass in Statuary white, Savoy stone grey, Savoy stone anthracite, glossy Noir Desir or glossy Calacatta gold.

FR - Table avec base composée de pieds inclinés et superposés entre eux en manière asymétrique en aluminium verni blanc, graphite, or rose, laiton brossé à main ou revêtu en acier inox réfléchissant. Seulement pour les versions avec plan fixe, base en chêne rouvre dans les finitions d'échantillons. Plan en céramique biseauté stratifiée sur verre épaisseur 12/15 mm en blanc Statuaire, pierre Savoie Gris, pierre Savoie anthracite, Noir Desir brillant ou Calacatta or brillant.

DE - Tisch mit Gestell aus schrägen und asymmetrisch übereinander liegenden Beinen aus lackiertem Aluminium in Weiß, Graphitgrau, Rosegold, handgebürstetem Messing oder beschichtet mit verspiegeltem Edelstahl. Nur für Modelle mit fester Tischplatte, Gestell aus Eiche in den Ausführungen der Musterkollektion. Tischplatte aus Schichtkeramik auf Glas Stärke 12/15 mm in Weiß Statuario, Stein Savoyen Grau, Stein Savoyen Anthrazit, Noir Desir Hochglanz oder Calacatta Gold Hochglanz.









SHANGAI

PIANI IN LEGNO CON INSERTO CERAMICA
WOODEN TOPS WITH CERAMIC INSERT

Designed by Riflessi Lab

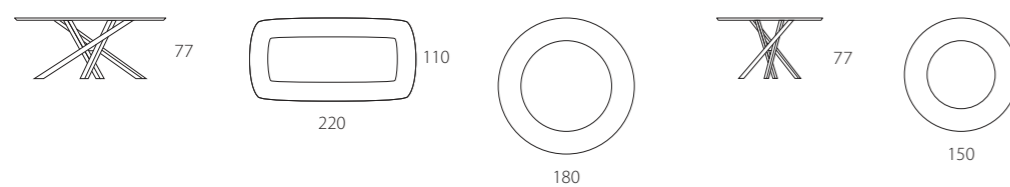

Tavolo con base composta da gambe inclinate e sovrapposte tra loro in maniera asimmetrica in alluminio verniciato bianco, grafite, oro rosa, ottone spazzolato a mano, rivestito in acciaio inox specchiante o in rovere nelle finiture a campionario. Piano bisellato sp. 30 mm in rovere coke termotrattato o noce canaletto. Inserto in ceramica in bianco Statuario, pietra Savoia grigio, pietra Savoia antracite, Noir Desir lucido o Calacatta oro lucido.

EN - Table with base comprising aluminium, asymmetrically superimposed, inclined legs painted in the colours white, graphite, pink gold, hand brushed brass finish, or covered in mirror finish stainless steel, or in oak with our catalogue finishes. 30 mm thick bevelled top in thermo-treated coke oak or Canaletto walnut. Ceramic insert in Statuary white, Savoy stone grey, Savoy stone anthracite, glossy Noir Desir or glossy Calacatta gold.

FR - Table avec base composée de pieds inclinés et superposés entre eux en manière asymétrique en aluminium verni blanc, graphite, or rose, brossé à main, revêtu en acier inox réfléchissant ou en chêne rouvre dans les finitions d'échantillons. Plan biseauté ép. 30 mm en chêne rouvre coke thermo-traité ou noyer canaletto. Insert en céramique en blanc Statuaire, pierre Savoie Gris, pierre Savoie anthracite, Noir Desir brillant ou Calacatta or brillant.

DE - Tisch mit Gestell aus schrägen und asymmetrisch übereinander liegenden Beinen aus lackiertem Aluminium in Weiß, Graphitgrau, Rosegold, handgebürstetem Messing, beschichtet mit verspiegeltem Edelstahl oder aus Eiche in den Ausführungen der Musterkollektion. Tischplatte mit schrägen Kanten St. 30 mm in Eiche Coke wärmebehandelt oder amerikanischem Nussbaum. Intarsie aus Keramik in Weiß Statuario, Stein Savoyen Grau, Stein Savoyen Anthrazit, Noir Desir Hochglanz oder Calacatta Gold Hochglanz.









IL VASSOIO CENTROTAVOLA GIREVOLE LAZY SUSAN È IN LEGNO NOCE CANALETTO, ROVERE COKE O IN CERAMICA NEI 5 COLORI PUÒ ESSERE ABBINATO A QUALSIASI TAVOLO.

THE LAZY SUSAN TABLE CENTRE TRAY IS IN CANALETTO WALNUT WOOD, COKE OAK OR CERAMIC IN A CHOICE OF FIVE COLOURS. CAN BE USED ON ANY TABLE.

LE PLATEAU CENTRE DE TABLE TOURNANT LAZY SUSAN EST EN BOIS NOYER CANALETTO, CHENE ROUVRE COKE OU EN CERAMIQUE DANS LES 5 COULEURS. IL PEUT ETRE ASSOCIE A TOUT TYPE DE TABLE.

DIE DREHBARE ABLAGE IN DER MITTE DES TISCHS LAZY SUSAN AUS AMERIKANISCHEM NUSSBAUMHOLZ, EICHE COKE ODER AUS KERAMIK IN DEN 5 FARBEN KANN MIT JEDEM TISCH KOMBINIERT WERDEN.



SHANGAI

PIANI IN LEGNO BISELLATI spessore 30 mm
WOODEN TOPS thickness 30 mm WITH BEVELED EDGES

Designed by Riflessi Lab

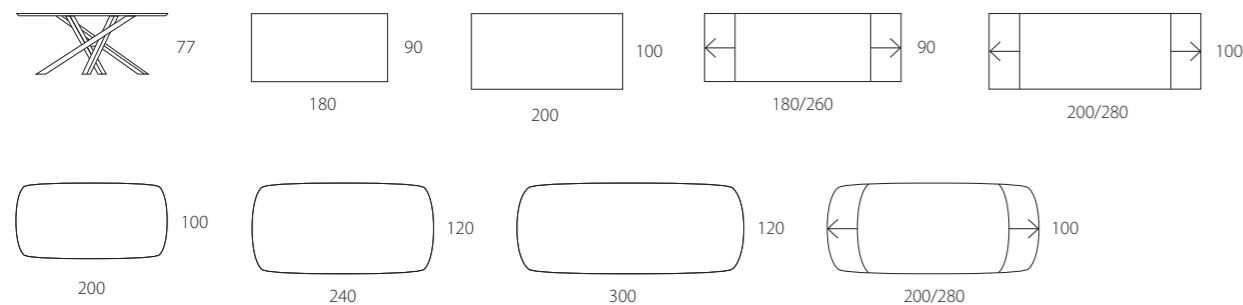

Tavolo con base composta da gambe inclinate e sovrapposte tra loro in maniera asimmetrica in alluminio verniciato bianco, grafite, oro rosa, ottone spazzolato a mano, rivestito in acciaio inox specchiante, rivestito in pietra arenaria Rivergrey o ArabiK o in rovere nelle finiture a campionario. Piano bisellato sp. 30 mm in rovere poro aperto tinto noce, bianco, naturale, miele, tabacco, wengè, grigio, cenere o ciliegio; noce canaletto o rovere coke termotrattato.

EN - Table with base comprising aluminium, asymmetrically superimposed, inclined legs painted in the colours white, graphite, pink gold, hand brushed brass finish, or covered in mirror finish stainless steel, Rivergrey or ArabiK sandstone or in oak with our catalogue finishes. 30 mm thick bevelled top in open pore oak in the colours walnut, white, natural, honey, tobacco, wengè, grey, ash or cherrywood. canaletto walnut or thermo-treated coke oak.

FR - Table avec base composée de pieds inclinés et superposés entre eux en manière asymétrique en aluminium verni blanc, graphite, or rose, laiton brossé à main, revêtu en Grès Rivergrey ou ArabiK, ou en chêne rouvre dans les finitions d'échantillons. Plan biseauté ép. 30 mm en chêne rouvre pore ouvert couleur noyer, blanc, naturel, miele, tabac, wengè, gris, cendre ou cerisier; noyer Canaletto ou chêne rouvre coke thermo-traité.

DE - Tisch mit Gestell aus schrägen und asymmetrisch übereinander liegenden Beinen aus lackiertem Aluminium in Weiß, Graphitgrau, Rosegold, handgebürstetem Messing, beschichtet mit verspiegeltem Edelstahl, beschichtet mit Sandstein Rivergrey oder ArabiK oder aus Eiche in den Ausführungen der Musterkollektion. Tischplatte mit schrägen Kanten St. 30 mm aus Eiche offenporig in der Farbe Nussbaum, Weiß, Natur, Honig, Tabak, Wenge, Grau, Asche oder Kirschbaum; amerikanischer Nussbaum oder Eiche Coke wärmebehandelt.





SHANGAI

PIANI IN LEGNO CON BORDI IRREGOLARI spessore 50 mm
WOODEN TOPS thickness 50 mm WITH SHAPED EDGES

Designed by Riflessi Lab

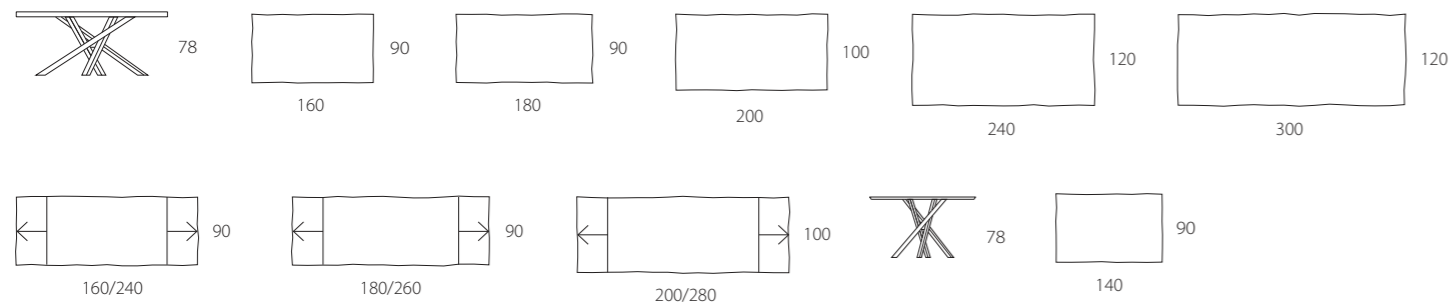

Tavolo con base composta da gambe inclinate e sovrapposte tra loro in maniera asimmetrica in alluminio verniciato bianco, grafite, oro rosa, ottone spazzolato a mano, rivestito in acciaio inox specchiante, rivestito in pietra arenaria Rivergrey o ArabiK o in rovere nelle finiture a campionario. Piano con bordi irregolari sp. 50 mm in rovere poro aperto tinto noce, bianco, naturale, miele, tabacco, wengè, grigio, cenere o ciliegio; noce canaletto o rovere coke termotrattato.

EN - Table with base comprising aluminium, asymmetrically superimposed, inclined legs painted in the colours white, graphite, pink gold, hand brushed brass finish, or covered in mirror finish stainless steel, Rivergrey or ArabiK sandstone, or in oak with our catalogue finishes. 50 mm thick top with shaped edges, in open pore oak in the colours walnut, white, natural, honey, tobacco, wengè, grey, ash or cherrywood; Canaletto walnut or thermo-treated coke oak.

FR - Table avec base composée de pieds inclinés et superposés entre eux en manière asymétrique en aluminium verni blanc, graphite, or rose, brossé à main, revêtu en Grès Rivergrey ou ArabiK ou en chêne rouvre dans les finitions d'échantillons. Plan avec bords façonnés ép. 50 mm en chêne rouvre pore ouvert couleur noyer, blanc, naturel, miel, tabac, wengè, gris, cendre ou cerisier; noyer Canaletto ou chêne rouvre coke thermo-traité.

DE - Tisch mit Gestell aus schrägen und asymmetrisch übereinander liegenden Beinen aus lackiertem Aluminium in Weiß, Graphitgrau, Rosegold, handgebürstetem Messing, beschichtet mit verspiegeltem Edelstahl, beschichtet mit Sandstein Rivergrey oder Arabik oder aus Eiche in den Ausführungen der Musterkollektion. Tischplatte mit geformten Kanten St. 50 mm aus Eiche offenporig in der Farbe Nussbaum, Weiß, Natur, Honig, Tabak, Wenge, Grau, Asche oder Kirschbaum; amerikanischer Nussbaum oder Eiche Coke wärmebehandelt.









SHANGAI

PIANI IN CRISTALLO
GLASS TOPS

Designed by Riflessi Lab

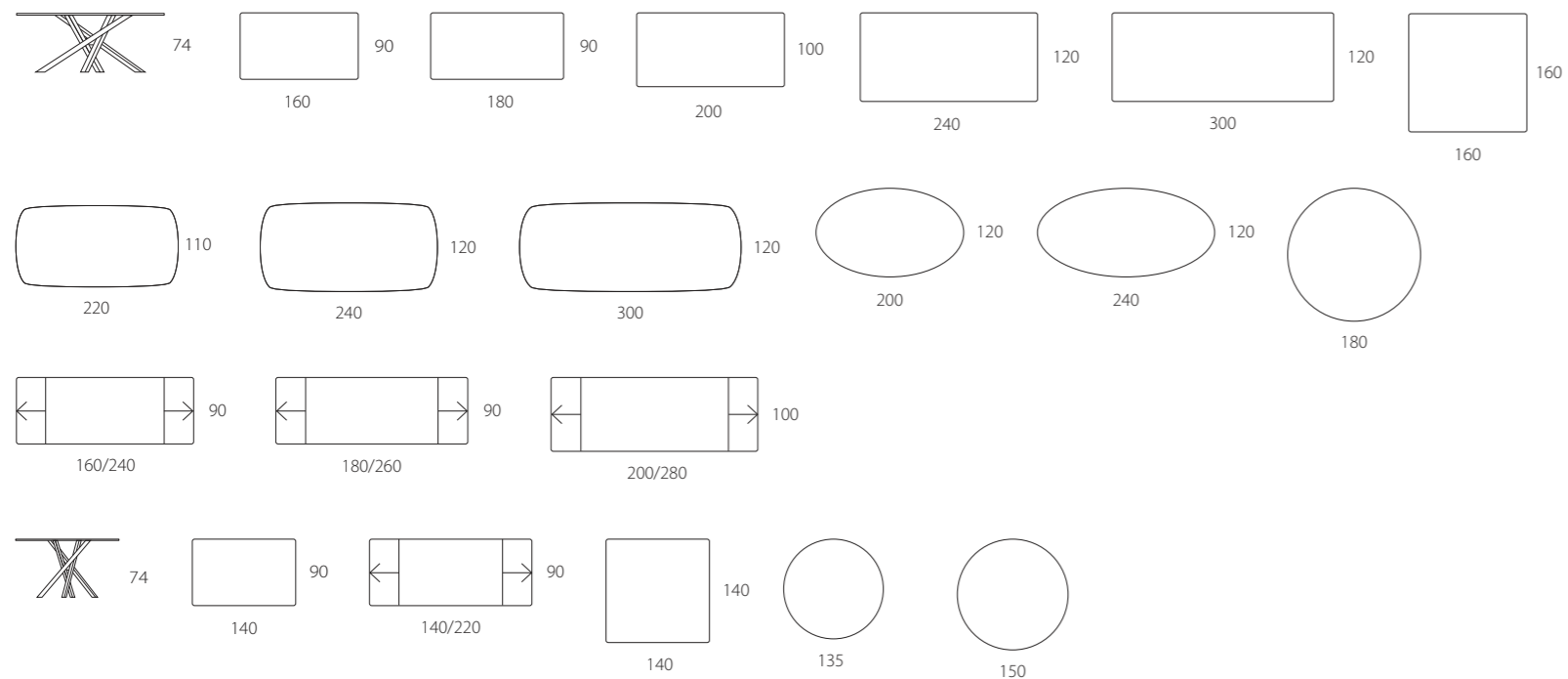

Tavolo con base composta da gambe inclinate e sovrapposte tra loro in maniera asimmetrica in alluminio verniciato bianco, grafite, oro rosa, ottone spazzolato a mano o rivestito in acciaio inox specchiante. Solo per le versioni con piano fisso, base in pietra arenaria Rivergrey o ArabiK o in rovere nelle finiture a campionario.. Piano in cristallo trasparente temperato sp. 12/15 mm, extrachiaro o fumé.

EN - Table with base comprising aluminium, asymmetrically superimposed, inclined legs painted in the colours white, graphite, pink gold, hand brushed brass finish, or covered in mirror finish stainless steel. For versions with fixed tops only, Rivergrey or ArabiK sandstone, or in oak with our catalogue finishes. Top in 12/15 mm thick transparent, extra clear or fumé toughened glass.

FR - Table avec base composée de pieds inclinés et superposés entre eux en manière asymétrique verni blanc, graphite, or rose, brossé à main, revêtu en acier inox réfléchissant. Seulement pour les versions avec plan fixe, base en Grès Rivergrey ou ArabiK ou en chêne rouvre dans les finitions d'échantillons. Plan en verre transparent trempé ép. 12/15 mm, extra clair ou fumé.

DE - Tisch mit Gestell aus schrägen und asymmetrisch übereinander liegenden Beinen aus lackiertem Aluminium in Weiss, Graphitgrau, Rosegold, handgebürstetem Messing oder beschichtet mit Sandstein Rivergrey oder ArabiK oder aus Eiche in den Ausführungen der Musterkollektion. Nur für Modelle mit fester Tischplatte, Gestell aus Eiche in den Ausführungen der Musterkollektion. Tischplatte aus gehärtetem transparentem Kristall St. 12/15 mm, extrahell oder Fumé.

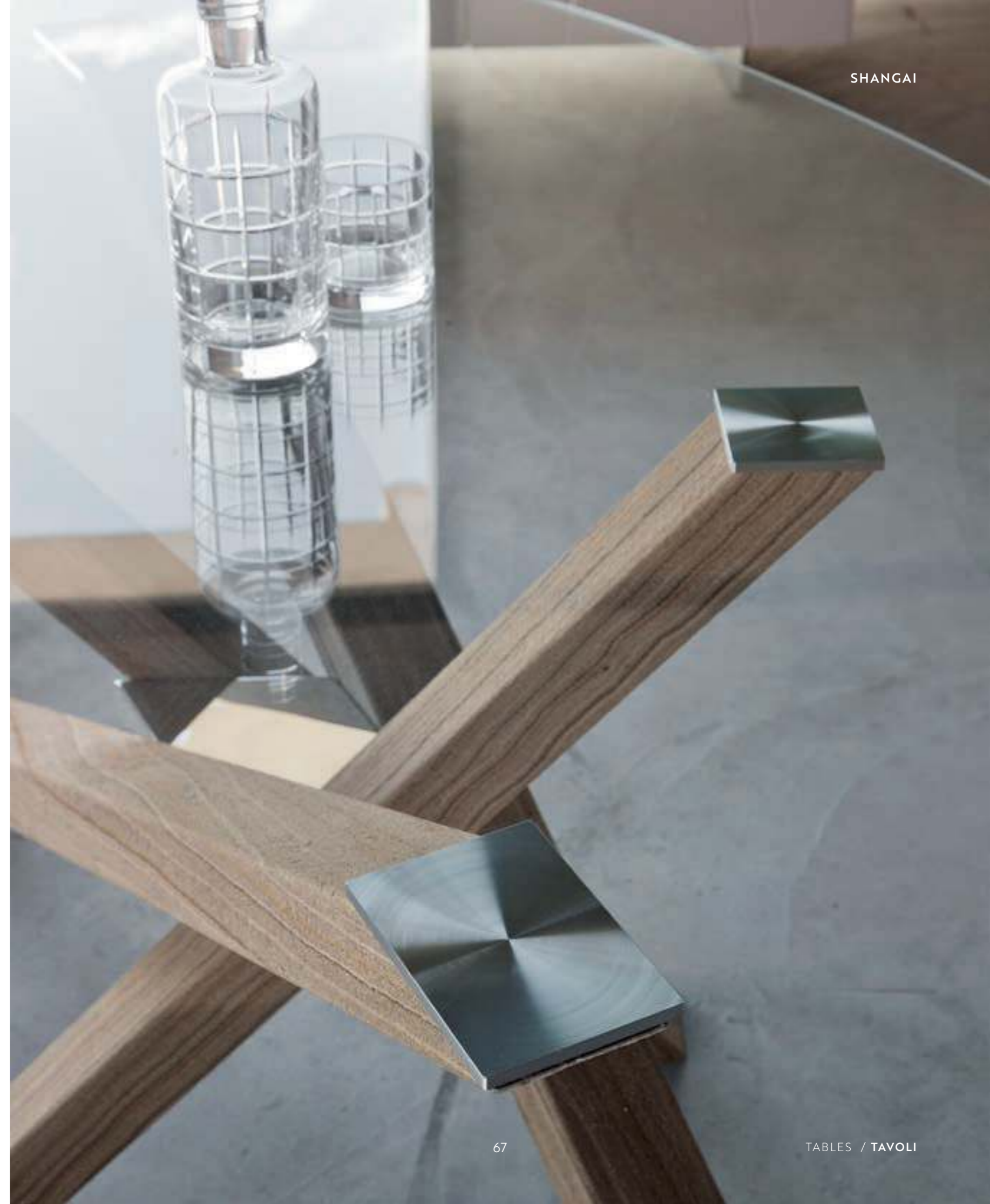









TAVOLO FISSO - FIXED TABLE

SHANGAI

SHANGAI

LIMITED EDITION

BASE METACRILATO TRASPARENTE E PIANO IN CRISTALLO EXTRACHIARO
TRANSPARENT METACRYLATE BASE WITH EXTRA CLEAR GLASS TOP

Designed by Riflessi Lab

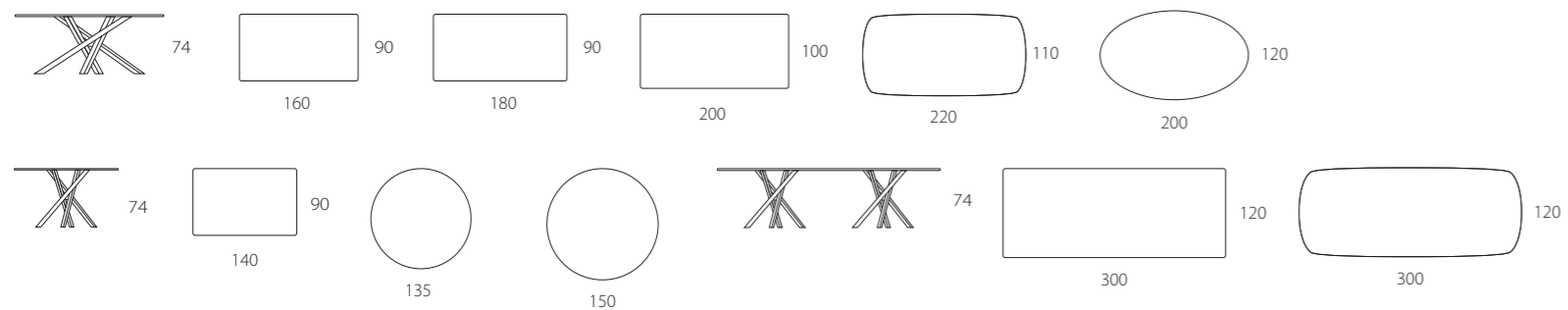

Tavolo con base composta da gambe inclinate e sovrapposte tra loro in maniera asimmetrica in metacrilato trasparente. Snodo centrale in acciaio inox. Piano in cristallo trasparente temperato sp. 12 mm extrachiario o fumé.

EN - Table with base comprising transparent methacrylate, asymmetrically superimposed, inclined legs. Stainless steel central articulated joint. Top in 12 mm thick transparent, extra clear or fumé toughened glass.

FR - Table avec base composée de pieds inclinés et superposés entre eux manière asymétrique en méthacrylate transparent. Joint central en acier inox. Plan en verre transparent trempé ép. 12 mm, extra clair ou fumé.

DE - Tisch mit Gestell aus schrägen und asymmetrisch übereinander liegenden Beinen aus transparentem Methacrylat. Gelenk in der Mitte aus Edelstahl. Tischplatte aus gehärtetem transparentem Kristall St. 12 mm, extrahell oder Fumè.



ROUND & SQUARE

PIANI IN CRISTALLO O CERAMICA
GLASS OR CERAMIC TOPS

Designed by Riflessi Lab

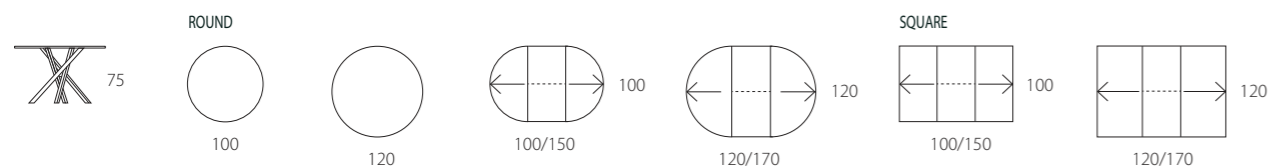

Tavolo con base composta da gambe inclinate e sovrapposte tra loro in maniera asimmetrica in alluminio verniciato bianco, grafite, oro rosa, ottone spazzolato a mano o rivestito in acciaio inox specchiante. Piano in cristallo extrachiaro temperato sp.10 mm retroverniciato bianco opaco o in ceramica bianco statuario, pietra Savoia grigio, pietra Savoia antacite, Noir Desir o Calacatta oro lucido. Allunghe interne in legno laccato opaco bianco o grafite.

EN - Table with base comprising aluminium, asymmetrically superimposed, inclined legs painted in the colours white, graphite, pink gold, hand brushed brass finish or covered in mirror finish stainless steel. Top in 10mm thick extra clear toughened glass, back painted matt white or in Statuary white, Savoy stone grey, Savoy stone anthracite, glossy Noir Desir or glossy Calacatta gold. Internal extensions matt lacquered white or graphite.

FR - Table avec base composée de pieds inclinés et superposés entre eux en manière asymétrique en aluminium verni blanc, graphite, or rose, laiton brossé à main ou revêtu en acier inox réfléchissant. Plan en verre extra clair trempé ép. 10 mm verni arrière blanc mat ou en blanc Statuaire, pierre Savoie Gris, pierre Savoie anthracite, Noir Desir brillant ou Calacatta or brillant. Rallonges internes en bois laqué mat blanc et graphite.

DE - Tisch mit Gestell aus schrägen und asymmetrisch übereinander liegenden Beinen aus lackiertem Aluminium in Weiss, Graphitgrau, Rosegold, handgebürstetem Messing oder beschichtet mit verspiegeltem Edelstahl. Tischplatte aus gehärtetem extrahellem Kristall St. 10 mm rückseitig lackiert in Weiß Matt oder aus Keramik in Weiß Statuario, Stein Savoyen Grau, Stein Savoyen Anthrazit, Noir Desir Hochglanz oder Calacatta Gold Hochglanz. Verlängerungen im Inneren aus matt lackiertem Holz in Weiß oder Graphitgrau.





LIVING

PIANI IN CERAMICA
CERAMIC TOPS

Designed by Riflessi Lab

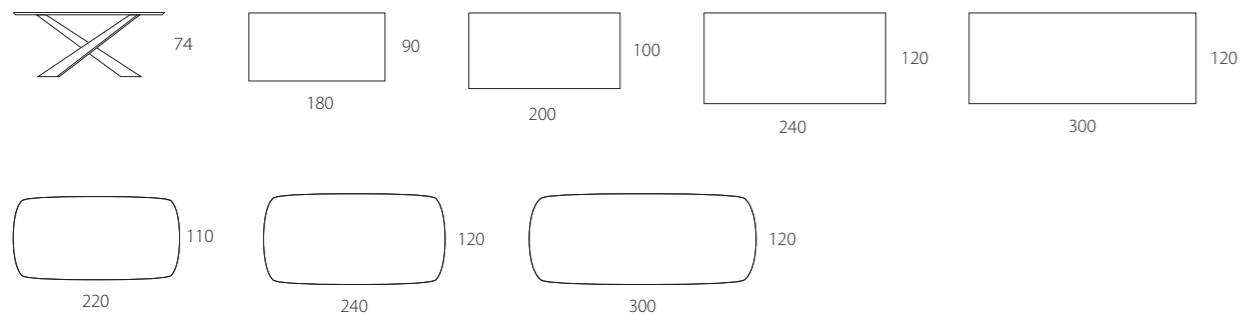

Tavolo con base caratterizzata da due gambe inclinate e sovrapposte fra loro in maniera asimmetrica in metallo verniciato grafite, ottone spazzolato a mano. Piano in ceramica bisellata stratificata su vetro spessore 12/15 mm in bianco statuario, pietra Savoia grigio o antracite, Noir Desir lucido, Calacatta oro lucido.

EN - Table featuring two inclined metal legs asymmetrically superimposed, painted in graphite or with hand brushed brass finish. Bevelled top in ceramics layered onto 12/15mm thick glass in Statuary white, Savoy stone grey, Savoy stone anthracite, glossy Noir Desir or glossy Calacatta gold.

FR - Table avec base caractérisée par deux pieds inclinés et superposés entre eux en manière asymétrique en métal verni graphite, laiton brossé à main. Plan en céramique biseauté stratifiée sur verre épaisseur 12/15 mm en blanc Statuaire, pierre Savoie anthracite, Noir Desir brillant ou Calacatta or brillant.

DE - Tisch mit Gestell aus zwei schrägen und asymmetrisch übereinander liegenden Beinen aus lackiertem Metall in Graphitgrau, handgebürstetem Messing. Tischplatte aus Schichtkeramik auf Glas Stärke 12/15 mm in Weiß Statuario, Stein Savoyen Grau, Stein Savoyen Anthrazit, Noir Desir Hochglanz oder Calacatta Gold Hochglanz.



LIVING

PIANO IN LEGNO CON INSERTO IN CERAMICA
WOODEN TOP WITH CERAMIC INSERT

Designed by Riflessi Lab

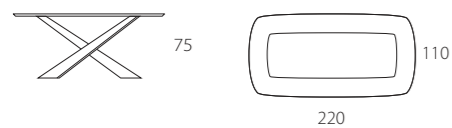

Tavolo con base caratterizzata da due gambe inclinate e sovrapposte fra loro in maniera asimmetrica in metallo verniciato grafite, ottone spazzolato a mano. Piano bisellato sp. 30 mm in rovere coke termotrattato o noce canaletto. Inserto in ceramica in bianco Statuario, pietra Savoia grigio, pietra Savoia antracite, Noir Desir lucido o Calacatta oro lucido.

EN - Table featuring a base comprising two inclined metal legs asymmetrically superimposed, painted in graphite or with hand brushed brass finish. 30mm thick bevelled top in thermo-treated coke oak or American Walnut. Ceramic insert in Statuary white, Savoy stone grey, Savoy stone anthracite, glossy Noir Desir or glossy Calacatta gold.

FR - Table avec base caractérisée par pieds inclinés et superposés entre eux en manière asymétrique en métal verni graphite, laiton brossé à main. Plan biseauté ép. 30 mm en chêne rouvre Coke thermo-traité ou noyer Canaletto. Insert en céramique en blanc Statuaire, pierre Savoie Gris, pierre Savoie anthracite, Noir Desir brillant ou Calacatta or brillant.

DE - Tisch mit Gestell aus zwei schrägen und asymmetrisch übereinander liegenden Beinen aus lackiertem Metall in Graphitgrau oder handgebürstetem Messing. Tischplatte mit schrägen Kanten St. 30 mm in Eiche Coke wärmebehandelt oder amerikanischem Nussbaum. Intarsie aus Keramik in Weiß Statuario, Stein Savoyen Grau, Stein Savoyen Anthrazit, Noir Desir Hochglanz oder Calacatta Gold Hochglanz.



LIVING

PIANI IN LEGNO BISELLATO spessore 30 mm
WOODEN TOPS thickness 30 mm WITH BEVELED EDGES

Designed by Riflessi Lab

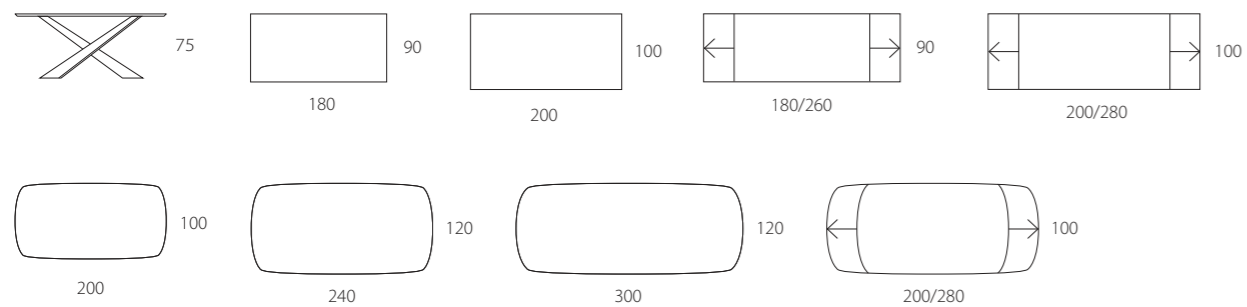

Tavolo con base caratterizzata da due gambe inclinate e sovrapposte fra loro in maniera asimmetrica in metallo verniciato grafite, ottone spazzolato a mano o rivestito in pietra arenaria Rivergrey o Arabik. Piano bisellato sp. 30 mm noce canaletto o rovere coke termotrattato; rovere poro aperto tinto noce, bianco, naturale, miele, tabacco, wengè, grigio, cenere o ciliegio.

EN - Table featuring a base comprising two inclined metal legs asymmetrically superimposed, painted in graphite, hand brushed brass finish, or covered in Rivergrey or Arabik sandstone. 30 mm thick bevelled top in American Walnut or thermo-treated coke oak; open pore oak stained in the colours walnut, white, natural, honey, tobacco, wengè, grey, ash or cherrywood.

FR - Table avec base caractérisée par deux pieds inclinés et superposés entre eux en manière asymétrique en métal verni graphite, laiton brossé à main ou revêtu en Pietra arenaria Rivergrey ou Arabik. Plan biseauté ép. 30 mm Noyer Canaletto ou chêne rouvre coke thermo-traité; chêne rouvre pore ouvert couleur noyer, blanc, naturel, miel, tabac, wengè, gris, cendre ou cerisier.

DE - Tisch mit Gestell aus zwei schrägen und asymmetrisch übereinander liegenden Beinen aus lackiertem Metall in Graphitgrau, handgebürstetem Messing oder beschichtet mit Sandstein Rivergrey oder Arabik. Tischplatte mit schrägen Kanten St. 30 mm aus amerikanischem Nussbaum oder Eiche Coke wärmebehandelt, Eiche offenporig in der Farbe Nussbaum, Weiß, Natur, Honig, Tabak, Wenge, Grau, Asche oder Kirschbaum.



LIVING

PIANI IN LEGNO CON BORDI IRREGOLARI spessore 50 mm
WOODEN TOPS thickness 50 mm WITH SHAPED EDGES

Designed by Riflessi Lab

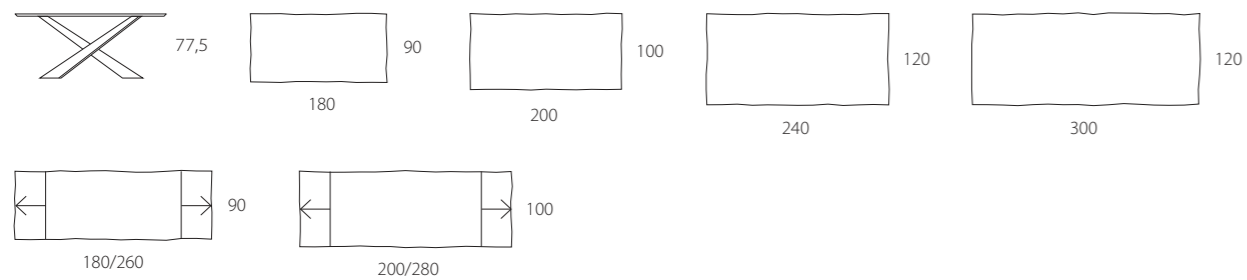

Tavolo con base caratterizzata da due gambe inclinate e sovrapposte fra loro in maniera asimmetrica in metallo verniciato grafite, ottone spazzolato a mano o rivestito in pietra arenaria Rivergrey o Arabik. Piano con bordi irregolari sp. 50 mm in rovere poro aperto tinto noce, bianco, naturale, miele, tabacco, wengè, grigio, cenere o ciliegio; noce canaletto o rovere coke termotrattato.

EN - Table featuring a base comprising two inclined metal legs asymmetrically superimposed, painted in graphite, hand brushed brass finish, or covered in Rivergrey or Arabik sandstone. 50 mm thick top with shaped edges, in open pore oak stained in the colours walnut, white, natural, honey, tobacco, wengè, grey, ash or cherrywood; American walnut or thermo-treated coke oak.

FR - Table avec base caractérisée par deux pieds inclinés et superposés entre eux en manière asymétrique en métal verni graphite, laiton brossé à main ou revêtu en grès Arabik ou RivergreyK. Plan avec bords façonnés ép. 50 mm en chêne rouvre pore ouvert couleur noce, bianco, naturale, miele, tabacco, wengè, grigio, cenere ou ciliegio; noyer canaletto ou chêne rouvre coke thermo-traité.

DE - Tisch mit Gestell aus zwei schrägen und asymmetrisch übereinander liegenden Beinen aus lackiertem Metall in Graphitgrau, handgebürstetem Messing oder beschichtet mit Sandstein Rivergrey oder Arabik. Tischplatte mit geformten Kanten St. 50 mm aus Eiche offenporig in der Farbe Nussbaum, Weiß, Natur, Honig, Tabak, Wenge, Grau, Asche oder Kirschbaum; amerikanischer Nussbaum oder Eiche Coke wärmebehandelt.







TAVOLO FISSO - FIXED TABLE

LIVING

PIANI IN CRISTALLO
GLASS TOPS

Designed by Riflessi Lab



Tavolo con base caratterizzata da due gambe inclinate e sovrapposte fra loro in maniera asimmetrica in metallo verniciato grafite, ottone spazzolato a mano o rivestito in pietra arenaria Rivergrey o Arabik. Piano in cristallo trasparente temperato sp. 12/15 mm, extrachiaro o fumé.

EN - Table featuring a base comprising two inclined metal legs asymmetrically superimposed, painted in graphite, hand-brushed brass finish or covered in Rivergrey or Arabik sandstone. Top in 12/15 mm thick transparent toughened glass, extra clear or fumé.

FR - Table avec base caractérisée par deux pieds inclinés et superposés entre eux en manière asymétrique en métal verni grafite, laiton brossé à main ou revêtu en grès Arabik ou Rivergrey. Plan en verre transparent trempé ép. 12/15 mm, extra clair ou fumé.

DE - Tisch mit Gestell aus zwei schrägen und asymmetrisch übereinander liegenden Beinen aus lackiertem Metall in Graphitgrau, handgebürstetem Messing oder beschichtet mit Sandstein Rivergrey oder Arabik. Tischplatte aus gehärtetem transparentem Kristall St. 12/15 mm, extrahell oder Fumé.







TAVOLO FISSO - FIXED TABLE

PEGASO

PIANI IN CERAMICA
CERAMIC TOPS

Designed by Riflessi Lab

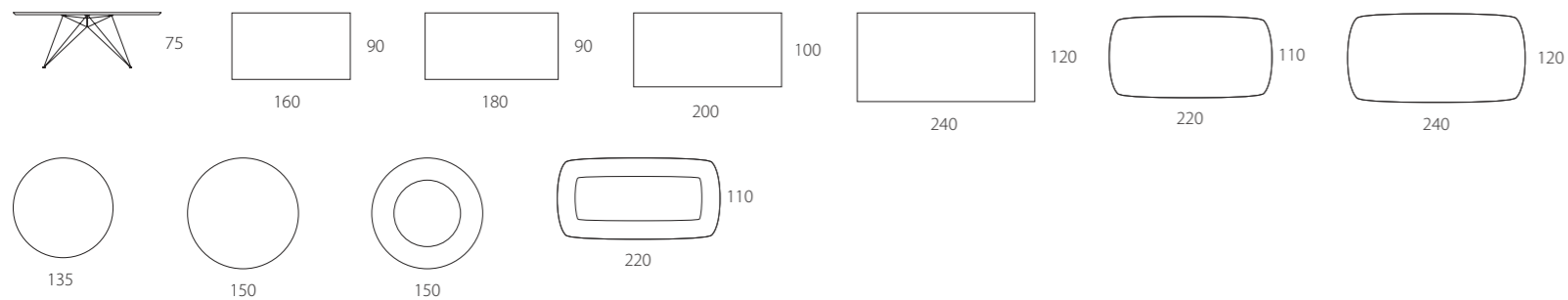

Tavolo con base in metallo verniciato grafite. Piano in ceramica bisellata stratificata su vetro spessore 12/15 mm in bianco statuario, pietra Savoia grigio o antracite, Noir Desir lucido, Calacatta oro lucido. Piano bisellato sp. 30 mm in rovere coke termotrattato e noce canaletto con inserto in ceramica nei 5 colori.

EN - Table with grafite painted metal base. Top in bevelled ceramics layered onto 12/15mm thick glass, in Statuary white, Savoy stone grey, Savoy stone anthracite, glossy Noir Desir or glossy Calacatta gold. 30 mm thick bevelled top in thermo-treated coke oak and Canaletto walnut with ceramic insert in a choice of five colours.

FR - Table avec base en métal verni graphite. Plan en céramique biseauté stratifiée sur verre épaisseur 12/15 mm en blanc Statuaire, pierre Savoie Gris, pierre Savoie anthracite, Noir Desir brillant ou Calacatta or brillant. Plan biseauté ép. 30 mm en chêne rouvre coke thermo-traité et noyer Canaletto avec inserts en céramique en 5 couleurs.

DE - Tisch mit Gestell aus lackiertem Metall in Graphitgrau. Tischplatte aus Schichtkeramik auf Glas Stärke 12/15 mm in Weiß Statuario, Stein Savoyen Grau, Stein Savoyen Anthrazit, Noir Desir Hochglanz oder Calacatta Gold Hochglanz. Tischplatte mit schrägen Kanten St. 30 mm aus Eiche Coke wärmebehandelt und amerikanischem Nussbaum mit Intarsie aus Keramik in den fünf Farben.





PEGASO

PIANI IN LEGNO
WOODEN TOPS

Designed by Riflessi Lab



Piano LEGNO BISELLATO Sp. 30 mm / WOODEN TOP Th. 30 mm WITH BEVELED EDGES

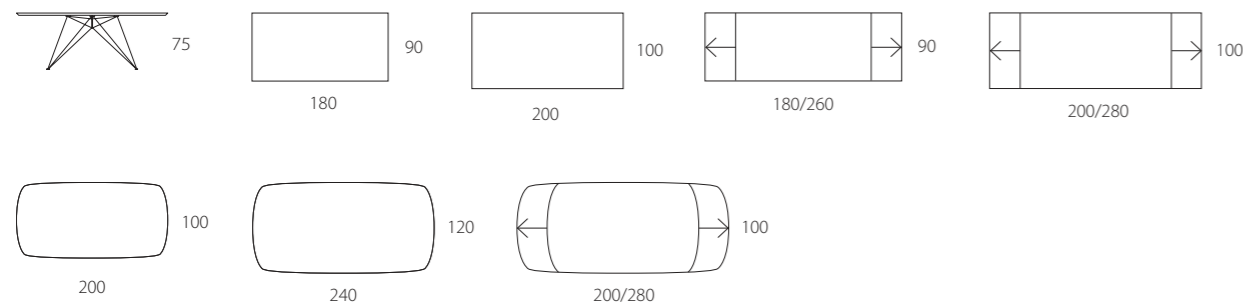

Piano LEGNO CON BORDI IRREGOLARI Sp.50 mm / WOODEN TOP Th. 50 mm WITH SHAPED EDGES

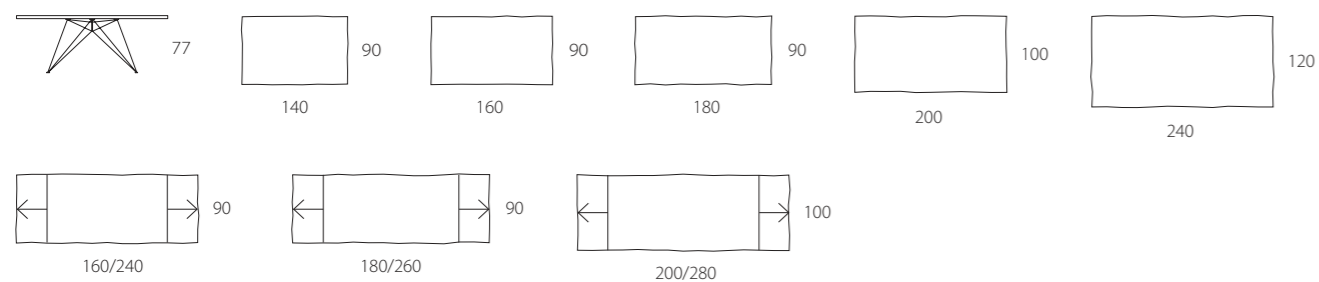

Tavolo con base in metallo verniciato grafite. Piano bisellato sp. 30 mm rovere coke termotrattato, rovere poro aperto tinto noce, bianco, naturale, miele, tabacco, wengè, grigio, cenere o ciliegio; noce canaletto. Piano con bordi irregolari sp. 50 mm in rovere poro aperto tinto noce, bianco, naturale, miele, tabacco, wengè, grigio, cenere o ciliegio; noce canaletto o rovere coke termotrattato.

EN - Table with graphite painted metal base. 30mm thick beveled top in thermo-treated coke oak, walnut stained open pore oak, walnut, white, natural, honey, tobacco, wengè, grey, ash or cherrywood. Canaletto walnut. 50mm thick top with shaped edges in open pore oak stained in the colours walnut, white, natural, honey, tobacco, wengè, grey, ash or cherrywood; American Walnut or thermo-treated coke oak.

FR - Table avec base en métal verni grafite. Plan biseauté ép. 30 mm chêne rouvre coke thermo-traité, chêne rouvre pore ouvert couleur noyer, blanc, naturel, miel, tabac, wengè, gris, cendre ou cerisier; noyer canaletto. Plan avec bords façonnés ép. 50 mm en chêne rouvre pore ouvert couleur noyer, blanc, naturel, miele, tabac, wengè, gris, cendre ou cerisier; noyer Canaletto ou chêne rouvre coke thermo-traité.

DE - Tisch mit Gestell aus lackiertem Metall in Graphitgrau. Tischplatte mit schrägen Kanten St. 30 mm in Eiche Coke wärmebehandelt, Eiche offenporig in der Farbe Nussbaum, Weiß, Natur, Honig, Tabak, Wenge, Grau, Asche oder Kirschbaum; amerikanischer Nussbaum. Tischplatte mit geformten Kanten St. 50 mm aus Eiche offenporig in der Farbe Weiß, Natur, Honig, Tabak, Wenge, Grau, Asche oder Kirschbaum; amerikanischer Nussbaum oder Eiche Coke wärmebehandelt.



TAVOLO FISSO - FIXED TABLE

PEGASO

PIANI IN CRISTALLO
GLASS TOPS

Designed by Riflessi Lab

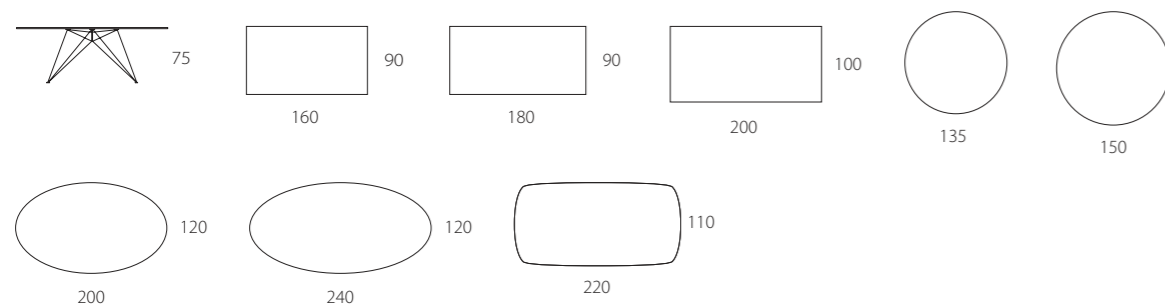

Tavolo con base in metallo verniciato grafite. Piano in cristallo trasparente temperato sp. 12 mm, extrachiaro o fumé.

EN - Table with graphite painted metal base. Top in 12mm thick transparent toughened glass, extra clear or fumé.

FR - Table avec base en métal verni graphite. Plan en verre trempé extra clair ou fumé.

DE - Tisch mit Gestell aus lackiertem Metall in Graphitgrau. Tischplatte aus gehärtetem transparentem Kristall St. 12 mm, extrahell oder Fumè.



CROSS

PIANI IN CERAMICA
CERAMIC TOPS

Designed by Riflessi Lab

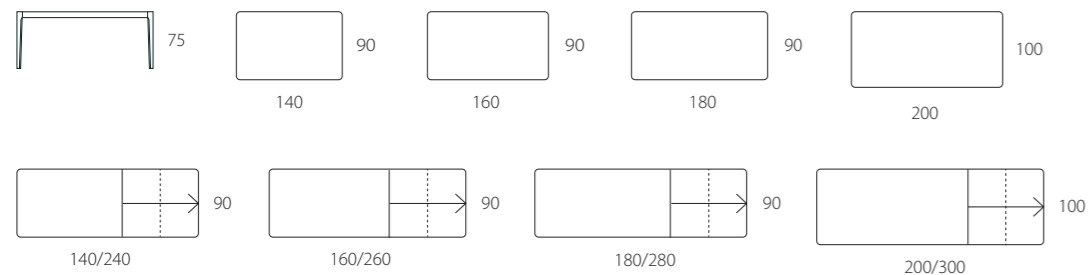

Tavolo con struttura in legno frassino tinto noce, frassino coke termotrattato; frassino poro aperto tinto bianco o miele. Piano in ceramica bianco Statuario, pietra Savoia grigio, pietra Savoia antracite, Noir Desir lucido o Calacatta oro lucido. Allunghe in legno laccato opaco bianco o antracite.

EN - Table with structure in walnut stained ash wood, thermo-treated coke ash wood; open pore ash wood stained white or honey. Top in Statuary white, Savoy stone grey, Savoy stone anthracite, glossy Noir Desir or glossy Calacatta gold. Extensions in matt lacquered white or anthracite wood.

FR - Table avec structure en bois frêne couleur noyer, frêne coke thermo-traité; frêne pore ouvert couleur blanc ou miele. Plan en blanc Statuaire, pierre Savoie Gris, pierre Savoie anthracite, Noir Desir brillant ou Calacatta or brillant. Rallonges en bois laqué mat blanc ou antracite.

DE - Tisch mit Gestell aus Eschenholz in der Farbe Nussbaum, Esche Coke wärmebehandelt; Esche offenporig in der Farbe Weiß oder Honig. Tischplatte aus Keramik in Weiß Statuario, Stein Savoyen Grau, Stein Savoyen Anthrazit, Noir Desir Hochglanz oder Calacatta Gold Hochglanz. Verlängerungen aus matt lackiertem Holz in Weiß oder Anthrazit.





TAVOLO FISSO - FIXED TABLE

CUBRIC

PIANO IN LEGNO
WOODEN TOPS

Designed by Riflessi Lab

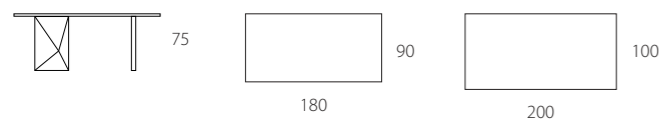

Tavolo con base composta da un piede piegato a diamante in acciaio inox specchiante o verniciato ottone spazzolato a mano, ed un piede in cristallo trasparente extrachiaro temperato, spessore 19mm. Piano con bordi irregolari sp. 50 mm in rovere poro aperto tinto noce, bianco, naturale, miele, tabacco, wengè, grigio, cenere, ciliegio; noce canaletto o rovere coke termotrattato.

EN - Table with a base comprising foot bent into a diamond shape in mirror finish stainless steel or painted hand brushed brass finish, and a 19mm thick extra clear transparent toughened glass foot. 50 mm thick top with shaped edges in open pore oak in the colours walnut, white, natural, honey, tobacco, wengè, grey, ash or cherrywood; American walnut or thermo-treated coke oak.

FR - Table avec base composée de un pied plié en forme de diamant en acier inox réfléchissant ou verni laiton brossé à main, et un pied en verre transparent extra clair trempé, épaisseur 19mm. Plan avec bords façonnés ép. 50 mm en chêne rouvre pore ouvert couleur noyer, blanc, naturel, miel, tabac, wengè, gris, cendre ou cerisier; noyer Canaletto ou chêne rouvre coke thermo-traité.

DE - Tisch mit Gestell aus einem Fuß in Diamantform aus verspiegeltem Edelstahl oder lackiert in handgebürstetem Messing und einem Fuß aus gehärtetem extrahellem transparentem Kristall, Stärke 19mm. Tischplatte mit geformten Kanten St. 50 mm aus Eiche offenporig in der Farbe Nussbaum, Weiß, Natur, Honig, Tabak, Wenge, Grau, Asche oder Kirschbaum; amerikanischer Nussbaum oder Eiche Coke wärmebehandelt.





ATLANTE

TAVOLO IN LEGNO
WOODEN TABLE

Designed by Riflessi Lab

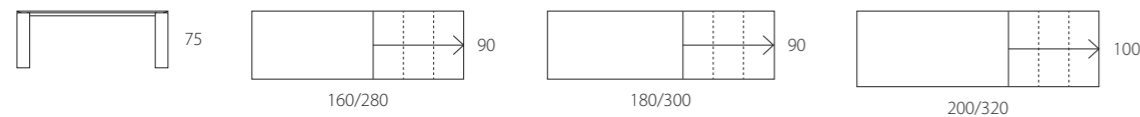

Tavolo allungabile in legno con gambe a cavalletto e piano e allunghe con bordi bisellati sp. 30 mm in rovere nodato miele, rovere poro aperto tinto bianco, naturale, miele, noce, tabacco, wengè, grigio, cenere, ciliegio o coke. Meccanismo di estensione in alluminio anodizzato. Allunghe alloggiato all'interno.

EN - Extending wooden table with trestle legs and 30mm thick top and extensions with bevelled edges, in miele knotted oak, open pore oak stained walnut, white, natural, honey, tobacco, wengè, grey, ash, cherrywood or coke. Anodised aluminium extending mechanism. Extensions housed inside the table.

FR - Table avec rallonges en bois avec pieds à chevalets et plan avec bords biseautés ép. 30 mm en chêne rouvre noyer, blanc, naturel, miele, tabac, wengè, gris, cendre cerisier ou coke. Mécanisme de extension en aluminium anodisé. Rallonges à l'intérieur.

DE - Ausziehbarer Tisch aus Holz mit Bockbeinen, Tischplatte und Verlängerungen mit schrägen Kanten St. 30 mm aus Eiche mit Astknoten in Honig, aus Eiche offenporig in der Farbe Nussbaum, Weiß, Natur, Honig, Tabak, Wenge, Grau, Asche, Kirschbaum oder Coke. Ausziehmechanik aus eloxiertem Aluminium. Verlängerungen im Inneren verstaut.





CITY

TAVOLO IN LEGNO
WOODEN TABLE

Designed by Riflessi Lab

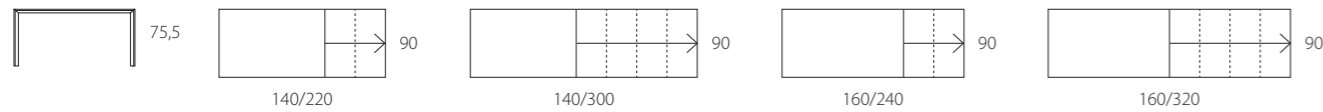

Tavolo allungabile con struttura e gambe in massello di frassino e piano in rovere poro aperto tinto bianco, naturale, miele, noce, tabacco, cenere, wengè, grigio, coke o ciliegio. Meccanismo di estensione in alluminio anodizzato o brunito. Sacca per allunghe esterne in dotazione.

EN - Extending table with solid ash wood structure and legs and top in open pore oak in the colours walnut, white, natural, honey, tobacco, wengè, grey, ash, cherrywood or coke. Anodised or burnished aluminium extending mechanism. Bag provided for external extensions.

FR - Table à rallonges avec structure et pied en frêne massif et plan en chêne rouvre pore ouvert couleur noyer, blanc, naturel, miele, tabac, wengè, gris, cendre, cerisier ou Coke. Mécanisme d'extension en aluminium anodisé ou bruni. Poche pour rallonges extérieures en dotation.

DE - Ausziehbarer Tisch mit Gestell und Beinen aus massiver Esche und Tischplatte aus Eiche offenporig in der Farbe Nussbaum, Weiß, Natur, Honig, Tabak, Wenge, Grau, Asche, Kirschbaum oder Coke. Ausziehmechanik aus eloxiertem Aluminium oder brüniert. Hülle für äußere Verlängerungen im Lieferumfang enthalten.





CLUB

TAVOLO IN LEGNO
WOODEN TABLE

Designed by Riflessi Lab

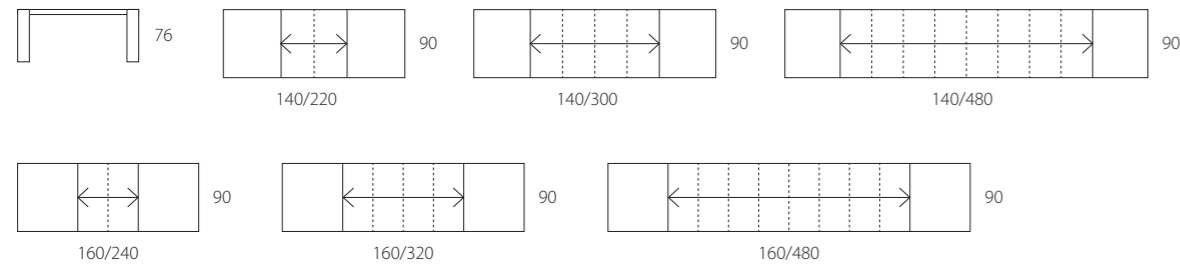

Tavolo allungabile in legno rovere poro aperto tinto bianco, wengè, naturale, miele, noce, tabacco, coke, cenere, grigio o ciliegio. Meccanismo brevettato per il posizionamento delle gambe centrali a scomparsa nelle dimensioni L 460 e L 480. Sacca per allunghe esterne in dotazione.

EN - Extending table in open pore oak in the colours walnut, white, natural, honey, tobacco, wengè, grey, ash or cherrywood. Patented mechanism for positioning the retractable central legs for sizes L 460 and L 480. Bag provided for external extensions.

FR - Table à rallonges en bois chêne rouvre couleur noyer, blanc, naturel, miele, tabac, wengè, gris, cendre ou cerisier. Mécanisme brevété pour le positionnement des pieds centraux escamotables dans les dimensions L 460 et L 480. Poche pour rallonges extérieures en dotation.

DE - Ausziehbarer Tisch aus Eiche offenporig in der Farbe Nussbaum, Weiß, Natur, Honig, Tabak, Wenge, Grau, Asche oder Kirschbaum. Patentierte Mechanik zum Aufstellen der mittleren versenkbaren Beine bei den Abmessungen B 460 und B 480. Hülle für äußere Verlängerungen im Lieferumfang enthalten.



TAVOLO ALLUNGABILE - EXTENDIBLE TABLE

LUXURY

TAVOLO IN LEGNO
WOODEN TABLE

Designed by Riflessi Lab

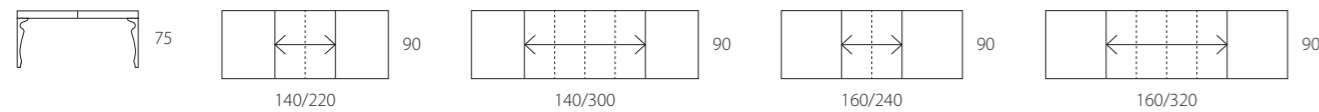

Tavolo allungabile con piano e allunghe interne in rovere poro aperto tinto bianco, wengè, naturale, miele, noce, tabacco, cenere, coke, grigio o ciliegio. Meccanismo di estensione in alluminio anodizzato. Gambe sagomate in acciaio cromato o verniciate ottone spazzolato a mano o colori RAL.

EN - Extending table with top and internal extensions in open pore oak in the colours walnut, white, natural, honey, tobacco, wengè, grey, ash or cherrywood. Anodised aluminium extending mechanism. Shaped legs in chrome-plated steel or painted hand brushed brass finish or RAL colours.

FR - Table à rallonges avec plan et rallonges internes en chêne rouvre pore ouvert couleur noyer, blanc, naturel, miel, tabac, wengè, gris, cendre ou cerisier. Mécanisme d'extension en aluminium anodisé. Pieds façonnés en acier chromé ou vernis laiton brossé à main ou couleurs RAL.

DE - Ausziehbarer Tisch mit Tischplatte und Verlängerungen im Inneren aus Eiche offenporig in der Farbe Nussbaum, Weiß, Natur, Honig, Tabak, Wenge, Grau, Asche oder Kirschbaum. Ausziehmechanik aus eloxiertem Aluminium. Geformte Beine aus verchromtem Stahl oder lackiert in handgebürstetem Messing oder in RAL-Farben.



TAVOLO ALLUNGABILE - EXTENDIBLE TABLE

ZED

TAVOLO IN LEGNO
WOODEN TABLE

Designed by Riflessi Lab

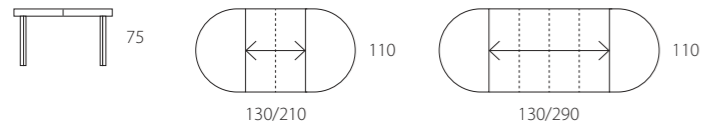

Tavolo oblungo allungabile in rovere poro aperto tinto bianco, grigio, tabacco, naturale, miele, noce, ciliegio, wengè o cenere. Meccanismo di estensione in alluminio brillantato.

EN - Oblong extending table in open pore oak in the colours walnut, white, natural, honey, tobacco, wengè, grey, ash or cherrywood. Polished aluminium extending mechanism.

FR - Table oblongue à rallonges en chêne rouvre pore ouvert couleur noyer, blanc, naturel, miele, tabac, wengè, gris, cendre ou cerisier. Mécanisme d'extension en aluminium poli.

DE - Ausziehbarer länglicher Tisch aus Eiche offenporig in der Farbe Nussbaum, Weiß, Natur, Honig, Tabak, Wenge, Grau, Asche oder Kirschbaum. Ausziehmechanik aus geglänztem Aluminium.





MANHATTAN

PIANO IN CRISTALLO O CERAMICA
GLASS OR CERAMIC TOP

Designed by Riflessi Lab

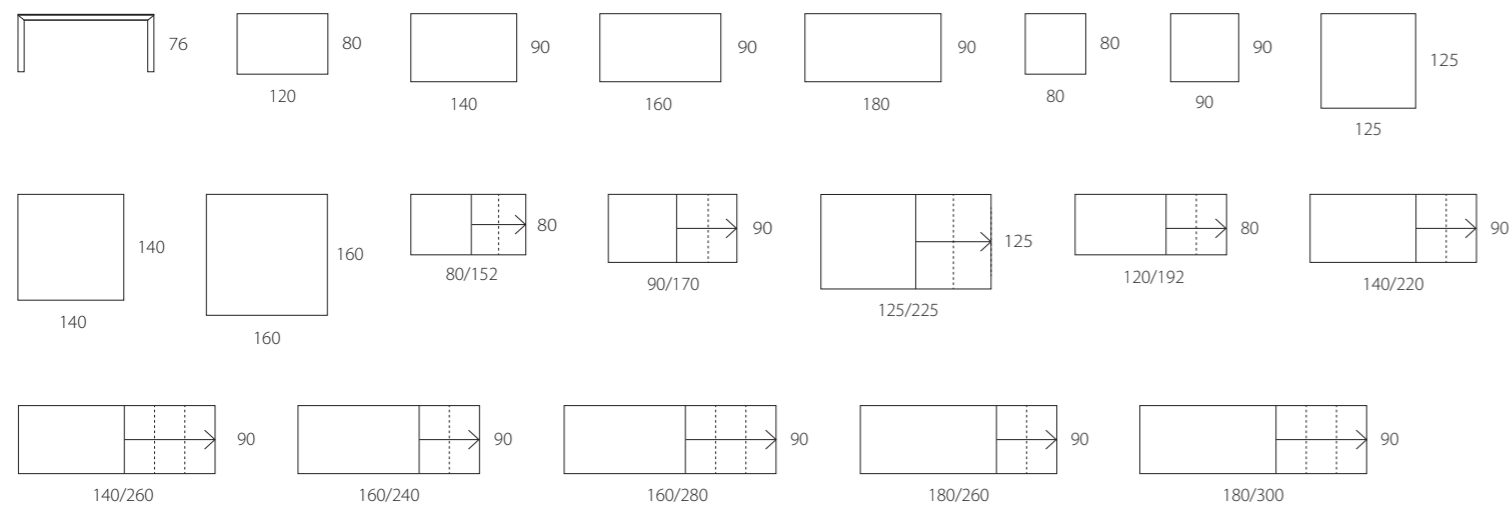

Sistema di tavoli fissi e allungabili con struttura e gambe in alluminio verniciato opaco bianco, tortora, grigio, antracite, ottone spazzolato a mano o colori Ral. Piano in cristallo temperato extrachiaro retroverniciato lucido o opaco negli stessi colori della struttura: bianco, tortora, grigio, antracite. Piano in ceramica bianco Statuario, pietra di Savoia antracite o grigio, Noir Desir lucido, Calacatta oro lucido.

EN - Series of fixed and extending tables with aluminium structure and legs in the colours matt white, dove-grey, grey, anthracite, hand brushed brass finish or RAL colours. Top in extra clear toughened glass back painted in the same matt or glossy colours as the structure: white, dove grey, grey or anthracite. Top in ceramic in Statuary white, Savoy stone grey, Savoy stone anthracite, glossy Noir Desir or glossy Calacatta gold.

FR - Système de tables fixes et à rallonges avec structure et pieds en aluminium verni mat blanc, taupe, gris, anthracite, laiton brossé à main ou couleurs RAL. Plan en verre trempé extra clair verni arrière brillant ou mat dans les mêmes couleurs de la structure: blanc, gris tourterelle, gris, anthracite. Plan en céramique bianco Statuario, pietra di Savoia antracite ou grigio, Noir Desir brillant, Calacatta oro brillant.

DE - System aus Tischen mit fester und ausziehbarer Tischplatte mit Gestell und Beinen aus matt lackiertem Aluminium in Weiß, Taubengrau, Grau, Anthrazit, handgebürstetem Messing oder RAL-Farben. Tischplatte aus gehärtetem extrahellem Kristall rückseitig lackiert in Hochglanz oder Matt in den Farben des Gestells: Weiß, Taubengrau, Grau, Anthrazit. Tischplatte aus Keramik in Bianco Statuario, Pietra Savoia Antracite oder Grigio, Noir Desir Hochglanz oder Calacatta Oro Hochglanz.







IL TAVOLO MANHATTAN, IN POCHE MOSSE
SI TRASFORMA DA QUADRATO A RETTANGOLARE

FROM SQUARE TO RECTANGULAR IN JUST A FEW MOVES



TOLEDO

PIANO IN CRISTALLO O CERAMICA
GLASS OR CERAMIC TOP

Designed by Riflessi Lab

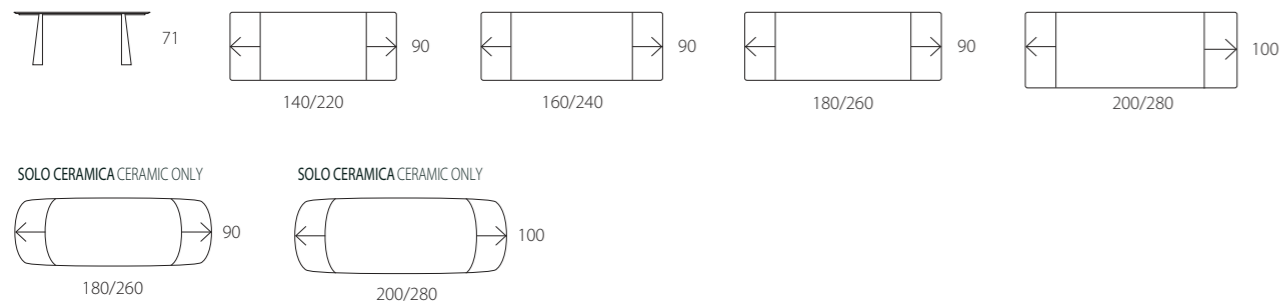

Tavolo allungabile con gambe in metallo pressopiegato verniciato grafite, bianco o ottone spazzolato a mano. Piano in cristallo trasparente temperato sp. 12 mm, extrachiaro o fumé. Guide in alluminio verniciato in tinta con la base. Piano in ceramica bisellata stratificata su vetro sp.12 mm bianco Statuario, pietra Savoia antracite o grigio, Noir Desir lucido o Calacatta oro lucido. Guide in alluminio verniciato in tinta con la base.

EN - Extending table with press-bent metal legs painted in the colours graphite, white or hand brushed brass finish. Top in 12mm thick transparent toughened glass, extra clear or fumé. Aluminium runners painted the same colour as the base. Top in bevelled ceramic layered onto 12mm thick glass in the colours in Statuary white, Savoy stone grey, Savoy stone anthracite, glossy Noir Desir or glossy Calacatta gold.

FR - Table à rallonges avec pieds en métal en métal plié verni graphite, blanc ou laiton brossé à main. Plan en verre transparent trempé ép.12 mm, extra clair ou fumé. Coulisses en aluminium verni dans la même couleur de la base. Plan en céramique biseauté stratifié sur verre ép.12 mm en blanc Statuaire, pierre Savoie Gris, pierre Savoie anthracite, Noir Desir brillant ou Calacatta or brillant.

DE - Ausziehbarer Tisch mit Beinen aus gebogenem lackiertem Metall in Graphitgrau, Weiß oder handgebürstetem Messing. Tischplatte aus gehärtetem transparentem Kristall St. 12 mm extrahell oder Fumè. Führungen aus lackiertem Aluminium in der Farbe des Gestells. Tischplatte aus Schichtkeramik auf Glas Stärke 12 mm in Weiß Statuario, Stein Savoyen Grau, Stein Savoyen Anthrazit, Noir Desir Hochglanz oder Calacatta Gold Hochglanz.





TAVOLO ALLUNGABILE - EXTENDIBLE TABLE

NEW PLANO

TAVOLO IN CRISTALLO
GLASS TABLE

Designed by Riflessi Lab

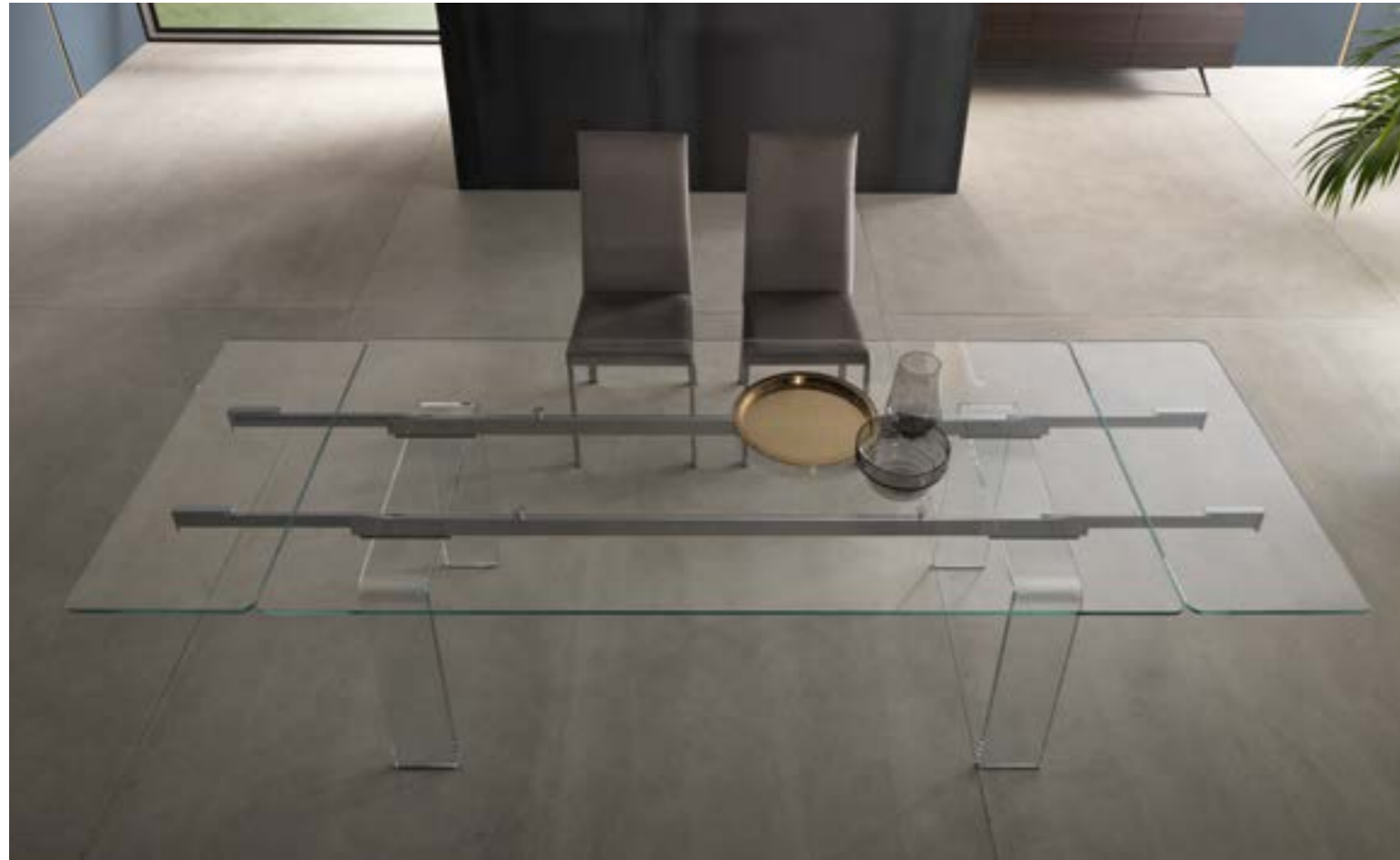

NEW PLANO

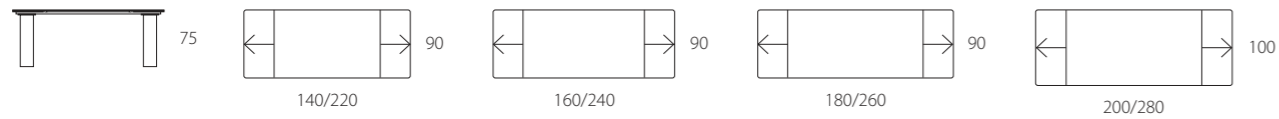

Tavolo allungabile con piano e gambe in cristallo temperato trasparente o trasparente extrachiaro. Meccanismi di estensione in alluminio brillantato disponibili anche in laccato lucido o opaco nei colori RAL.

EN - Extending table with transparent toughened glass or transparent extra clear glass top and legs. Polished aluminium extending mechanism also available glossy or matt lacquered in RAL colours.

FR - Table à rallonges avec plan et pieds en verre trempé transparent ou transparent extra clair. Mécanismes d'extension en aluminium poli disponibles aussi en laqué brillant ou mat en couleurs RAL.

DE - Ausziehbarer Tisch mit Tischplatte und Beinen aus gehärtetem transparentem oder extrahellem transparentem Kristall. Ausziehmechaniken aus geglänztem Aluminium auch erhältlich in Lack Hochglanz oder Matt in den RAL-Farben.

TAVOLO ALLUNGABILE - EXTENDIBLE TABLE

LORD

TAVOLO IN CRISTALLO
GLASS TABLE

Designed by Riflessi Lab

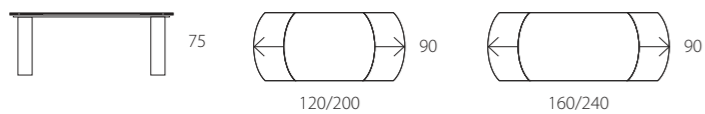

Tavolo allungabile con piano oblungo e gambe in cristallo temperato trasparente o trasparente extrachiario. Meccanismi di estensione in alluminio brillantato disponibili anche in laccato lucido o opaco nei colori RAL.

EN - Extending table with oblong top and transparent toughened glass or transparent extra clear glass legs. Polished aluminium extending mechanism also available glossy or matt lacquered in RAL colours.

FR - Table à rallonges avec plan oblongue et pieds en verre trempé transparent ou transparent extra clair. Mécanismes d'extension en aluminium poli disponibles aussi en laqué brillant ou mat en couleurs RAL.

DE - Ausziehbarer Tisch mit länglicher Tischplatte und Beinen aus gehärtetem transparentem oder extrahellem transparentem Kristall. Ausziehmechaniken aus geglänztem Aluminium erhältlich in Lack Hochglanz oder Matt in den RAL-Farben.



TAVOLO ALLUNGABILE - EXTENDIBLE TABLE

MITO/L e MITO/S

TAVOLO IN CRISTALLO E ACCIAIO
GLASS AND STEEL TABLE

Designed by Riflessi Lab

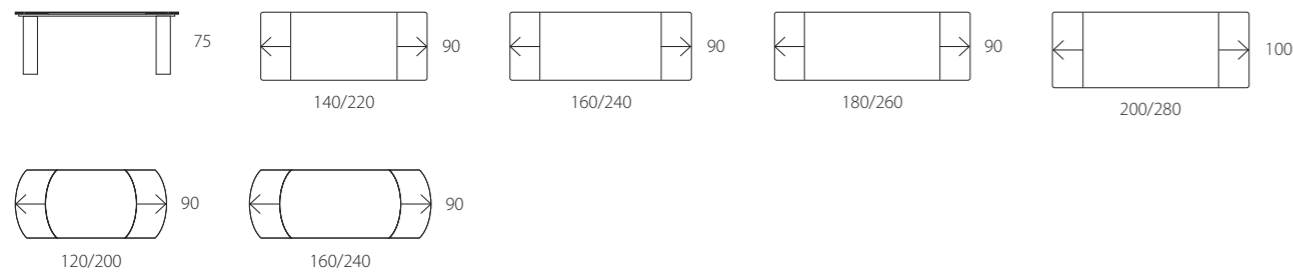

Tavolo allungabile con basi in acciaio specchiante o acciaio stropicciato. Piano in cristallo temperato trasparente o trasparente extrachiario sagomato o rettangolare. Meccanismi di estensione in alluminio brillantato disponibili anche in laccato lucido o opaco nei colori RAL.

EN - Extending table with mirror or crumpled effect steel. Shaped or rectangular top in transparent toughened or transparent extra clear glass. Polished aluminium extending mechanism also available glossy or matt lacquered in RAL colours.

FR - Table à rallonges avec bases en acier réfléchissant ou acier froissé. Plan en verre trempé transparent ou transparent extra clair façonné ou rectangulaire. Mécanismes d'extension en aluminium poli disponibles aussi en laqué brillant ou mat en couleurs RAL.

DE - Ausziehbarer Tisch mit Gestellen aus verspiegeltem Stahl oder Stahl in Knitteroptik. Geformt oder rechteckige Tischplatte aus gehärtetem transparentem oder extrahellem transparentem Kristall. Ausziehmechaniken aus geglänztem Aluminium auch erhältlich in Lack Hochglanz oder Matt in den RAL Farben.



CONSOLLE FISSE E ALLUNGABILI

FIXED AND EXTENDIBLE CONSOLES

PER FARE UN TAVOLO CI VUOLE
UNA CONSOLLE:
UN NUOVO CONCETTO
DI UTILIZZO DELLO SPAZIO

IT TAKES A CONSOLE TO MAKE A TABLE A NEW CONCEPT FOR ORGANISING SPACE

FUNZIONALI

FUNCTIONAL

Riflessi ha rivoluzionato il concetto di utilizzo dello spazio, che diventa flessibile e si trasforma in base alle esigenze del momento. Un punto di vista che non riguarda soltanto gli ambienti più piccoli che richiedono nel progetto d'arredo l'ottimizzazione degli spazi ma che coinvolge tutti coloro che desiderano un prodotto dalle alte prestazioni tecnologiche e funzionali.

EN - Riflessi has revolutionised the concept of using space, which becomes flexible and is transformed according to the needs of the moment. This does not refer only to small rooms where space must be optimised, but is also attractive to those seeking a technologically valid and functional product.

FR - Riflessi a révolutionné le concept d'utilisation de l'espace, qui devient flexible et se transforme selon les exigences du moment. Un point de vue qui ne concerne pas seulement les ambiances les plus petites qui requièrent l'optimisation des espaces dans leur projet d'ameublement, mais qui implique tous ceux qui désirent un produit aux prestations technologiques et fonctionnelles élevées.

DE - Riflessi hat das Raumnutzungskonzept revolutioniert, das Flexibilität erlangt und sich den aktuellen Anforderungen anpasst. Ein Aspekt, der nicht nur kleine Räume betrifft, bei deren Einrichtungsplanung der Raum optimiert werden muss, sondern der sich an alle richtet, die auf der Suche nach einem Produkt mit hohen technologischen und funktionalen Eigenschaften sind.

INNOVATIVE

INNOVATIVE

Le consolle allungabili sono il risultato di un percorso che ha portato l'azienda ad investire in tecnologia e innovazione. La caratteristica di questi apparentemente piccoli oggetti di arredo è che in pochi gesti si trasformano e da una modularità di circa 50 cm possono diventare tavoli che raggiungono dimensioni fino a 3 metri di lunghezza.

EN - Extending consoles are the result of the company's decision to invest in technology and innovation. The characteristic of these seemingly small items of furniture is that just a few moves and modularity of about 50cm can produce tables that reach up to 3 metres in length.

FR - Les consoles allongeables sont le résultat d'un parcours qui a amené l'entreprise à investir dans la technologie et l'innovation. La caractéristique de ces objets d'ameublement en apparence petits est qu'en quelques gestes, ils se transforment, et d'une modularité d'environ 50 cm, ils peuvent se transformer en tables qui atteignent des dimensions allant jusqu'à 3 mètres de long.

DE - Die ausziehbaren Konsolentischen sind das Resultat einer unternehmerischen Ausrichtung auf Investition in Technologie und Innovation. Das Merkmal dieser scheinbar kleinen Einrichtungsgegenstände liegt darin, dass sie mit nur wenigen Handgriffen von 50 cm großen modularen Elementen in bis zu 3 m lange Tische verwandelt werden können.

LIVING 152
FISSA - FIXED



SHANGAI 156
FISSA - FIXED



SHANGAI 160
ALLUNGABILE - EXTENDIBLE



PEGASO 162
FISSA - FIXED



CROSS 164
FISSA E ALLUNGABILE - FIXED AND EXTENDIBLE



SAPHIRIA 168
FISSA - FIXED



BRIDGE 172
FISSA - FIXED



MANHATTAN 174
FISSA E ALLUNGABILE - FIXED AND EXTENDIBLE



CITY 178
FISSA E ALLUNGABILE - FIXED AND EXTENDIBLE



PQR 180
FISSA E ALLUNGABILE - FIXED AND EXTENDIBLE



CORNER 184
FISSA E ALLUNGABILE - FIXED AND EXTENDIBLE



LUXURY 186
FISSA E ALLUNGABILE - FIXED AND EXTENDIBLE



LIVING

PIANO IN LEGNO, CERAMICA O CRISTALLO
WOODEN, CERAMIC OR GLASS TOP

Designed by Riflessi Lab



Consolle con base caratterizzata da due gambe inclinate e sovrapposte tra loro in maniera asimmetrica in metallo verniciato grafite o ottone spazzolato a mano o rivestito in pietra arenaria Rivergrey o Arabik. Piano con bordo irregolare sp. 50 mm in noce canaletto, rovere poro aperto tinto bianco, naturale, noce, miele, tabacco, wengè, grigio, cenere, coke o ciliegio. Piano in cristallo temperato extrachiaro sp. 12 mm. Piano in ceramica stratificata su vetro bisellato sp. 12 mm in bianco Statuario, pietra di Savoia antracite o grigio, Noir Desir lucido o Calacatta oro lucido.

EN - Console featuring a base with two inclined metal legs asymmetrically superimposed, painted in graphite or hand brushed brass finish, or covered in Rivergrey or Arabik sandstone. 50cm thick top with shaped edges, in American Walnut, open pore oak stained walnut, white, natural, honey, tobacco, wengè, grey, ash or cherrywood. Top in 12mm thick extra clear toughened glass. Top in ceramic layered onto 12mm thick bevelled glass in Statuary white, Savoy stone grey, Savoy stone anthracite, glossy Noir Desir or glossy Calacatta gold.

FR - Console avec base caractérisée par deux pieds inclinés et superposés entre eux en manière asymétrique en métal verni graphite ou laiton brossé à main ou revêtu en grès Arabik ou Rivergrey. Plan avec bord façonné ép. 50 mm en noyer, blanc, naturel, miel, tabac, wengè, gris, cendre ou cerisier. Plan en trempé extra clair ép. 12. Plan en céramique stratifié sur verre biseauté ép. 12 mm en blanc Statuario, Savoia antracite ou grigio stone, Noir Desir brillant ou Calacatta oro brillant.

DE - Konsolentisch mit Gestell aus zwei schrägen und asymmetrisch übereinander liegenden Beinen aus lackiertem Metall in Graphitgrau, handgebürstetem Messing oder beschichtet mit Sandstein Rivergrey oder Arabik. Tischplatte mit geformter Kante St. 50 mm aus amerikanischem Nussbaum, Eiche offenporig in der Farbe Nussbaum, Weiß, Natur, Honig, Tabak, Wenge, Grau, Asche oder Kirschbaum. Tischplatte aus gehärtetem extrahellem Kristall St. 12 mm. Tischplatte aus Schichtkeramik auf Glas mit schrägen Kanten St. 12 mm in Weiß Statuario, Stein Savoyen Grau, Stein Savoyen Anthrazit, Noir Desir Hochglanz oder Calacatta Gold Hochglanz.





SHANGAI

PIANO IN LEGNO, CERAMICA O CRISTALLO
WOODEN, CERAMIC OR GLASS TOP

Designed by Riflessi Lab



Consolle con base caratterizzata da due gambe inclinate e sovrapposte tra loro in maniera asimmetrica in alluminio verniciato, bianco, grafite, oro rosa o ottone spazzolato a mano o rivestito in acciaio inox specchiante. Piano con bordo irregolare sp. 50 mm in noce canaletto, rovere poro aperto tinto bianco, naturale, noce, miele, tabacco, wengè, grigio, cenere, coke o ciliegio. Piano in cristallo temperato extrachiaro sp. 12 mm. Piano in ceramica stratificata su vetro bisellato sp. 12 mm in bianco Statuario, pietra di Savoia antracite o grigio, Noir Desir lucido o Calacatta oro lucido.

EN - Console featuring a base with two aluminium legs asymmetrically superimposed, painted in the colours white, graphite, pink gold or hand brushed brass finish or covered in mirror-finish stainless steel. 50 mm thick top with shaped edges, in American walnut, open pore oak in the colours walnut, white, natural, honey, tobacco, wengè, grey, ash or cherrywood. Top in 12mm thick extra clear toughened glass. Top in ceramic layered onto 12mm thick bevelled glass in Statuary white, Savoy stone grey, Savoy stone anthracite, glossy Noir Desir or glossy Calacatta gold.

FR - Console avec base caractérisée par deux pieds inclinés et superposés entre eux en manière asymétrique en aluminium verni, blanc, graphite, or rose ou laiton brossé à main ou revêtu en acier inox réfléchissant. Plan avec bord façonné ép. 50 mm en noyer canaletto, chêne rouvre pore ouvert couleur noyer, blanc, naturel, miel, tabac, wengè, gris, cendre ou cerisier. Plan en verre trempé extra clair ép. 12. Plan en céramique stratifié sur verre biseauté ép. 12 mm en blanc Statuaire, pierre Savoie Gris, pierre Savoie anthracite, Noir Desir brillant ou Calacatta or brillant.

DE - Konsolentisch mit Gestell aus zwei schrägen und asymmetrisch übereinander liegenden Beinen aus lackiertem Aluminium in Weiss, Graphitgrau, Rosegold, handgebürstetem Messing oder beschichtet mit verspiegeltem Edelstahl. Tischplatte mit geformter Kante St. 50 mm aus amerikanischem Nussbaum, Eiche offenporig in der Farbe Nussbaum, Weiß, Natur, Honig, Tabak, Wenge, Grau, Asche oder Kirschbaum. Tischplatte aus gehärtetem extrahellem Kristall St. 12 mm. Tischplatte aus Schichtkeramik auf Glas mit schrägen Kanten St. 12 mm in Weiß Statuario, Stein Savoyen Grau, Stein Savoyen Anthrazit, Noir Desir Hochglanz oder Calacatta Gold Hochglanz.





CONSOLLE ALLUNGABILE - EXTENDIBLE CONSOLE

SHANGAI

PIANO IN LEGNO
WOODEN TOP

Designed by Riflessi Lab

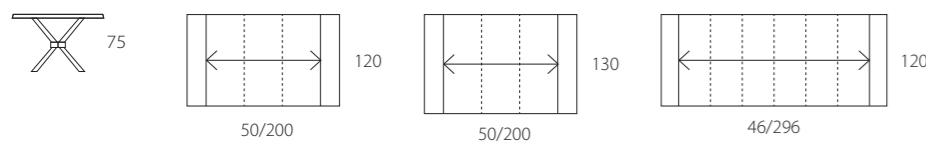

Consolle allungabile con base in alluminio verniciato grafite, bianco, oro rosa. Piano con bordo irregolare sp. 60 mm in rovere poro aperto tinto noce, bianco, naturale, miele, tabacco, wengè, grigio, cenere, ciliegio o colori RAL. Allunghe in tinta. Sacca per allunghe in dotazione.

EN - Extending console with aluminium base painted in the colours white, graphite, pink gold. 60 mm thick top with shaped edges in open pore oak in the colours walnut, white, natural, honey, tobacco, wengè, grey, ash, cherrywood or RAL colours. Extensions in the same colours. Bag provided for extensions.

FR - Consolle à rallonges avec base en aluminium verni blanc, graphite, or rose. Plan avec bord façonné ép. 60 mm en chêne rouvre pore ouvert couleur noyer, blanc, naturel, miele, tabac, wengè, gris, cendre, cerisier ou couleurs RAL. Rallonges dans la même couleur. Poche pour rallonges en dotation.

DE - Ausziehbarer Konsolentisch mit Gestell aus lackiertem Aluminium in Weiss, Graphitgrau, Rosegold. Tischplatte mit geformter Kante St. 60 mm aus Eiche offenporig in der Farbe Nussbaum, Weiß, Natur, Honig, Tabak, Wenge, Grau, Asche, Kirschbaum oder in den RAL-Farben. Verlängerungen in der gleichen Farbe. Hülle für Verlängerungen im Lieferumfang enthalten.



SHANGAI

PEGASO

PIANO IN LEGNO, CERAMICA O CRISTALLO

WOODEN, CERAMIC OR GLASS TOP

Designed by Riflessi Lab

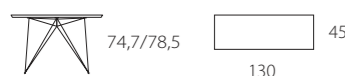

Consolle con base in alluminio verniciato grafite, bianco, oro rosa. Piano con bordo irregolare sp. 50 mm in noce canaletto, rovere poro aperto tinto bianco, naturale, noce, miele, tabacco, wengè, grigio, cenere, coke o ciliegio. Piano in cristallo temperato extrachiaro sp. 12 mm. Piano in ceramica stratificata su vetro bisellato sp. 12 mm in bianco Statuario, pietra di Savoia antracite o grigio, Noir Desir lucido o Calacatta oro lucido.

EN - Console with aluminium base painted in the colours white, graphite, pink gold. 50 mm thick top with shaped edges, in American walnut, open pore oak in the colours walnut, white, natural, honey, tobacco, wengè, grey, ash or cherrywood. Top in 12mm thick extra clear toughened glass. Top in ceramic layered onto 12mm thick bevelled glass in Statuary white, Savoy stone grey, Savoy stone anthracite, glossy Noir Desir or glossy Calacatta gold.

FR - Console avec base en aluminium verni blanc, graphite, or rose. Plan avec bord façonné ép. 50 mm en noyer canaletto, chêne rouvre pore ouvert couleur noyer, blanc, naturel, miele, tabac, wengè, gris, cendre ou cerisesier. Plan en verre trempé extra clair ép. 12. Plan en céramique stratifié sur verre biseauté ép. 12 mm en blanc Statuaire, pierre Savoie Gris, pierre Savoie anthracite, Noir Desir brillant ou Calacatta or brillant.

DE - Konsolentisch mit Gestell aus lackiertem Aluminium in Weiss, Graphitgrau, Rosegold. Tischplatte mit geformter Kante St. 50 mm aus amerikanischem Nussbaum, Eiche offenporig in der Farbe Nussbaum, Weiß, Natur, Honig, Tabak, Wenge, Grau, Asche oder Kirschbaum. Tischplatte aus gehärtetem extrahellem Kristall St. 12 mm. Tischplatte aus Schichtkeramik auf Glas mit schrägen Kanten St. 12 mm in Weiß Statuario, Stein Savoyen Grau, Stein Savoyen Anthrazit, Noir Desir Hochglanz oder Calacatta Gold Hochglanz.



CROSS

PIANO IN CERAMICA
CERAMIC TOP

Designed by Riflessi Lab

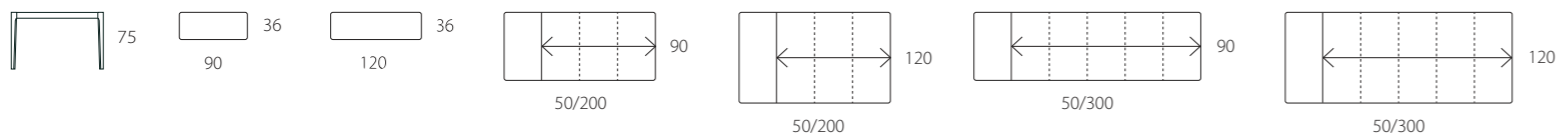

Consolle fissa e allungabile con struttura in legno frassino poro aperto tinto noce, coke termotrattato, bianco o miele. Piano in ceramica bianco Statuario, pietra Savoia grigio o antracite, Noir Desir lucido o Calacatta oro lucido. Allunghe in legno laccato opaco bianco o antracite

FR - Fixed or extending console with structure in walnut stained open pore ash wood, thermo-treated coke, white or honey oak. Ceramic top in Statuary white, Savoy stone grey, Savoy stone anthracite, Noir Desir or glossy Calacatta gold. Wooden extensions matt lacquered white or anthracite.

FR - Consolle fixes et à rallonges avec structure en bois frêne pore ouvert couleur noyer, coke thermo-traité, blanc ou miele. Plan en céramique blanc Statuaire, pierre Savoie Gris, pierre Savoie anthracite, Noir Desir brillant ou Calacatta or brillant. Rallonges en bois laqué mat blanc ou anthracite.

DE - Konsolentisch mit fester und ausziehbare Tischplatte und Gestell aus Esche offenporig in der Farbe Nussbaum, Coke wärmebehandelt, Weiß oder Miele. Tischplatte aus Keramik in Weiß Statuario, Stein Savoyen Grau, Stein Savoyen Anthrazit, Noir Desir Hochglanz oder Calacatta Gold Hochglanz. Verlängerungen aus matt lackiertem Holz Weiß oder Anthrazit.





CONSOLLE FISSA - FIXED CONSOLE

SAPHIRIA

CONSOLLE IN CRISTALLO

GLASS CONSOLE

Designed by Riflessi Lab

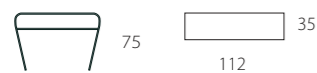

Consolle in cristallo curvato trasparente o fumé. Ripiano in cristallo trasparente o fumé o in ceramica Noir Desir lucido o Calacatta oro lucido.

FR - Console in curved transparent or fumé glass. Shelf in transparent or fumé glass or glossy Noir Desir or glossy Calacatta gold ceramic.

FR - Console en verre courbé transparent ou fumé. Etagère en verre transparent ou fumé ou en céramique Noir Desir brillant ou Calacatta oro brillant.

DE - Konsolentisch aus gebogenem transparentem Kristall oder Fumè. Fachboden aus Kristall oder Rauchglas oder aus Keramik Noir Desir Hochglanz oder Calacatta Oro Hochglanz.

SAPHIRIA





BRIDGE

CONSOLLE IN LEGNO
WOODEN CONSOLE

Designed by Riflessi Lab



Consolle fissa in legno rovere poro aperto tinto bianco, wengé, grigio, tabacco, naturale, coke, cenere, miele, noce, ciliegio o colori RAL. Disponibile anche rivestita in foglia oro, argento, rame, oro bianco, oro nero o bronzo.

FR - Fixed console in open pore oak in the colours white, wengé, grey, tabacco, natural, coke, ash, honey, walnut, cherrywood or RAL colours. Also available covered in gold, silver, copper, white gold, black gold or bronze leaf.

FR - Console fixe en bois chêne rouvre pore ouvert couleur blanc, wengé, gris, tabac, naturel, coke, cendre, miele, noyer, cerisier ou couleurs RAL. Disponible aussi revêtu en feuille or, argent, cuivre, or blanc, or noir ou bronze..

DE - Konsolentisch mit fester Tischplatte aus Eiche offenporig in der Farbe Weiß, Grau, Tabak, Natur, Coke, Asche, Honig, Nussbaum, Kirschbaum oder in den RAL Farben. Auch erhältlich mit Folienbeschichtung in Gold, Silber, Kupfer, Weißgold, Schwarzgold oder Bronze.



MANHATTAN

PIANO IN CRISTALLO O CERAMICA
GLASS OR CERAMIC TOP

Designed by Riflessi Lab

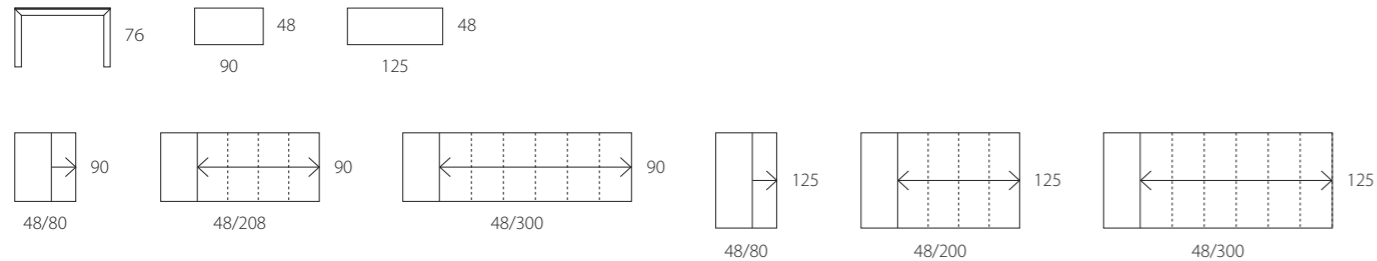

Sistema di consolle fisse e allungabili con struttura e gambe in alluminio verniciato opaco bianco, tortora, grigio, antracite; ottone spazzolato a mano o nei colori RAL. Piano in cristallo temperato extrachiario retroverniciato lucido o opaco nei colori bianco, tortora, grigio, antracite. Piano in ceramica bianco Statuario, pietra di Savoia antracite o grigio, Noir Desir lucido, Calacatta oro lucido. Meccanismo di estensione in alluminio anodizzato color champagne. Esclusivo meccanismo brevettato per il funzionamento delle gambe centrali a scomparsa (solo per versione allungabile L 3 mt.) Allunghe in legno laccato opaco in tinta. Sacca per allunghe esterne in dotazione.

EN - Fixed or extending console system with aluminium structure and legs, painted in the colours matt white, dove-grey, grey, anthracite; hand brushed brass finish or RAL colours. Top in extra clear toughened glass, back painted in matt or glossy glossy white, dove grey, or anthracite. Ceramic top in Statuary white, Savoy stone grey, Savoy stone anthracite, glossy Noir Desir or glossy Calacatta gold. Champagne coloured anodised aluminium extending mechanism. Exclusive patented mechanism for the retractable centre leg (for L 3m extending versions only). Extensions in wood matt lacquered in the same colour. Bag provided for external extensions.

FR - Système de tables fixes et à rallonges avec structure et pieds en aluminium verni mat blanc, ris tourterelle, gris, anthracite; laiton brossé à main ou couleurs RAL. Plan en verre trempé extra clair verni arrière brillant ou mat dans les mêmes couleurs de la structure: bianco, tortora, grigio, antracite. Plan en blanc Statuaire, pierre Savoie Gris, pierre Savoie anthracite, Noir Desir brillant ou Calacatta or brillant. Mécanisme d'extraction en aluminium anodisé color champagne. Mécanisme exclusive breveté pour le fonctionnement des pieds centraux escamotables (seulement pour version à rallonge L 3 mt.) Rallonges en bois laqué mat en teint. Poche pour rallonges extérieures en dotation.

DE - System aus Konsolentischen mit fester und ausziehbarer Tischplatte mit Gestell und Beinen aus matt lackiertem Aluminium in Weiß, Taubengrau, Grau, Anthrazit, handgebürstetem Messing oder in den RAL-Farben. Tischplatte aus gehärtetem extrahellem Kristall rückseitig lackiert in Hochglanz oder Matt in den Farben Weiß, Taubengrau, Grau, Anthrazit. Tischplatte aus Keramik in Weiß Statuario, Stein Savoyen Grau, Stein Savoyen Anthrazit, Noir Desir Hochglanz oder Calacatta Gold Hochglanz. Ausziehmechanik aus eloxiertem Aluminium in der Farbe Champagner. Exklusive patentierte Mechanik zum Aufstellen der mittleren versenkbaren Beine (nur für das ausziehbare Modell L 3 m) Verlängerungen aus matt lackiertem Holz in der gleichen Farbe. Hülle für äußere Verlängerungen im Lieferumfang enthalten.





CITY

CONSOLLE IN LEGNO
WOODEN CONSOLE

Designed by Riflessi Lab

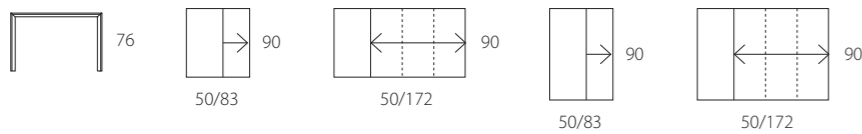

Consolle allungabile con struttura e gambe in massello di frassino e piano in rovere poro aperto tinto bianco, naturale, miele, noce, tabacco, wengè, grigio, ciliegio o cenere. Meccanismo di estensione in alluminio anodizzato o brunito. Sacca per allunghe esterne in dotazione.

EN - Extending console with solid ash wood structure and legs and top in open pore oak in the colours walnut, white, natural, honey, tobacco, wengè, grey, ash or cherrywood. Anodised or burnished aluminium extending mechanism. Bag provided for external extensions.

FR - Console à rallonges avec structure et pieds en frêne massif et plan en chêne rouvre pore ouvert couleur noyer, blanc, naturel, miele, tabac, wengè, gris, cendre ou cerisier. Mécanisme d'extension en aluminium anodisé ou bruni. Poche pour rallonges extérieures en dotation.

DE - Ausziehbarer Konsolentisch mit Gestell und Beinen aus massiver Esche und Tischplatte aus Eiche offenporig in der Farbe Nussbaum, Weiß, Natur, Honig, Tabak, Wenge, Grau, Asche oder Kirschbaum. Ausziehmechanik aus eloxiertem Aluminium oder brüniert. Hülle für äußere Verlängerungen im Lieferumfang enthalten.



P-Q-R

CONSOLLE IN LEGNO
WOODEN CONSOLE

Designed by Riflessi Lab

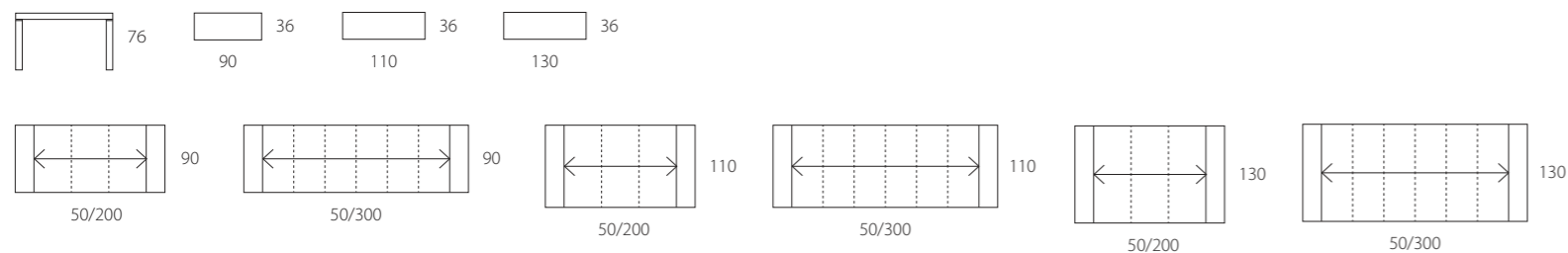

Consolle fissa o allungabile in legno laccato bianco opaco o rovere poro aperto tinto bianco, rovere coke, rovere nodato miele, ciliegio, grigio, tabacco, wengè, naturale, noce, miele, cenere o noce canaletto. Meccanismo di estensione in alluminio anodizzato color champagne. Esclusivo meccanismo brevettato per il funzionamento delle gambe centrali a scomparsa (solo per la versione a 3 m). Allunghe in legno in tinta. Sacca per allunghe esterne in dotazione.

EN - Fixed or extending console in bianco matt lacquered wood or stained open pore oak, coke oak, or knotted oak in the colours honey, cherrywood, grey, tobacco, wengè, natural, walnut, honey, ash or American Walnut. Champagne coloured anodized aluminium extending mechanism. Exclusive patented mechanism for the retractable centre leg (for the L 3m version only). Wooden extensions in the same colour. Bag provided for external extensions.

FR - Consolle à rallonges en bois laqué blanc mat ou chêne rouvre pore ouvert couleur blanc, rovere coke, rovere nouveaux miel, cerisier, gris, tabac, wengè, naturel, noyer, miele, cendre ou noyer Canaletto. Mécanisme d'extension en aluminium anodisé color champagne. Mécanisme exclusive breveté pour le fonctionnement des pieds centraux escamotables (seulement pour version à rallonge L 3 mt.) Rallonges en bois laqué mat en teint. Poche pour rallonges extérieures en dotation.

DE - Konsolentisch mit fester oder ausziehbarer Tischplatte aus matt lackiertem Holz in Weiß oder aus Eiche offenporig in der Farbe Weiß, Eiche Coke, Eiche mit Astknoten in Honig, Kirschbaum, Grau, Tabak, Wenge, Natur, Nussbaum, Honig, Asche oder amerikanischem Nussbaum. Ausziehmechanik aus eloxiertem Aluminium in der Farbe Champagner. Exklusive patentierte Mechanik zum Aufstellen der mittleren versenkbaren Beine (nur für das ausziehbare Modell L 3 m) Verlängerungen aus Holz in der gleichen Farbe. Hülle für äußere Verlängerungen im Lieferumfang enthalten.





Pochi gesti permettono una trasformazione quasi impensabile: la modularità di estensione consente ad una piccola consolle di 50 cm di diventare un tavolo che raggiunge la lunghezza massima di 3 m. Con il nuovo sistema di apertura estensibile telescopico, le gambe centrali della consolle sono a scomparsa e posizionate all'interno del piano, in modo da evitare l'ingombro quando ci si siede ai lati centrali del tavolo.

EN - Just a few moves create an almost unthinkable transformation: extending modularity makes a 50cm console into a table that can reach a length of 3 m. Our new telescopic, extending opening system means that the console's centre legs are retractable inside the top, so that they do not disturb whoever sits at the central sides of the table.

FR - Quelques gestes permettent une transformation presque impensable : la modularité d'extension permet à une petite console de 50 cm de devenir une table qui atteint une longueur maximum de 3 m. Avec le nouveau système d'ouverture extensible télescopique, les piètements centraux de la consolle sont invisibles et positionnés à l'intérieur du plateau, de façon à éviter l'encombrement lorsque l'on s'assied sur les côtés centraux de la table.

DE - Nur wenige Handgriffe für eine fast undenkbbare Verwandlung: durch den modularen Aufbau der Verlängerung wird ein kleiner Konsolentisch von nur 50 cm zu einem maximal 3 m langen Tisch. Beim neuen Teleskopauszugssystem sind die mittleren Beine des Konsolentischs im Inneren der Tischplatte versenkt, damit sie beim Sitzen an der mittleren Seite des Tischs nicht stören.

CONSOLLE ALLUNGABILE - EXTENDIBLE CONSOLE

CORNER

PIANO IN CRISTALLO O CERAMICA
GLASS OR CERAMIC TOP

Designed by Riflessi Lab

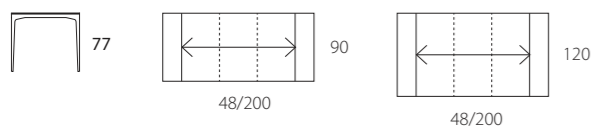

Consolle allungabile con struttura in metallo laccato opaco bianco e piano cristallo bianco o ceramica bianco Statuario. Struttura ottone spazzolato a mano con piano in ceramica Noir Desir lucido o Calacatta oro lucido. Meccanismo di estensione in alluminio anodizzato. Allunghe in legno laccato opaco in tinta col piano. Sacca per allunghe in dotazione.

EN - Extending console with matt bianco lacquered metal and top in bianco glass or white Statuary ceramic. Structure in hand brushed brass finish with glossy Noir Desir or glossy Calacatta gold ceramic. Anodised aluminium extending mechanism. Extensions in matt lacquered wood in the same colour as the top. Bag provided for extensions.

FR - Console à rallonges avec structure en métal laqué mat bianco et plan en verre blanc ou céramique blanc Statuaire. Structure en laiton brossé à main avec plan en céramique Noir Desir brillant ou Calacatta oro brillant. Mécanisme d'extraction en aluminium anodisé. Rallonges en bois laqué mat dans la même couleur du plan. Poche pour rallonges en dotation.

DE - Ausziehbarer Konsolentisch mit Gestell aus matt lackiertem Metall in Weiß und Tischplatte aus weißem Kristall oder Keramik in Bianco Statuario. Gestell aus handgebürstetem Messing mit Tischplatte aus Keramik in Noir Desir Hochglanz oder Calacatta Gold Hochglanz. Ausziehmechanik aus eloxiertem Aluminium. Verlängerungen aus matt lackiertem Holz in der Farbe der Tischplatte. Hülle für Verlängerungen im Lieferumfang enthalten.

CORNER



LUXURY

PIANO LEGNO - WOODEN TOP

Designed by Riflessi Lab

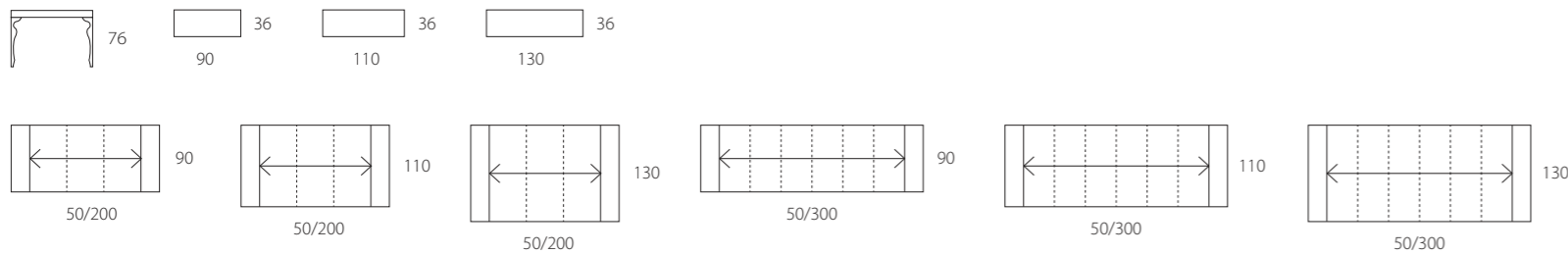

Consolle fissa o allungabile con piano in rovere poro aperto tinto bianco, wengè, naturale, miele, noce, tabacco, cenere, coke, grigio o ciliegio; laccato opaco bianco o coke termotrattato. Meccanismo di estensione in alluminio anodizzato. Gambe sagomate in acciaio cromato o verniciate ottone spazzolato a mano o laccate bianco.

EN - Fixed or extending console with open pore oak top in the colours walnut, white, natural, honey, tobacco, wengè, grey, ash, coke or cherrywood; white matt lacquered or thermo-treated coke oak. Anodised aluminium extending mechanism. Shaped legs in chrome-plated or painted steel, hand brushed brass finish or bianco lacquered.

FR - Consolle fixe ou à rallonges avec plan en chêne rouvre pore ouvert couleur noyer, blanc, naturel, miele, tabac, wengè, gris, cendre, coke ou cerisier; laqué mat blanc ou coke thermo-traité. Mécanisme d'extension en aluminium anodisé. Pieds façonnés en acier chromé ou laiton brossé à main.

DE - Konsolentisch mit fester oder ausziehbarer Tischplatte aus Eiche offenporig in der Farbe BNussbaum, Weiß, Natur, Honig, Tabak, Wenge, Grau, Asche, Coke oder Kirschbaum; Lack Matt in Weiß oder Coke wärmebehandelt. Ausziehmechanik aus eloxiertem Aluminium. Geformte Beine aus verchromtem Stahl oder lackiert in handgebürstetem Messing oder weiß lackiert.



LE SEDIE

CHAIRS

FLESSIBILITÀ E BELLEZZA PER IL TUO COMFORT

FLEXIBILITY AND BEAUTY FOR YOUR COMFORT
FLEXIBILITÉ ET BEAUTÉ POUR VOTRE CONFORT
FLEXIBILITÄT UND SCHÖNHEIT FÜR IHREN KOMFORT



IMBOTTITURE INDEFORMABILI RESISTENTI ALLE PRESSIONI E ALL'USURA.

EN - High density foam padding resistant to pressure and use.

FR - Rembourrages indéformables
Résistants aux pressions et à l'usure.

DE - Formstabile Polsterungen beständig gegen Druck und Abnutzung.

SCHIENALI FLESSIBILI PER AGEVOLARE L'APPOGGIO DELLA SCHIENA.

EN - Flexible backrests provides better back support.

FR - Dossiers flexibles pour faciliter le confort du dos.

DE - Flexible Rückenlehnen um den Rücken besser abzustützen.

FASCE ELASTICHE NELLE SEDUTE PER RENDERLE ESTREMAMENTE CONFORTEVOLI

EN - Elastic seat webbing for extreme comfort.

FR - Bandes élastiques dans les assises pour les rendre extrêmement confortables.

DE - Elastische Bänder in den Sitzflächen für extremen Komfort.

TESSUTI CERTIFICATI RESISTENTI, IGNIFUGHI E ANTIMACCHIA

EN - Certified fabric resistance, fire and stain proofing

FR - Tissus certifiés résistants, ignifuges et antitaches

DE - Zertifizierte widerstandsfähige, feuerhemmende und fleckbeständige Stoffe

MASSIMA PERSONALIZZAZIONE ATTRAVERSO L'ABBINAMENTO DEI RIVESTIMENTI CON I MATERIALI PER LE GAMBE

EN - Enhanced customisation by coordinating upholstery with the leg materials

FR - Personnalisation maximum à travers l'assemblage des revêtements avec les matériaux pour les pieds

DE - Maximale individuelle Gestaltung durch die Kombination der Bezüge mit den Materialien der Beine



RIFLESSI HA SELEZIONATO ACCURATAMENTE TUTTI I MIGLIORI MATERIALI PRODOTTI IN ITALIA PER LA REALIZZAZIONE E LA PERSONALIZZAZIONE DELLE PROPRIE SEDIE

RIFLESSI HAS CAREFULLY SELECTED ALL THE BEST MATERIALS MADE IN ITALY FOR
MANUFACTURING AND CUSTOMISING ITS CHAIRS

RIFLESSI A SELECTIONNE SOIGNEUSEMENT TOUS LES MEILLEURS MATERIAUX PRODUITS EN ITALIE
POUR LA REALISATION ET LA PERSONNALISATION DE SES CHAISES

RIFLESSI HAT FÜR DIE HERSTELLUNG UND INDIVIDUELLE GESTALTUNG SEINER STÜHLE NUR DIE
BESTEN IN ITALIEN PRODUZIERTEN MATERIALIEN SORGFÄLTIG AUSGEWÄHLT

RIVESTIMENTI UPHOLSTERY - REVETEMENTS - BEZÜGE



TESSUTI
FABRICS

PELLE
LEATHER

**URBAN
ECOPELLE**
ECO-LEATHER

**SAHARA
ECONABUK**

VELLUTO
VELVET

SMACCHIA
TESSUTO
FABRIC

MATERIALI PER LE GAMBE MATERIALS FOR LEGS - MATERIAUX POUR LES PIEDS - MATERIALIEN FÜR BEINE



CROMATE
CHROMED

LEGNO
WOOD

RIVESTITE
UPHOLSTERED

VERNICIATE
PAINTED

LE GAMBE SONO PERSONALIZZABILI CON TUTTE LE TINTE RAL

Legs can be customised with any of the Ral colours.
Les pieds sont personnalisables avec toutes les couleurs Ral.
Beine können mit alle Ral-farben personalisiert werden.



SOFIA 192



CARMEN 196



GIÒ 198



CHELSEA 200



VITTORIA flex 226



NINA flex 228



SONIA flex 230



SLIM flex 232



YORK 202



ANGY 204



BRIGITTE 206



CHERIE 208



LUNA flex 234



DENISE flex 236



ANNA 238



GAIA flex 239



MARGOT 210



AURORA 212



SVEVA flex 214



MAVI 216



EVA flex 240



SARA 241



LADY 242



VANESSA 243



PERLA 218



STELLA flex 220



BRUNA flex 222



MARTA flex 224



ALICE 244



LILIA 245



PIUMA 246



SEDIA - CHAIR

SOFIA

Design Stefano Sandonà e Sabrina Bettini



**GOOD
DESIGN
AWARD
2017**

OF CHICAGO
ATHENAEUM
MUSEUM OF
ARCHITECTURE
AND DESIGN

Sedia con struttura e gambe in metallo verniciato. Seduta e schienale ergonomici rivestiti. Imbottitura in poliuretano schiumato flessibile e ignifugo. Disponibile anche in versione sgabello.

EN - Chair with painted metal frame and legs. Upholstered ergonomic seat and backrest. Padding in flexible, fireproof polyurethane foam. Also available as a stool.

FR - Chaise avec structure et pieds en métal verni. Assise et dossier ergonomiques revêtus. Rembourrage en polyuréthane moussé flexible et ignifuge. Disponible aussi en version tabouret

DE - Stuhl mit Gestell und Beinen aus lackiertem Metall. Ergonomische Sitzfläche und Rückenlehne mit Bezug. Polsterung aus elastischem und feuerhemmendem Polyurethanschaum. Auch als Hocker erhältlich.



SOFIA



SEDIA - CHAIR

CARMEN

Design Stefano Sandonà e Sabrina Bettini



Poltroncina con braccioli in schiuma di poliuretano flessibile a freddo con telaio in acciaio, seduta con fasce elastiche e schienale flessibile. Struttura del telaio integrata nella scocca. Gambe verniciate, seduta e schienale rivestiti. Disponibile anche in versione sgabello.

EN - Armchair with flexible cold-foamed polyurethane armrests and steel frame, seat with elastic webbing and flexible backrest. Frame incorporated in the shell. Painted legs, seat and backrest upholstered. Also available as a stool.

FR - Fauteuil avec accoudoirs en mousse de polyuréthane flexible à froid avec cadre en acier, assise avec bandes élastiques et dossier flexible. Structure du cadre intégrée dans la coque. Pieds vernis, assise et dossier revêtus. Disponibles aussi en version tabouret.

DE - Sessel mit Armlehnen aus kalt elastischem Polyurethanschaum mit Gestell aus Stahl, Sitzfläche und flexible Rückenlehne. Gestell in die Sitzschale integriert. Beine lackiert, Sitzfläche und Rückenlehne mit Bezug. Auch als Hocker erhältlich.



SEDIA - CHAIR

GIÒ

Design Riflessi Lab



Sedia con scocca in tecnopolimero plastico, imbottita e rivestita. Gambe verniciate o in legno frassino tinto naturale, coke, noce e wengè. Disponibile anche in versione sgabello.

EN - Chair with padded, upholstered plastic technopolymer shell. Legs painted or in ash wood in the colours natural, coke, walnut and wengè. Also available as a stool.

FR - Chaise avec coque en tecnopolymère plastique, rembourrée et revêtue. Pleds vernis ou en bois frêne couleur naturel, coke, noyer et wengè. Disponible aussi en version tabouret

DE - Stuhl mit Sitzschale aus Kunststoff, gepolstert und mit Bezug. Beine lackiert oder aus Esche in der Farbe Natur, Coke, Nussbaum und Wenge. Auch als Hocker erhältlich.



GIÒ

CHELSEA

Design Riflessi Lab



Sedia con braccioli in schiuma di poliuretano flessibile a freddo con retro schienale e struttura in acciaio finitura oro o cromo. Seduta e schienale rivestiti.

EN - Armchair with flexible cold-foamed polyurethane armrests and gold or chrome finish steel for the rear backrest and shell. Upholstered seat and backrest.

FR - Chaise avec accoudoirs en mousse de polyuréthane flexible à froid avec arrière dossier et structure en acier finition or ou chrome. Assise et dossier revêtus.

DE - Stuhl mit Armlehnen aus kalt elastischem Polyurethanschaum mit rückseitiger Rückenlehne und Gestell aus Stahl in der Ausführung Gold oder Chrom. Sitzfläche und Rückenlehne mit Bezug.



POLTRONA - ARMCHAIR

YORK

Design Riflessi Lab



Poltrona con struttura in metallo verniciato con trattamento galvanico. Seduta e schienale ergonomici rivestiti. Imbottitura in poliuretano schiumato flessibile e ignifugo con cinghie elastiche in seduta. Base cromo, rame o ottone.

EN - Armchair with galvanised painted metal shell. Ergonomic, upholstered seat and backrest. Padded with flexible, fireproof polyurethane foam with elastic webbing for the seat. Chrome, copper or brass finish base.

FR - Fauteuil avec structure en métal verni avec traitement galvanisé. Assise et dossier ergonomiques revêtus. Rembourrage en polyuréthane moussé flexible et ignifuge avec bandes élastique en assise. Base chrome, cuivre et laiton.

DE - Sessel mit Gestell aus lackiertem Metall mit galvanischer Behandlung. Ergonomische Sitzfläche und Rückenlehne mit Bezug. Polsterung aus elastischem und feuerhemmendem Polyurethanschaum mit elastischen Riemen an der Sitzfläche. Gestell aus Chrom, Kupfer oder Messing.



YORK

SEDIA - CHAIR

ANGY

Design Riflessi Lab



Sedia rivestita con schienale alto o basso sagomato ed ergonomico. Gambe in legno frassino tinto naturale, noce, wengè e coke.

EN - Upholstered chair with ergonomic, high or low shaped backrest. Ash wood legs in the colours natural, walnut, wengè or coke.

FR - Chaise revêtue avec dossier haut ou bas façonné et ergonomique. Pieds en bois frêne couleur naturel, noyer, wengè et coke.

DE - Stuhl mit Bezug und hoher oder niedriger geformter und ergonomischer Rückenlehne. Beine aus Esche in der Farbe Natur, Nussbaum, Wenge und Coke.

ANGY



SEDIA - CHAIR

BRIGITTE

Design Riflessi Lab



Sedia con schienale alto o basso con seduta imbottita e telaio in acciaio. Gambe in legno frassino tinto naturale, noce, wengè e coke.

EN - Chair with high or low backrest, padded seat and steel frame. Ash wood legs in the colours natural, walnut, wengè or coke.

FR - Chaise avec dossier haut ou bas avec assise rembourré et cadre en acier. Pieds en bois frêne couleur naturel, noyer, wengè et coke.

DE - Stuhl mit hoher oder niedriger Rückenlehne, gepolsterter Sitzfläche und Gestell aus Stahl. Beine aus Esche in der Farbe Natur, Nussbaum, Wenge und Coke.



BRIGITTE

SEDIA - CHAIR

CHERIE

Design Riflessi Lab



Sedia con schienale alto o basso rivestita con applicazione di cuscino su seduta e schienale. Gambe in legno frassino tinto naturale, noce, wengè e coke.

EN - Upholstered chair with high or low, cushioned backrest and cushioned seat. Ash wood legs in the colours natural, walnut, wengè or coke.

FR - Chaise avec dossier haut ou bas revêtue avec application du coussin sur siège et dossier. Pieds en bois frêne couleur naturel, noyer, wengè et coke.

DE - Stuhl mit hoher oder niedriger Rückenlehne, mit applizierten Kissen auf Sitzfläche und Rückenlehne. Beine aus Esche in der Farbe Natur, Nussbaum, Wenge und Coke.

CHERIE



SEDIA - CHAIR

MARGOT

Design Riflessi Lab



Sedia con o senza braccioli con struttura in legno frassino tinto naturale, noce, wengè e coke. Seduta con fase elastiche e schienale ergonomici rivestiti. Imbottitura alta densità.

EN - Chair with or without armrests in ash wood in the colours natural, walnut, wengè or coke. Ergonomic, upholstered seat with elastic webbing and upholstered backrest. High-density padding.

FR - Chaise avec ou sans accoudoirs avec structure en bois frêne couleur naturel, noyer, wengè et coke. Assise avec bandes élastiques et dossier ergonomiques revêtus. Rembourrage à haute densité.

DE - Stuhl mit oder ohne Armlehnen und Gestell aus Esche in der Farbe Natur, Nussbaum, Wenge und Coke. Ergonomische Sitzfläche mit elastischen Bändern und Rückenlehne mit Bezug. Hoch verdichtete Polsterung.



MARGOT

SEDIA - CHAIR

AURORA

Design Riflessi Lab



Sedia con seduta imbottita e struttura in acciaio. Seduta e schienale rivestiti. Gambe verniciate o rivestite. Disponibile con schienale alto o basso con e senza braccioli.

EN - Chair with steel frame and padded seat. Upholstered seat and backrest. Painted or upholstered legs. Available with high or low backrest, with or without armrests.

FR - Chaise avec assise rembourrée et structure en acier. Assise et dossier revêtus. Pieds vernis ou revêtus. Disponible avec dossier haut ou bas avec ou sans accoudoirs.

DE - Stuhl mit gepolsterter Sitzfläche und Gestell aus Stahl. Sitzfläche und Rückenlehne mit Bezug. Beine lackiert oder beschichtet. Erhältlich mit hoher oder niedriger Rückenlehne mit und ohne Armlehnen.

AURORA



SEDIA - CHAIR

SVEVA flex

Design Riflessi Lab



Sedia interamente rivestita con struttura in acciaio e cuscino imbottito su seduta e schienale. Schienale flessibile disponibile alto o basso.

EN - Upholstered chair with steel frame and padded cushion on seat and backrest. Available with high or low, flexible backrest.

FR - Chaise entièrement revêtue avec structure en acier et coussin rembourré sur siège et dossier. Dossier flexible disponible haut ou bas.

DE - Komplett bezogener Stuhl mit Gestell aus Stahl und gepolsterter Kissen auf Sitzfläche und Rückenlehne. Flexible Rückenlehne hoch oder niedrig erhältlich.



SEDIA - CHAIR

MAVI

Design Riflessi Lab



Sedia con struttura in acciaio rivestita con applicazione di cuscino su seduta e schienale. Gambe verniciate o rivestite. Disponibile con schienale alto o basso con e senza braccioli.

EN - Upholstered chair with steel frame and cushioned backrest and seat. Painted or upholstered legs. Available with high or low backrest, with or without armrests.

FR - Chaise avec structure en acier revêtue avec application de coussin sur assise et dossier. Pieds vernis ou revêtus. Disponible avec dossier haut ou bas avec ou sans accoudoirs.

DE - Stuhl mit Gestell aus Stahl und applizierten Kissen auf Sitzfläche und Rückenlehne. Beine lackiert oder beschichtet. Erhältlich mit hoher oder niedriger Rückenlehne mit und ohne Armlehnen.

MAVI

UN CUSCINO AVVOLGE SEDUTA E SCHIENALE ASSICURANDO MORBIDEZZA E COMODITÀ

THE CUSHION COVERS SEAT AND SEAT-BACK ENSURING COMFORT AND SOFTNESS

SEDIA - CHAIR

PERLA

Design Stefano Sardonà e Sabrina Bettini



**GOOD
DESIGN
AWARD
2017**

OF CHICAGO
ATHENAEUM
MUSEUM OF
ARCHITECTURE
AND DESIGN

Sedia rivestita con struttura in acciaio e imbottitura indeformabile in schiuma di poliuretano flessibile a freddo. Gambe posteriori incrociate e schienale a goccia. Gambe verniciate. Disponibile anche in versione sgabello.

EN - Upholstered chair with steel frame and non-deforming flexible cold-foamed polyurethane. Crossed rear legs and teardrop backrest. Painted legs. Also available as a stool.

FR - Chaise revêtue avec structure en acier et rembourrage indeformable en mousse de polyuréthane flexible à froid. Pieds postérieurs croisés et dossier à goutte. Pieds vernis. Disponible aussi en version tabouret.

DE - Stuhl mit Bezug und Gestell aus Stahl sowie formstabiler Polsterung aus kalt elastischem Polyurethanschaum. Hintere Beine gekreuzt und Rückenlehne tropfenförmig. Beine lackiert. Auch als Hocker erhältlich.



PERLA

STELLA flex

Design Stefano Sandonà e Sabrina Bettini

STELLA, MOLTO PIÙ DI UNA SEDIA:
FLESSIBILE CONFORTEVOLE E
SFODERABILE

STELLA MORE THAN A CHAIR: FLEXIBLE COMFORTABLE
AND WITH REMOVABLE COVER



Sedia rivestita dotata di schienale flessibile e fasce elastiche sulla seduta, che la rendono estremamente confortevole. Telaio in acciaio e imbottitura indeformabile. Seduta e schienale sfoderabili se rifinita senza cordino. Gambe verniciate.

EN - Comfortable upholstered chair with flexible backrest and elastic seat webbing. Steel frame with non-deforming padding. Removable covers if without cord trim on seat and backrest. Painted legs.

FR - Chaise revêtue dotée de dossier flexible et de bandes élastiques sur l'assise, qui la rendent extrêmement confortable. Cadre en acier et rembourrage indéformable. Assise et dossier déhoussables si finition sans cordon. Pieds vernis.

DE - Stuhl mit Bezug und flexibler Rückenlehne sowie elastischen Bändern an der Sitzfläche, wodurch er extrem komfortabel ist. Rahmen aus Stahl und formstabile Polsterung. Sitzfläche und Rückenlehne abziehbar wenn ohne Paspel. Beine lackiert.

SEDIA - CHAIR

BRUNA flex

Design Riflessi Lab



Sedia con struttura in acciaio rivestita e rifinita con cucitura punto cavallo o due aghi. Schienale flessibile, gambe verniciate o rivestite.

EN - Chair with steel frame upholstered with blanket or twin needle stitching. Flexible backrest, painted or upholstered legs.

FR - Chaise avec structure en acier revêtue et fini avec couture point à cheval ou deux aiguilles. Dossier flexible, pieds vernis ou revêtus.

DE - Stuhl mit Gestell aus Stahl mit Bezug und Naht mit Schlingennadel oder Zwillingsnadel. Flexible Rückenlehne, Beine lackiert oder beschichtet



BRUNA flex

SEDIA - CHAIR

MARTA flex

Design Riflessi Lab



Sedia con struttura in acciaio, seduta con fasce elastiche e schienale flessibile. Rivestita e rifinita con cordino. Gambe cromate, rivestite, o verniciate.

EN - Comfortable upholstered chair with flexible backrest and elastic seat webbing. Steel frame with non-deforming padding. Removable covers without cord trim on seat and backrest. Painted legs.

FR - Chaise avec structure en acier, assise avec bandes élastiques et dossier flexible. Revêtue et fini avec corde. Pieds chromés, revêtus ou vernis.

DE - Stuhl mit Gestell aus Stahl, Sitzfläche mit elastischen Bändern und flexible Rückenlehne. Mit Bezug und Paspel. Beine verchromt, beschichtet oder lackiert.

MARTA flex



SEDIA - CHAIR

VITTORIA flex

Design Riflessi Lab



Sedia interamente rivestita con struttura in acciaio.

EN - Upholstered chair with steel frame.

FR - Chaise entièrement revêtue avec structure en acier.

DE - Komplett bezogener Stuhl mit Gestell aus Stahl.



VITTORIA flex

SEDIA - CHAIR

NINA flex

Design Riflessi Lab



Sedia rivestita e rifinita con cucitura due aghi. Struttura in acciaio con gambe rivestite, cromo o verniciate. Dotata di schienale flessibile e fasce elastiche sulla seduta che la rendono estremamente confortevole.

EN - Upholstered chair with two needle stitching. Steel frame with chromed, painted or upholstered legs. Flexible backrest and seat with elastic webbing for extra comfort.

FR - Chaise revêtue et fini avec couture deux aiguilles. Structure en acier avec pieds revêtus, chrome ou vernis. Dotée de dossier flexible et bandes élastiques sur l'assise pour la rendre extrêmement confortable.

DE - Stuhl mit Bezug und Naht mit Zwillingnadel. Gestell aus Stahl mit beschichteten, verchromten oder lackierten Beinen. Mit flexibler Rückenlehne und elastischen Bändern an der Sitzfläche, wodurch er extrem komfortabel ist.



NINA flex



SEDIA - CHAIR

SONIA flex

Design Riflessi Lab



Sedia interamente rivestita con struttura in acciaio e schienale flessibile. Applicazione di due bottoni anteriori e due posteriori.

EN - Chair with steel frame upholstered with two buttons on the front and two on the back.

FR - Chaise entièrement revêtue avec structure en acier et dossier flexible. Application de deux boutons antérieurs et deux postérieurs.

DE - Komplet bezogener Stuhl mit Gestell aus Stahl und flexibler Rückenlehne. Mit zwei applizierten Knöpfen vorne und zwei applizierten Knöpfen hinten.



SONIA flex

SEDIA - CHAIR

SLIM flex

Design Riflessi Lab



LEGGERA, LINEARE NELLA FORMA
E SOPRATTUTTO COLORATA: UN TOCCO
ORIGINALE COMPLETA IL LIVING

LIGHT, LINEAR IN SHAPE AND ESPECIALLY COLORED:
AN ORIGINAL TOUCH FOR THE LIVING AREA

Sedia rivestita con struttura in acciaio. Gambe cromo, verniciate o rivestite.

EN - Upholstered chair with steel frame and chromed, painted or upholstered legs.

FR - Chaise revêtue avec structure en acier. Pieds chrome, vernis ou revêtus.

DE - Stuhl mit Bezug und Gestell aus Stahl. Beine verchromt, lackiert oder beschichtet.

SLIM flex



SEDIA - CHAIR

LUNA flex

Design Riflessi Lab



Sedia rivestita con struttura in acciaio, gambe cromo, verniciate o rivestite. Schienale sagomato alto ed ergonomico.

EN - Upholstered chair with steel frame and chromed, painted or upholstered legs. Shaped, ergonomic high backrest.

FR - Chaise revêtue avec structure en acier, pieds chrome, vernis ou revêtus. Dossier façonné haut et ergonomique.

DE - Stuhl mit Bezug und Gestell aus Stahl, Beine verchromt, lackiert oder beschichtet. Hohe und ergonomische geformte Rückenlehne.

LUNA flex



SEDIA - CHAIR

DENISE flex

Design Riflessi Lab



Sedia rivestita con struttura in acciaio. Schienale alto o basso sagomato ergonomico e flessibile. Gambe cromate, verniciate o rivestite.

EN - Upholstered chair with steel frame and chromed, painted or upholstered legs. Shaped, ergonomic, flexible backrest

FR - Chaise revêtue avec structure en acier. Dossier haut ou bas façonné ergonomique et flexible. Pleds chromés, vernis ou revêtus.

DE - Stuhl mit Bezug und Gestell aus Stahl. Hohe oder niedrige geformte ergonomische und flexible Rückenlehne. Beine verchromt, lackiert oder beschichtet.

DENISE flex



ANNA

Design Riflessi Lab



Sedia rivestita con struttura in acciaio. Seduta e schienale imbottiti.

EN - Upholstered chair with steel frame. Padded seat and backrest.

FR - Chaise revêtue avec structure en acier. Assise et dossier rembourrés.

DE - Stuhl mit Bezug und Gestell aus Stahl. Sitzfläche und Rückenlehne gepolstert.

GAIA flex

Design Riflessi Lab



Sedia rivestita impilabile con seduta con fasce elastiche e schienale imbottiti. Struttura in acciaio. Gambe cromo, rivestite o verniciate.

EN - Stackable upholstered chair with steel frame, elastic seat and backrest padded. Chromed, upholstered or painted legs.

FR - Chaise revêtue empilable avec assise avec bandes élastiques et dossier rembourrés. Structure en acier. Pieds chrome, revêtus ou vernis.

DE - Stapelbarer Stuhl mit Bezug und gepolsterter Sitzfläche mit elastischen und Rückenlehne. Gestell aus Stahl. Beine verchromt, beschichtet oder lackiert.

SEDIA - CHAIR

EVA flex

Design Riflessi Lab



Sedia interamente rivestita con struttura in acciaio.

EN - Upholstered chair with steel frame.

FR - Chaise entièrement revêtue avec structure en acier

DE - Komplet bezogener Stuhl mit Gestell aus Stahl.

SEDIA - CHAIR

EVA flex - SARA

SARA

Design Riflessi Lab



Sedia rivestita in cuoio pieno-fiore con struttura in acciaio.

EN - Upholstered chair with steel frame. Chromed or painted legs

FR - Chaise revêtue en cuir plein-fleur avec structure en acier.

DE - Stuhl mit Bezug aus Vollnarbleder und Gestell aus Stahl.

SEDIA - CHAIR

LADY

Design Riflessi Lab



Sedia rivestita e con seduta imbottita. Schienale alto, sagomato ed ergonomico. Struttura in acciaio. Gambe cromate o verniciate

EN - Upholstered chair with steel frame and padded seat. Shaped, ergonomic, high backrest. Painted or chromed legs

FR - Chaise revêtue et avec assise rembourrée. Dossier haut, façonné et ergonomique. Structure en acier. Pieds chromés ou vernis.

DE - Stuhl mit Bezug und gepolsterter Sitzfläche. Hohe geformte und ergonomische Rückenlehne. Gestell aus Stahl. Beine verchromt oder lackiert.

SEDIA - CHAIR

LADY - VANESSA

VANESSA

Design Riflessi Lab



Sedia rivestita con struttura in acciaio. Gambe cromo o verniciate.

EN - Upholstered chair with steel frame. Chromed or painted legs

FR - Chaise revêtue avec structure en acier. Pieds chrome ou vernis.

DE - Stuhl mit Bezug und Gestell aus Stahl. Beine verchromt oder lackiert.

SEDIA - CHAIR

ALICE

Design Riflessi Lab



Sedia rivestita in cuoio pieno-fiore con struttura in acciaio.

EN - Chair with steel frame, upholstered in full-grain hide.

FR - Chaise revêtue en cuir plein-fleur avec structure en acier.

DE - Stuhl mit Bezug aus Vollnarbleder und Gestell aus Stahl.

SEDIA - CHAIR

ALICE - LILIA

LILIA

Design Stefano Sandonà e Sabrina Bettini



GOOD DESIGN AWARD 2016 OF CHICAGO ATHENAEUM : MUSEUM OF ARCHITECTURE AND DESIGN

Famiglia di sedute con scocca in tecnopolimero, dalla forma accogliente ispirata dalle forme della natura, è disponibile in plastica a vista. La pratica apertura sullo schienale le dona leggerezza e trasparenza. Gambe cromo o verniciate bianco, grafite.

EN - A family of chairs with technopolymer shells in comfortable, nature-inspired shapes, also available in visible plastic. A practical aperture in the backrest gives an effect of airiness and transparency. Legs chromed or painted in the colours white, graphite.

FR - Famille de assises avec coque en techno-polymère, à la forme accueillante inspirée par les formes de la nature, elle est disponible en plastique visible. L'ouverture pratique sur le dossier lui donne légèreté et transparence. Piètements chrome ou vernis blanc, graphite.

DE - Stuhlfamilie mit Sitzschale aus Kunststoff in schmeichelnder Form, die sich an den Formen der Natur inspiriert, erhältlich aus sichtbarem Kunststoff. Die praktische Öffnung an der Rückenlehne verleiht den Stühlen Leichtigkeit und Transparenz. Beine verchromt oder lackiert in Weiss, Graphitgrau.

SEDIA - CHAIR

PIUMA

PIUMA

Design Riflessi Lab



Sedia con struttura in metallo verniciato lucido rame o cromo. Disponibile cuscino per la seduta.

EN - Chair with structure in chrome or copper painted metal. Cushion for seat available.

FR - Chaise avec structure en métal verni brillant cuivre ou chrome. Disponible coussin pour l'assise.

DE - Stuhl mit Gestell aus lackiertem Metall Kupfer oder Chrom. Kissen für Sitzfläche erhältlich.

SPECCHIO TV - MIRROR TV

MIRROR TV

Designed by Riflessi Lab



Specchio da parete con alloggiamento per televisore, in vetro semiriflettente sp. 6 mm con supporto e telaio in alluminio finitura opaca.

EN - Wall mirror in 6mm thick semi-reflecting glass, with TV housing. Matt aluminium finish for the support and frame.

FR - Miroir au mur avec compartiment TV, en verre semi-réfléchissant ép. 6 mm avec support et cadre en aluminium finition mate.

DE - Wandspiegel mit Fernsehfach, aus halbrelektierendem Glas St. 6 mm mit Halterung und Rahmen aus Aluminium in matter Ausführung.

MIRROR TV



SHANGAI

PIANO IN CRISTALLO
TRADUZIONE

Designed by Riflessi Lab



Tavolino con gambe inclinate e sovrapposte in maniera asimmetrica con snodo centrale in frassino tinto nelle finiture a campionario o in alluminio rivestito in acciaio inox specchiante o verniciato grafite, bianco, oro rosa, ottone spazzolato a mano. Piano in cristallo temperato trasparente in appoggio o in ceramica stratificata bianco Statuario, pietra di Savoia antracite o grigio, Noir Desir lucido, Calacatta oro lucido.

EN - Coffee table with inclined, asymmetrically superimposed legs, with central articulated joint in dyed ashwood or in aluminium covered with mirror finish stainless steel, or painted in the colours graphite, white pink gold, hand brushed brass. Top in transparent, toughened glass or Statuary white, Savoy stone grey, Savoy stone anthracite, glossy Noir Desir or glossy Calacatta gold.

FR - Table avec pieds inclinés et superposés en manière asymétrique avec joint central en frêne dans les finitions d'échantillons ou en aluminium revêtu en acier inox réfléchissant ou verni grafite, bianco, oro rosa, laiton brossé à main. Plan en verre trempé transparent en appui ou en céramique stratifiée blanc Statuaire, pierre Savoie Gris, pierre Savoie anthracite, Noir Desir brillant ou Calacatta or brillant.

DE - Beistelltisch mit schrägen und asymmetrisch übereinander liegenden Beinen und Gelenk in der Mitte aus Esche in den Farben der Musterkollektion oder aus Aluminium beschichtet mit verspiegeltem Edelstahl oder lackiert in Grafite, Oro rosa, handgebürstetem Messing. Aufliegende Tischplatte aus gehärtetem transparentem Kristall oder aus Schichtkeramik in Weiß Statuario, Stein Savoyen Grau, Stein Savoyen Anthrazit, Noir Desir Hochglanz oder Calacatta Gold Hochglanz.



TAVOLINO - COFFEE TABLE

LUMIERE

PIANO IN VETRO O CERAMICA
GLASS OR CERAMIC TOP

Designed by Riflessi Lab



Tavolino con cornice in metallo verniciato grafite, oro rosa o ottone spazzolato a mano con distanziale in ottone. Piano in vetro specchiante o bronzato o in ceramica bianco statuario, pietra di Savoia antracite o grigio, Noir Desir lucido, Calacatta oro lucido.

EN - Coffee table with painted metal frame in the colours grafite, oro rosa or hand brushed brass with brass spacers. Top in mirror effect or bronze glass or Statuary white, Savoy stone grey, Savoy stone anthracite, glossy Noir Desir or glossy Calacatta gold.

FR - Table avec cadre en métal verni grafite, oro rosa ou laiton brossé à main avec entretoise en laiton. Plan en verre réfléchissant ou bronzé ou en céramique blanc Statuaire, pierre Savoie Gris, pierre Savoie anthracite, Noir Desir brillant ou Calacatta or brillant.

DE - Beistelltisch mit Rahmen aus lackiertem Metall in Graphitgrau, Rosegold oder handgebürstetem Messing mit Abstandhalter aus Messing. Tischplatte aus verspiegeltem oder bronziertem Glas oder aus Keramik in Weiß Statuario, Stein Savoyen Grau, Stein Savoyen Anthrazit, Noir Desir Hochglanz oder Calacatta Gold Hochglanz.



LUMIERE

RANDA

Design Riflessi Lab



Tavolino in cristallo curvato trasparente o cristsallo, fumè o cristallo laccato extrachiaro bianco, nero, rosso o moka.

EN - Coffee table in curved glass, transparent, fumè or extra clear lacquered in the colours white, black, red or moka.

FR - Table en verre courbé transparent ou verre, fumè ou verre laqué extra clair blanc, noir, rouge o moka.

DE - Beistelltisch aus gebogenem transparentem Kristall oder Kristall Rauchglas oder extrahellem lackiertem Kristall in Weiß, Schwarz, Rot oder Moka.

ZEN

Design Riflessi Lab



Tavolino con base in rovere a poro aperto, tinto coke o bianco e piano in cristallo.

EN - Coffee table with coke stained or white open pore oak base and glass top.

FR - Table avec base en chêne rouvre à pore ouvert, couleur coke ou blanc et plan en verre.

DE - Beistelltisch mit Gestell aus Eiche offenporig in der Farbe Nussbaum oder Weiß und Tischplatte aus Kristall.

SEGNO

Design Riflessi Lab



Complementi notte con superfici a vista incise e raccordate. Frontali, top e fianchi con con taglio a 45 gradi. Disponibili in bianco laccato opaco e tinte RAL, rovere tinto coke o cenere.

EN - Bedroom furniture with visible surfaces connected and engraved. 45° cut fronts, tops and side panels. Available in matt lacquered white or RAL colours, coke or ash stained oak.

FR - Compléments nuit avec surfaces visibles gravées et raccordées. Façades, top et côtés avec coupe à 45 degrés. Disponibles en blanc laqué mat et couleurs RAL, chêne rouvre coke ou cendre.

DE - Ergänzungselemente für den Schlafbereich mit flächenübergreifend gravierter Sichtfläche. Fronten, Deckplatte und Seitenwände mit Gehrungsschnitt. Erhältlich in Weiß Lack Matt und in den RAL-Farben, aus Eiche in der Farbe Coke oder Asche.

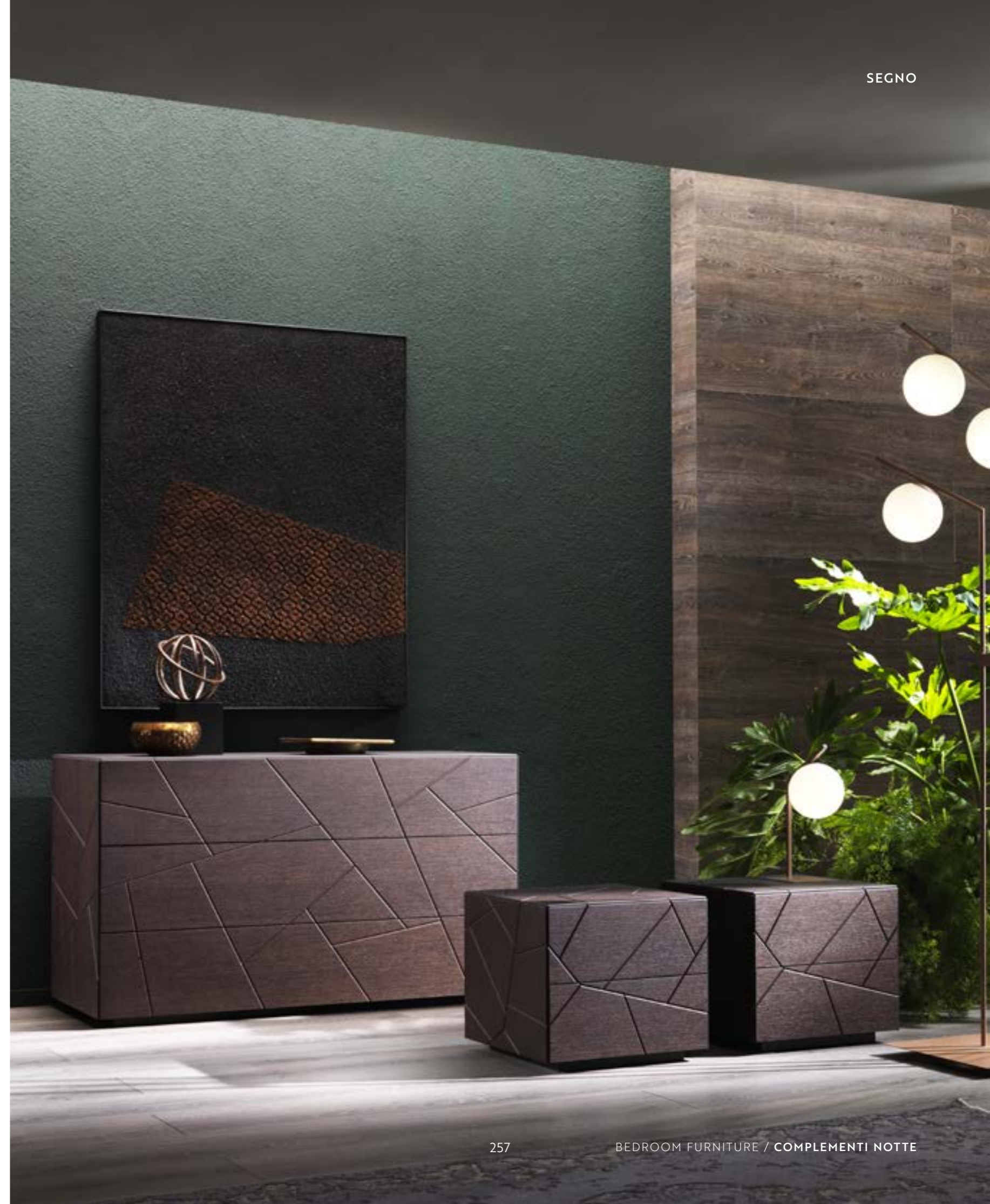

FINITURE LEGNO WOOD FINISHINGS

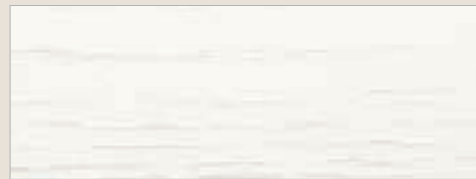

Rovere tinto bianco poro aperto
oak dyed white open-pore



Rovere tinto miele poro aperto
oak dyed honey open-pore



Rovere tinto cenere poro aperto
oak dyed ash-grey open-pore



Rovere tinto ciliegio poro aperto
oak dyed cherry wood open-pore



Rovere coke termotrattato
coke oak thermo-treated

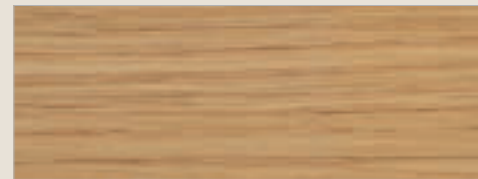

Rovere tinto naturale poro aperto
oak dyed natural open-pore



Rovere tinto tabacco poro aperto
oak dyed tobacco open-pore



Rovere tinto grigio poro aperto
oak dyed grey open-pore



Noce canaletto
american Walnut

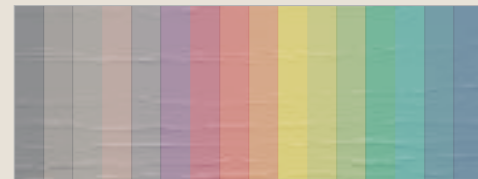

Rovere poro aperto tinto colori Ral
Ral range oak open-pore



Rovere tinto Noce poro aperto
oak dyed walnut open-pore



Rovere tinto wengé poro aperto
oak dyed wengé open-pore



Rovere tinto coke poro aperto
oak dyed coke open-pore



Rovere nodato miele
honey row oak

FINITURE LACCATE LACQUERED FINISHINGS

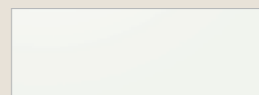

Laccato bianco opaco / lucido
matt and high gloss lacquered white



Laccato opaco / lucido colori Ral
matt and high gloss lacquered Ral range

COLORI VETRO GLASS COLOURS

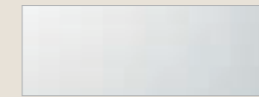

Vetro bianco opaco/lucido
matt or gloss lacquered
white glass

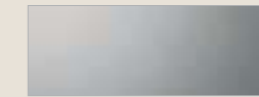

Vetro grigio opaco/lucido
matt or gloss lacquered
grey glass

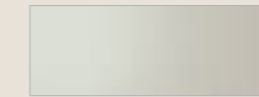

Vetro tortora opaco/lucido
matt or gloss lacquered
dove grey glass

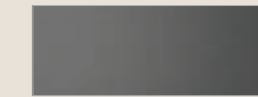

Vetro antracite opaco/lucido
matt or gloss lacquered
anthracite glass

FINITURE PIETRA STONE FOIL FINISHINGS



Pietra arenaria Rivergrey
stone foil Rivergrey



Pietra arenaria Arabik
stone foil Arabik

FINITURE CERAMICA CERAMIC FINISHINGS

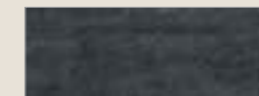

Pietra di Savoia antracite
Savoy stone anthracite



Pietra di Savoia grigio
Savoy stone grey



Bianco statuario
White Statuary



Noir Desir lucido
Gloss Noir Desir



Calacatta oro lucido
Gloss gold Calacatta

FINITURE BASI VERNICIATE SHANGAI E LIVING SHANGAI AND LIVING PAINTED BASES FINISHINGS



Grafite Graphite

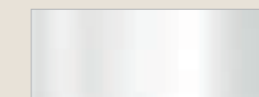

Bianco White

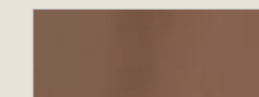

Oro rosa Gold pink



Ottone spazzolato
Brushed brass



Titanio lucido
Gloss Titanium

FINITURE IN FOGLIA LEAF FINISHINGS



Foglia argento Silver leaf



Foglia oro Gold leaf



Foglia rame Copper leaf



Foglia oro bianco White gold leaf



Foglia bronzo Bronze leaf



Foglia oro nero Black gold leaf

PELLE PIENO FIORE FULL GRAIN LEATHER COLOURS



URBAN ECO-PELLE ECO-LEATHER



CUOIO HIDE COLOURS

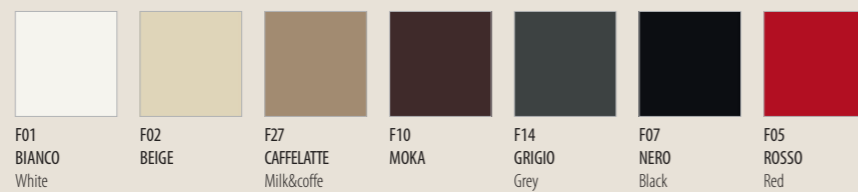

SAHARA ECO-NABUK ECO-NABUK



VELLUTO VELVET



AMALFI TESSUTO FABRIC COLOURS



CAPRI TESSUTO FABRIC COLOURS

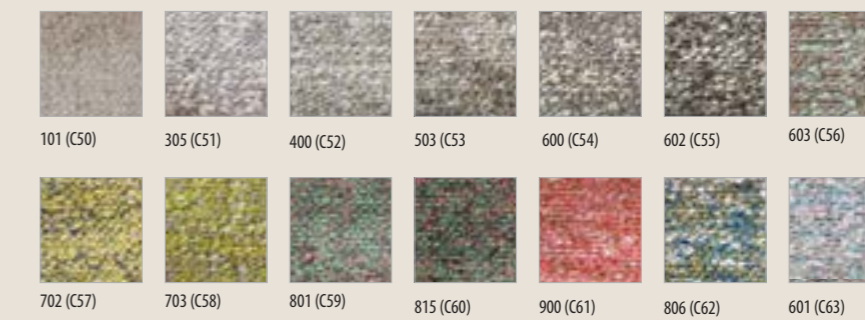

BYTE TESSUTO FABRIC COLOURS



DINAMO TESSUTO FABRIC COLOURS



BUBBLE TESSUTO FABRIC COLOURS

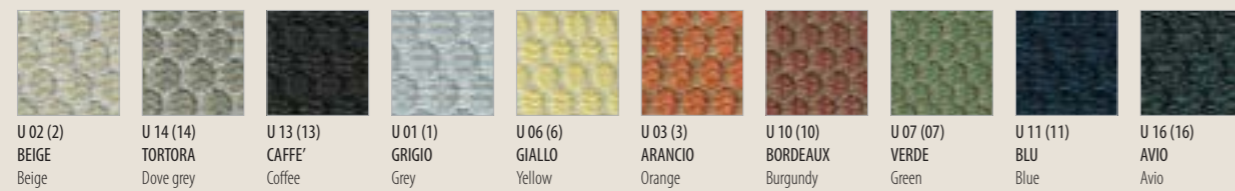

ANGEL CHEAVY FABRIC COLOURS



MAIORI TESSUTO FABRIC COLOURS

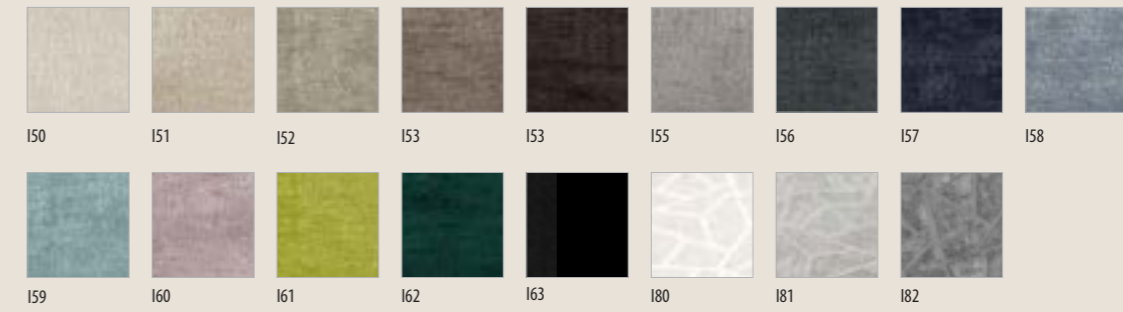

SMACCHIA

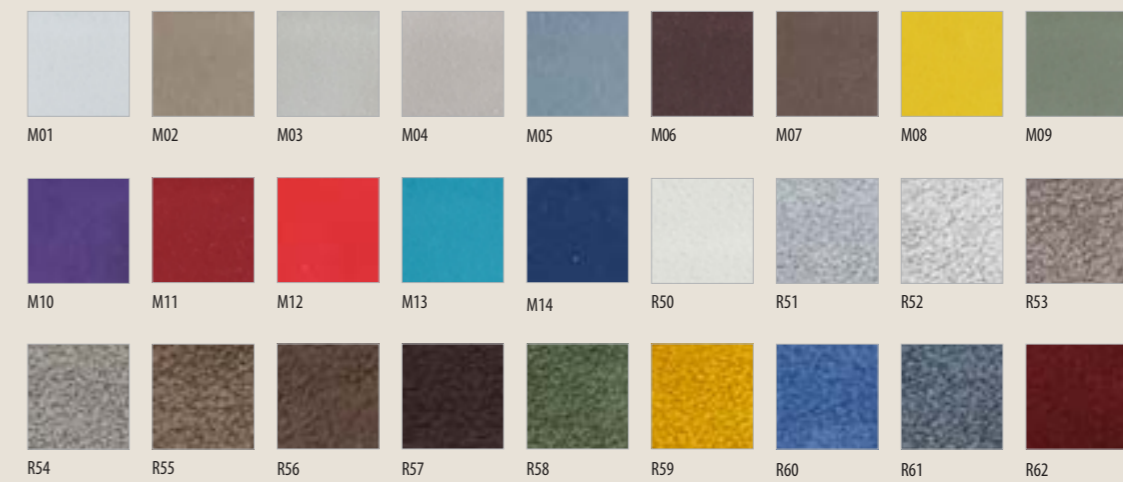

RASO SATIN
SOLO PER SEDIA SOFIA - ONLY CHAIR SOFIA



graphics: **Studio Longo**
print: **Grafiche Antiga**

Printed Marzo 2019

Riflessi s.r.l.
Contrada Cucullo, Zona Industriale
66026 ORTONA (CH) ITALIA
Tel. 085 9031054
Fax 085 9031058
commerciale@riflessi.it
www.riflessi.it

Riflessi s.r.l. si riserva di apportare in qualsiasi momento modifiche a prodotti, misure e materiali, che ritenesse utili per esigenze di carattere produttivo e commerciale. Per essere sempre aggiornati vi invitiamo a consultare il nostro sito internet www.riflessi.it. Le tonalità di colore e le finiture illustrate vanno considerate puramente indicative. Verificare sempre la fattibilità dell'abbinamento finiture consultando il listino.

Riflessi s.r.l. reserves the right to make any changes to products, dimensions and materials at any time deemed useful for manufacturing and sales purposes. To stay updated at all times, please visit our website www.riflessi.it. The colour shades and finishes illustrated herein are to be considered purely indicative. Always check the feasibility of finish combinations by consulting the price list contents.

RIFLESSI®

riflessi.it