

saba

—HARMONY  
AND  
CREATIVITY  
FOR PERFECT  
LIVING.

C—04

saba

Harmony  
and creativity for  
perfect living.

C—04



# Index

## Sofa

- 004 Pixel
- 022 Up
- 030 New York Suite
- 040 New York Soft
- 048 Livingston
- 058 Ananta Class
- 074 Essentiel
- 086 Bustier
- 090 Limes
- 104 River
- 112 Taos
- 118 Quinta Strada
- 126 Family
- 136 Karma
- 144 Opium
- 148 No logo basic
- 156 Les femmes
- 164 Valentine

## Armchair

- 170 New York Armchair
- 178 New York Bergère
- 180 New York Chair
- 184 New York Outdoor
- 188 Valentine
- 190 Bustier
- 192 Amélie
- 196 Chance
- 198 No logo light
- 200 Livingston
- 202 Essentiel
- 204 Manta
- 206 LaCarmen
- 208 Prêt à porter
- 210 Sitar

## Sofa bed

- 212 Bed & Breakfast

## Low table

- 218 A song for you
- 222 Haiku
- 226 Leyva
- 228 Più Table
- 230 Ziggy / Ziggy XL
- 236 Foulard / Foulard-ino
- 238 Honey

## Furnishing

- 242 Biscotto
- 244 Shade
- 248 Primo Quarto





# Pixel

**[IT] – Nato dalla creatività di Sergio Bicego, il divano Pixel è caratterizzato da una serie di elementi che si combinano liberamente tra loro, sfruttando un esclusivo innesto creato da Saba Italia. È così possibile scomporre i braccioli e gli schienali dalle basi per creare nuove composizioni in assoluta libertà. Le sedute in piuma sono caratterizzate dalla particolare cucitura trapuntata, che evidenzia le infinite possibilità di combinare i tessuti della collezione Saba per creare ogni volta un divano unico e personalissimo. Grazie alla particolare forma degli schienali e dei braccioli, le dimensioni complessive del divano risultano sempre molto contenute, sia in larghezza che in profondità, senza penalizzarne l'estetica. Il divano Pixel è stato accuratamente concepito in base ai criteri di ergonomia, per avere il massimo comfort su un prodotto altamente ricercato dal punto di vista stilistico. Completamente sfoderabile.**

Technical data  
— Pixel p. 254

Design Sergio Bicego  
Production year 2010  
Restyling 2014

[EN] — From the creativity of Sergio Bicego comes Pixel sofa, featuring a series of elements that can be freely combined, thanks to an exclusive connector created by Saba Italia. In this way the arm- and back-rests can be removed from the bases to form endless new arrangements. The feather-padded seat cushions feature special quilted covers which highlight the limitless possibilities for mixing the fabrics in the Saba collection to create a new and unique sofa every time. Thanks to the distinctive shape of the back- and arm-rests, the overall width and depth of the sofa are surprisingly small, without detracting from its handsome good looks. Pixel sofa has been carefully, ergonomically designed to provide the maximum comfort in a highly refined and stylish product. Fully removable covers.

[FR] — Fruit de la créativité de Sergio Bicego, le canapé Pixel est caractérisé par une série d'éléments qui se combinent librement entre eux, en exploitant un système d'accrochage exclusif créé par Saba Italia. Il est ainsi possible de séparer des bases les accoudoirs et les dossiers pour créer de nouvelles compositions en toute liberté. Les assises garnies de plume sont caractérisées par un matelassage qui souligne les nombreuses combinaisons possibles entre les tissus de la collection Saba, pour créer à chaque fois un canapé unique et très personnel. Grâce à la forme particulière des dossiers et des accoudoirs, les dimensions générales du canapé sont toujours très contenues, aussi bien en largeur qu'en profondeur, sans en pénaliser l'esthétique. Le canapé Pixel a été soigneusement conçu suivant des critères d'ergonomie, pour assurer le plus grand confort à un produit très recherché pour son style. Entièrement déhoussable.

[ES] — Fruto de la creatividad de Sergio Bicego, el sofá Pixel se caracteriza por una serie de elementos que se combinan libremente entre ellos, aprovechando de un acoplamiento exclusivo creado por Saba Italia. Es posible separar los brazos y los respaldos de las bases para crear nuevas composiciones en absoluta libertad. Los asientos de pluma se distinguen por la particular costura respunteada, que pone en evidencia las infinitas posibilidades de combinación de las telas de la colección Saba para crear cada vez un sofá exclusivo y personalizado. Gracias a la forma particular de los respaldos y de los brazos, la anchura y la profundidad del sofá resultan siempre muy reducidas sin penalizar el aspecto estético. El sofá Pixel ha sido diseñado con gran precisión respetando los criterios de ergonomía para lograr el máximo confort de un producto muy refinado desde el punto de vista estilístico. Completamente desenfundable.

Pixel

Composizione 416x214 cm in tessuto  
tavolini Haiku, paraventi Shade  
Composition 416x214 cm in fabric  
Haiku low tables, Shade divider  
Composition 416x214 cm en tissu  
table basses Haiku, paravent Shade  
Composición 416x214 cm de tela  
mesas de centro Haiku, biombo Shade



Pixel

Composizione 284x284 cm in tessuto  
tavolini Haiku  
Haiku low tables  
Composition 284x284 cm in fabric  
Haiku low tables  
Composition 284x284 cm en tissu  
table basses Haiku  
Composición 284x284 cm de tela  
mesas de centro Haiku



Pixel

Composizione 256x256 cm in tessuto  
tavolini Più  
Composition 256x256 cm in fabric  
Più low tables  
Composition 256x256 cm en tissu  
tables basses Più  
Composició 256x256 cm de tela  
mesas de centro Più





Pixel

Composizione 256x256 cm in tessuto  
tavolini Più  
Composition 256x256 cm in fabric  
Più low tables  
Composition 256x256 cm en tissu  
tables basses Più  
Composició 256x256 cm de tela  
mesas de centro Più





Pixel

Composizione 366x132 cm in tessuto  
tavolini Leyva  
Composition 366x132 cm in fabric  
Leyva low tables  
Composition 366x132 cm en tissu  
tables basses Leyva  
Composición 366x132 cm de tela  
mesas de centro Leyva





Pixel

Composizione 386x132 cm in tessuto  
tavolini Leyva  
Composition 386x132 cm in fabric  
Leyva low tables  
Composition 386x132 cm en tissu  
tables basses Leyva  
Composición 386x132 cm de tela  
mesas de centro Leyva

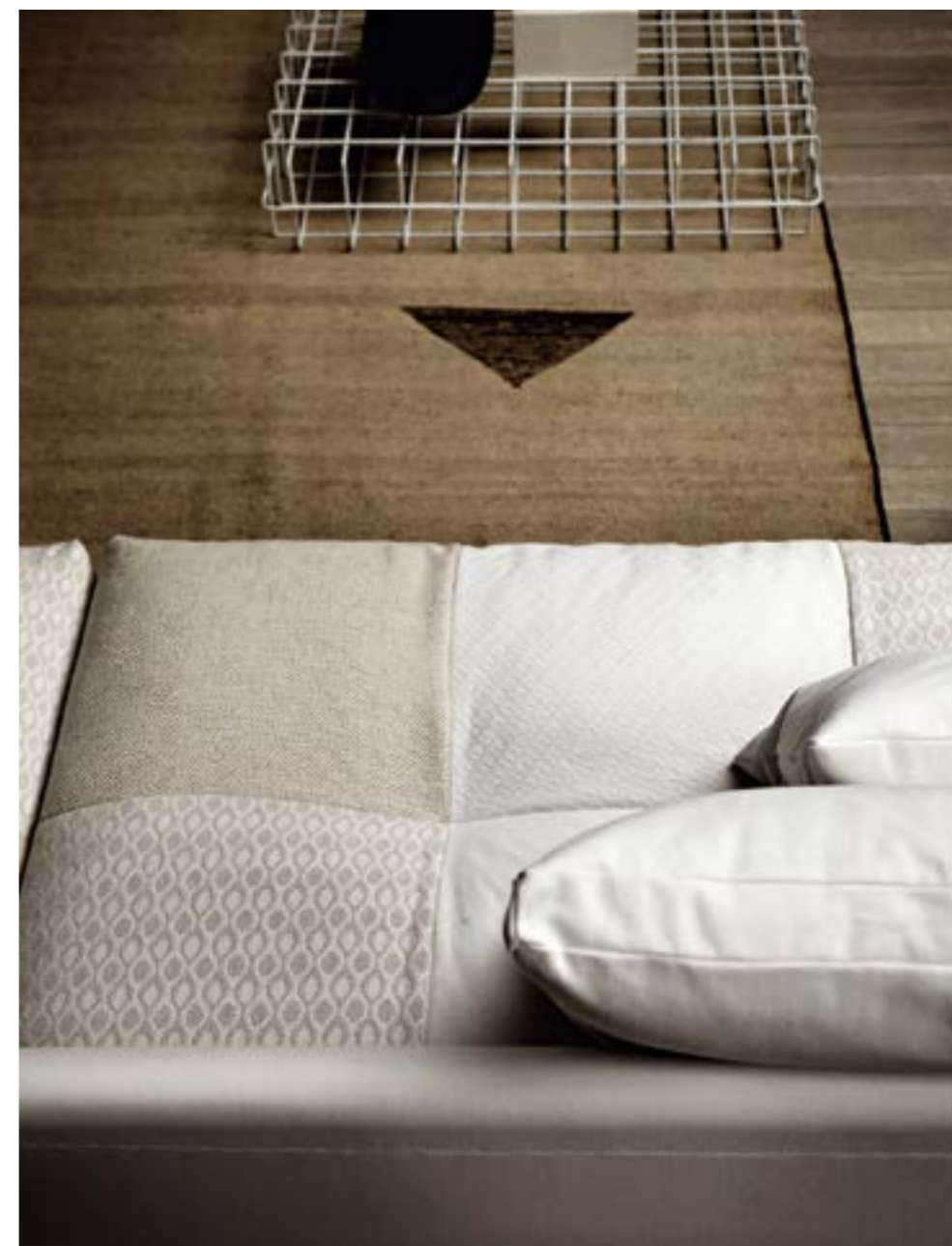

Pixel

Composizione 306x214 cm in tessuto  
Composition 306x214 cm in fabric  
Composition 306x214 cm en tissu  
Composición 306x214 cm de tela





Pixel

Composizione 224x164 cm in tessuto  
Composition 224x164 cm in fabric  
Composition 224x164 cm en tissu  
Composición 224x164 cm de tela





# Up

[IT] – **Brevetto internazionale del 2007. Up, attraverso un semplice espediente che ricorda il gioco a incastro tipico dei Lego, consente di scegliere l'altezza dello schienale che meglio corrisponde al proprio desiderio di ergonomia. L'elevazione dello schienale e il conseguente aumento della profondità di seduta si ottengono infatti appoggiando i cuscini posteriori sopra lo schienale basso. La loro particolare forma assicura la massima stabilità. L'utilizzo della piuma d'oca in tutte le cuscinature ne rivela l'anima morbida e accogliente. Disponibile in pelle con finitura "taglio a vivo".**

Technical data  
→ Up p. 257

Design Giuseppe Viganò  
Production year 2008

[EN] – International patent in 2007. Up uses a simple device similar to Lego's snap-on system to allow customers to choose the height of the backrest that best satisfies their comfort requirements. Place the back cushions on top of the low backrest to create a higher backrest and a deeper seat. The particular shape of the cushions ensures maximum stability. The goose-feather padded cushions and armrests create a particularly soft, snug sofa. Also available with raw-edged leather upholstery.

[FR] – Brevet international en 2007. Up, à travers un dispositif élémentaire qui rappelle l'encastrement typique des Lego, permet de choisir la hauteur du dossier qui correspond le mieux à l'ergonomie désirée. Le soulèvement du dossier et l'augmentation de la profondeur d'assise qui en découle s'obtiennent en effet en posant les coussins arrière sur le dossier bas. Leur forme particulière assure une stabilité parfaite. L'utilisation de la plume d'oie pour tous les coussins en révèle l'âme moelleuse et accueillante. Disponible en cuir avec bords coupés à cru.

[ES] – Patente internacional obtenida en 2007. Con un sencillo movimiento que recuerda el juego de encastramiento típico del Lego, Up permite elegir la altura del respaldo que se adapta mejor a las exigencias ergonómicas. De hecho, la elevación del respaldo y el consiguiente aumento de la profundidad del asiento se obtienen apoyando los cojines traseros sobre el respaldo bajo. Su forma particular asegura la máxima estabilidad. El uso de la pluma de ganso en toda la serie de cojines revela una textura suave y acogedora. Disponible en piel con acabado "corte en vivo".

Composizione 360x170 cm in pelle  
tavolino Leyva, tavolino Più  
Composition 360x170 cm in leather  
Leyva low table, Più low table  
Composition 360x170 cm en cuir  
table basse Leyva, table basse Più  
Composición 360x170 cm de piel  
mesa de centro Leyva,  
mesa de centro Più

Up

Divano 260x100 cm in tessuto  
tavolino Leyva  
Sofa 260x100 cm in fabric  
Leyva low table  
Canapé 260x100 cm en tissu  
table basse Leyva  
Sofá 260x100 cm de tela  
mesa de centro Leyva





Up

Divano 260x100 cm in tessuto  
Sofa 260x100 cm in fabric  
Canapé 260x100 cm en tissu  
Sofá 260x100 cm de tela





## New York Suite

[IT] – **La collezione New York firmata Sergio Bicego si declina in nuove forme senza perdere la propria essenza, costituita da un’anima contemporanea e da uno spirito senza tempo. La trapuntatura dei cuscini ammicca a un’eleganza retrò e cede alla tentazione della nostalgia per tratteggiare il design del futuro. Allo stesso tempo l’allure metropolitana viene esaltata dalla sagoma esagonale della struttura, che poggia su piedi sottili in tondino di acciaio personalizzabile, con finitura cromo nero, cromo lucido o verniciato bianco. New York Suite è avvolgente e ospitale anche nelle varianti più contenute come la maxi poltrona lounge e il divano da 155 cm, che accoglie morbidamente due persone e risulta particolarmente interessante per il sistema contract.**

Technical data  
— New York Suite p. 258

Design Sergio Bicego  
Production year 2015

[EN] — The new New York collection designs by Sergio Bicego still retain a contemporary soul and timeless spirit. The quilted cushions hint at a retro elegance and a nostalgic atmosphere yet the whole design is futuristic. At the same time the metropolitan allure is heightened by the hexagonal shape of the frame resting on slim steel rod feet with the option of customisation with a black chrome, gloss chrome or white coated finish. New York suite is soft and welcoming also in the smaller versions such as the maxi lounge chair and the 155 cm sofa which seats two people comfortably and is particularly interesting for contract projects.

[FR] — La collection New York signée Sergio Bicego est déclinée dans de nouvelles formes sans perdre son essence, une âme contemporaine et un esprit sans temps. Le matelassage des coussins évoque une élégance rétro et cède à la tentation de la nostalgie pour anticiper le design du futur. En même temps, l’allure métropolitaine est soulignée par le profil hexagonal de la structure, qui repose sur des pieds fins en fil d’acier personnalisable, avec finition chrome noir, chrome brillant ou laqué blanc. New York suite est enveloppant et accueillant, y compris dans les versions de taille plus réduite comme le maxi fauteuil lounge et le canapé de 155 cm, qui offre deux places confortables et se révèle particulièrement intéressant pour le secteur des collectivités.

[ES] — La colección New York firmada por Sergio Bicego se declina en nuevas formas sin perder su esencia, constituida por un alma contemporánea y un espíritu atemporal. El respunteado de los cojines revela una elegancia retro y cede a la tentación de la nostalgia para delinear el diseño del futuro. A su vez, la esencia metropolitana es exaltada por el perfil hexagonal de la estructura, sujeta por patas delgadas de varilla de acero personalizable, con acabado cromo negro, brillo o pintado de blanco. New York Suite es envolvente y acogedor también en las variantes más contenidas como el maxi sillón lounge y el sofá de 155 cm, que acoge con delicadeza a dos personas y es particularmente interesante por la posibilidad de personalización.

**New York Suite**

Divano 155x100 cm, 190x100 cm  
pouf 105x65 cm in tessuto, tavolino Haiku  
Sofa 155x100 cm, 190x100 cm  
pouf 105x65 cm in fabric, Haiku low table  
Canapé 155x100 cm, 190x100 cm  
pouf 105x65 cm en tissu, table basse Haiku  
Sofá 155x100 cm, 190x100 cm  
puf 105x65 cm de tela, mesa de centro Haiku





New York Suite

Divano 230x100 cm in tessuto  
pouf 140x65 cm in tessuto, tavolino Haiku  
Sofa 230x100 cm in fabric  
pouf 140x65 cm in fabric, Haiku low table  
Canapé 230x100 cm en tissu  
pouf 140x65 cm en tissu, table basse Haiku  
Sofá 230x100 cm de tela  
puf 140x65 cm de tela, mesa de centro Haiku



New York Suite

Composizione 295x165 cm in tessuto  
pouf 140x65 cm in tessuto, pouf Ziggy  
Composition 295x165 in fabric,  
pouf 140x65 cm in fabric, Ziggy pouf  
Composition 295x165 cm en tissu  
pouf 140x65 cm en tissu, pouf Ziggy  
Composición 295x165 cm de tela  
puf 140x65 cm de tela, puf Ziggy



**New York Suite**

Poltrona lounge 155x130 cm in tessuto  
Lounge armchair 155x130 cm in fabric  
Fauteuil lounge 155x130 cm en tissu  
Sillón lounge 155x130 cm de tela



**New York Suite**

Divano 230x100 cm in tessuto  
tavolini A song for you  
Sofa 230x100 cm in fabric  
A song for you low tables  
Canapé 230x100 cm en tissu  
tables basses A song for you  
Sofá 230x100 cm de tela  
mesas de centro A song for you





## New York Soft

[IT] – **L'agile silhouette della fortunata poltroncina New York è il punto di partenza del nuovo progetto di imbottiti firmato Saba. L'allure metropolitana viene esaltata dall'anima esagonale della struttura, che poggia su piedi sottili in tondino di acciaio la cui finitura cromo lucido o verniciato bianco, si arricchisce per il 2015 con la presentazione della variante cromo nero. L'anima eclettica del divano si rivela nell'originale cuscino dello schienale che consente, tramite una semplice rotazione, di tramutarsi da poggiareni a comodo poggiatesta.**

Technical data  
→ New York Soft p. 259

Design Sergio Bicego  
Production year 2013

[EN] – The lithe silhouette of the small popular New York armchair is the starting point for this new upholstered furniture design from Saba. Its metropolitan allure is enhanced by the hexagonal frame, which stands on slender steel rod feet. In addition to the white coated or gloss chrome finish, a black chrome version has been introduced for 2015. The eclectic spirit of the sofa is revealed in the original back cushion that allows you to change from backrest to comfortable headrest by simply rotating it.

[FR] – La silhouette agile du célèbre fauteuil New York est le point d'orgue du nouveau projet de meubles rembourrés signés Saba. L'allure métropolitaine est soulignée par la forme hexagonale de la structure, qui repose sur des pieds fins en fil d'acier dont la finition chrome poli ou laqué blanc s'enrichit pour 2015 avec la présentation de la variante chrome noir. L'âme éclectique du canapé se révèle dans le coussin original du dossier qui, grâce à une simple rotation, se transforme d'appui lombaire en confortable appuie-tête.

[ES] – La silueta ágil de la lograda butaca New York es el punto de partida del nuevo proyecto de muebles acolchados firmado Saba. La esencia metropolitana se exalta con la forma hexagonal de la estructura, sujeta por patas sutiles en varilla de acero, cuyo acabado cromo brillante o pintado blanco se enriquece en 2015 con la presentación de la variante cromo negro. La naturaleza ecléctica del sofá se desvela en el original cojín del respaldo que, mediante una simple rotación, se transforma de apoyo lumbar en cómodo reposacabeza.

New York Soft

Divano 260x100 cm in tessuto  
pouf Honey  
Sofa 260x100 cm in fabric  
Honey pouf  
Canapé 260x100 cm en tissu  
pouf Honey  
Sofá 260x100 cm de tela  
puf Honey



**New York Soft**

Composizione 320x165 cm in tessuto  
tavolino e pouf Ziggy, paraventi Shade  
Composition 320x165 cm in fabric  
Ziggy low table and pouf, Shade dividers  
Composition 320x165 cm en tissu  
table basse et pouf Ziggy, paravents Shade  
Composición 320x165 cm de tela  
mesa de centro y puf Ziggy, biombos Shade







New York Soft

Divano 320x165 cm in tessuto  
tavolino e pouf Ziggy  
Sofa 320x165 cm in fabric  
Ziggy low table and pouf  
Canapé 320x165 cm en tissu  
table basse et pouf Ziggy  
Sofá 320x165 cm de tela  
mesa de centro y puf Ziggy





# Livingston

**[IT] – Livingston gioca sull'effetto sorpresa tramite un uso inaspettato del poggiatesta che, con un semplice gesto di rotazione, diventa un comodo poggiatesta. È dotato di uno schienale "intelligente" accoppiato a un cuscino più piccolo tramite semplici cerniere. La seduta, soffice e informale, dialoga con una struttura aerea in acciaio che dà slancio alla generosità delle cuscinate. La particolarità dello schienale regolabile e la caratteristica del cuscino unico di seduta conferiscono al divano Livingston un profilo unico e originale, declinabile in infinite composizioni.**

Technical data  
→ Livingston p. 260

Design Giuseppe Viganò  
Production year 2009

[EN] – Livingston is refreshingly surprising with its unexpected use of the headrest: by simply twisting it, it becomes a comfortable back rest. It has a "smart" backrest, fastened to a smaller cushion using simple zips. The soft, easy seating rests on a light steel base that creates a dynamic contrast with the generous cushions. The original, adjustable backrest and its characteristic full-length seat cushions give Livingston a unique silhouette ideally suited to creating an endless variety of arrangements.

[FR] – Livingston joue sur l'effet de surprise avec un emploi inattendu de l'appuie-tête qui, par un simple geste de rotation, se transforme en appui lombaire. Il est muni d'un dossier « intelligent » accouplé à un coussin plus petit par une simple fermeture à glissière. L'assise, moelleuse et informelle, dialogue avec une structure aérienne en acier qui compense la générosité des coussins. La particularité du dossier réglable et le coussin d'assise d'un seul tenant donnent au canapé Livingston un profil unique et original, déclinable en d'infinies compositions.

[ES] – Livingston juega con el efecto sorpresa mediante el uso inesperado del reposacabeza que, con un gesto de rotación muy sencillo, se transforma en un cómodo apoyo para la espalda. Dispone de un respaldo "inteligente", asociado con un cojín más pequeño mediante simples cremalleras. El asiento, suave e informal, se completa con una estructura aérea de acero que hace resaltar a la generosidad de los cojines. La peculiaridad del respaldo ajustable y la característica del cojín único del asiento otorgan al sofá Livingston un perfil único y singular, que se declina en composiciones infinitas.

Livingston

Composizione 328x160 cm in tessuto  
tavolini Leyva  
Composition 328x160 cm in fabric  
Leyva low tables  
Composition 328x160 cm en tissu  
tables basses Leyva  
Composición 328x160 cm de tela  
mesas de centro Leyva





Livingston

Divano 240x102 cm in tessuto  
tavolini Più  
Sofa 240x102 cm in fabric  
Più low tables  
Canapé 240x102 cm en tissu  
tables basses Più  
Sofá 240x102 cm de tela  
mesas de centro Più



Livingston

Divano 240x102 cm in tessuto  
poltrona in tessuto, tavolini Più  
Sofa 240x102 cm in fabric  
in fabric armchair, Più low tables  
Canapé 240x102 cm en tissu  
fauteuil en tissu, tables basses Più  
Sofá 240x102 cm de tela, sillón de tela  
mesas de centro Più







## Ananta Class

[IT] – **Ananta Class è un sistema informale, libero e versatile che permette infinite composizioni grazie agli schienali indipendenti e alle basi da 80, 120, 160, 200 e 240 cm accostabili tra loro. Il progetto, il cui nome rimanda al concetto di infinito, parte dalla semplificazione costruttiva: le sedute, libere dai vincoli dei braccioli e delle schiene, si riorganizzano negli spazi adeguandosi alle esigenze. Il progetto è completato da un tavolino disponibile in due misure. Il supporto con finitura cromo nero sostiene un piano disponibile con impiallacciato noce canaletto o rivestito in cuoio. Un modo nuovo, democratico e contemporaneo di subordinare l'oggetto alla centralità dell'uomo. Completamente sfoderabile.**

Technical data  
→ Ananta Class p. 262

Design Sergio Bicego  
Production year 2000  
Restyling 2016

[EN] – Ananta Class is an informal and versatile modular range that allows endless combinations of the independent backrests and bases available in 80, 120, 160, 200 and 240 cm lengths. The collection, whose very name evokes the idea of infinity, is based on the idea of simplified construction: free from the constraints of armrests and backrests, the seating can be arranged to suit individual needs. It is completed with a side table available in two sizes. The black chrome rest holds up a table top available either in walnut veneer or leather. The line offers a new, individualistic, modern way of shaping things to fit people's needs. Fully removable covers.

[FR] – Ananta Class est un système informel, libre et polyvalent, qui permet un nombre illimité de compositions grâce aux dossiers indépendants et aux bases de 80, 120, 160, 200 et 240 cm juxtaposables les unes aux autres. Le projet, dont le nom renvoie au concept d'infini, part de la simplification de la construction : les assises, libérées de la contrainte des accoudoirs et des dossiers, se réorganisent dans les espaces en s'adaptant aux exigences. La proposition est complétée par une table basse, déclinée en deux taille. Le support en finition chrome noir soutient un plateau disponible en bois de noyer plaqué ou recouvert de cuir. Une nouvelle manière, démocratique et contemporaine de subordonner l'objet à la centralité de l'homme. Entièrement déhoussable.

[ES] – Ananta Class es un sistema informal, libre y versátil, que ofrece infinitas composiciones gracias a los respaldos independientes y a las bases de 80, 120, 160, 200 y 240 cm que pueden adosarse entre ellas. El proyecto evoca el concepto de infinito y parte de la simplificación constructiva: los asientos no tienen vínculos de brazos y respaldos y se reorganizan en los espacios adaptándolos a las distintas exigencias. El proyecto se completa con una mesa de centro, disponible en dos medidas. El soporte con acabado cromo negro sostiene un tablero disponible con contrachapado nogal canaletto o revestido de cuero. Una forma nueva, democrática y contemporánea de subordinar el objeto a la centralidad de la persona. Completamente desenfundable.

Ananta Class

Composizione 366x303 cm in tessuto  
pouf 80x80 cm in pelle,  
tavolini in noce canaletto  
Composition 366x303cm in fabric  
pouf 80x80 cm in leather  
tables in walnut  
Composition 366x303 cm en tissu  
pouf 80x80 cm en cuir,  
tables basses en noyer  
Composición 366x303 cm de tela  
puf 80x800 cm de piel  
mesa de centro de madera de nogal





Ananta Class

Composizione 366x303 cm in tessuto  
pouf 80x80 cm in pelle,  
tavolini in noce canaletto, New York Bergère  
Composition 366x303 cm in fabric  
pouf 80x80 cm in leather,  
tables in walnut, Bergère New York  
Composition 366x303 cm en tissu  
pouf 80x80 cm en cuir,  
tables basses en noyer, New York Bergère  
Composición 366x303 cm de tela  
puf 80x80 cm de piel  
mesa de centro de madera de nogal  
New York Bergère



Ananta Class

Composizione 326x263 cm in tessuto  
tavolini in cuoio, tavolini Più,  
poltrona Bustier  
Composition 326x263 cm in fabric  
low tables in leather,  
Più low tables, Bustier armchair  
Composition 326x263 cm en tissu  
tables basses en cuir,  
tables basses Più, fauteuil Bustier  
Composición 326x263 cm de tela  
mesas de centro de cuero  
mesas de centro Più, sillón Bustier



Saba Italia — Sofa



066

**Ananta Class**

Composizione 326x263 cm in tessuto  
tavolino in cuoio  
Composition 326x263 cm in fabric  
low table in leather  
Composition 326x263 cm en tissu  
table basse en cuir  
Composición 326x263 cm de tela  
mesa de centro de cuero



067

**Ananta Class**

Composizione 326x183 cm in tessuto  
pouf 80x80 cm, tavolino Più, poltrona Manta  
Composition 326x183 cm in fabric  
pouf 80x80 cm, Più low table, Manta armchair  
Composition 326x183 cm en tissu  
pouf 80x80 cm, table basse Più, fauteuil Manta  
Composició 326x183 cm de tela  
puf 80x80 cm, mesa de centro Più, sillón Manta



**Ananta Class**

Composizione 303x103 cm in pelle  
tavolino in noce canaletto  
tavolino Più, New York Bergère  
Composition 303x103 cm in leather  
low table in walnut  
Più low table, New York Bergère  
Composition 303x103 cm en cuir  
table basse en noyer  
table basse Più, New York Bergère  
Composición 303x103 cm de piel  
mesa de centro de madera de nogal  
mesa de centro Più, New York Bergère



Ananta Class

Composizione 366x223 cm in tessuto  
Composition 366x223 cm in fabric  
Composition 366x223 cm en tissu  
Composición 366x223 cm de tela





# Essentiel

**[IT] – Essentiel, il nuovo divano Saba, si presenta con una precisa dichiarazione di intenti. Un progetto privo di eccessi, dall'ergonomia accogliente, che nella mappa spazio-temporale del design congiunge idealmente l'eleganza storica italiana al tratto nordico. L'attenzione per i dettagli, che da sempre caratterizza le collezioni Saba, si ritrova nelle trapuntature dei cuscini schienale, nella profilatura in cordino di canetè (grigio o corda) così come nel particolare piedino verniciato corten. Essenziale nella linea ma duttile nella personalizzazione, anche i cuscini schiena nelle misure da 67 cm e 77 cm possono essere scelti nella versione alta con rullo d'appoggio. Il modello è disponibile nelle misure divano da 154 - 190 - 220 - 250 cm. I moduli si articolano in una vasta gamma di laterali, penisole e terminali per ogni esigenza di composizione. La poltrona Essentiel completa con la sua allure sofisticata questo progetto senza tempo.**

Technical data  
→ Essentiel p. 264

**Design Sergio Bicego  
Production year 2016**

[EN] – Essentiel, Saba's new sofa was born with a clear mission. Uncluttered, soft and welcoming, in design terms it magnificently fuses clean Scandinavian lines with traditional Italian flair. Saba's usual meticulous attention to detail is evident from the stitching on the backrest cushions, the grosgrain cord trim (in grey or rope colour) and the attractive Corten varnish footrest. With a minimalist silhouette, yet easy to customise, the backrest cushions (available in sizes 67 cm and 77 cm) can also be chosen in the higher version with a support roller. This sofa is available in the following sizes: 154 - 190 - 220 - 250 cm. The various modules have a vast array of side, chaise-longue and end units for endless arrangements. With its sophisticated allure, our Essentiel armchair completes this timeless collection.

[FR] – Essentiel, le nouveau canapé Saba, se présente comme une déclaration d'intention sans détours. Une proposition dépourvue d'excès, à l'ergonomie accueillante, qui à travers l'espace spatio-temporel du design conjugue idéalement la tradition d'élégance à l'italienne traditionnelle à la solidité nordique. L'attention au détail, toujours de prime importance dans les collections Saba, prend tout son sens au niveau du capitonnage du dossier, dans la densité de la surpiquûre (gris ou corde) et jusque dans le piètement en Corten patiné laqué. Essentiel est également une ligne qui sait se faire adaptable. Les dossiers existent en 67 et 77 cm et en version haut de gamme, un dossier rouleau multifonctionnel est proposé. Le modèle est disponible en version canapé dans les tailles suivantes: 154 - 190 - 220 - 250 cm. Les divers modules s'articulent dans une gamme étendue de compléments latéraux, îlots ou d'extrémité et se prêtent à toutes les combinaisons. Le fauteuil Essentiel vient parachever l'allure sophistiquée de cet ensemble parfaitement atemporel.

[ES] – Essentiel, el nuevo sofá Saba, se presenta con una declaración de intenciones precisa. Un proyecto sin excesos, de ergonomía acogedora, que en el mapa espacial-temporal del diseño une idealmente la histórica elegancia italiana al rasgo nórdico. La atención a los detalles que siempre ha caracterizado las colecciones Saba se observa en los respaldos de los cojines de los respaldos, en el perfilado en hilo de canetè (gris o cuerda) y en el particular pie pintado corten. Esenciales en la línea pero dúctiles en la personalización, los cojines del respaldo en las medidas 67 cm y 77 cm se pueden elegir en la versión alta con rodillo de apoyo. El modelo está disponible en las medidas de sofá de 154 - 190 - 220 - 250 cm. Los módulos se articulan en una amplia gama de laterales, penínsulas y terminales para cualquier exigencia de composición. El sillón Essentiel completa con su aspecto sofisticado este proyecto impercedero.

Essentiel

Divano 250x95 cm in pelle  
tavolini A song for you, tavolino Leyva  
Sofa 250x95 cm in leather  
A song for you low tables, Leyva low table  
Canapé 250x95 cm en cuir  
tables basses A song for you,  
table basse Leyva  
Sofá 250x95 cm de piel  
mesas de centro A song for you,  
mesa de centro Leyva





**Essentiel**

Composizione 370x220 cm in tessuto  
tavolini Più, poltrona Grace  
Composition 370x220 cm in fabric  
Più low tables, Grace armchair  
Composition 370x220 cm en tissu  
tables basses Più, fauteuil Grace  
Composició 370x220 cm de tela  
mesas de centro Più, sillón Grace



Saba Italia — Sofa

Essentiel

Divano 220x95 cm e  
poltrona in tessuto, tavolini Haiku  
Sofa 220x95 cm and  
armchair in fabric, Haiku low tables  
Canapé 220x95 cm et  
fauteuil en tissu, tables basses Haiku  
Sofá 220x95 cm y sillón de tela,  
mesas de centro Haiku,



**Essentiel**

Divano 220x95 cm in tessuto  
Sofa 220x95 cm in fabric  
Canapé 220x95 cm en tissu  
Sofá 220x95 cm de tela



Saba Italia — Sofa

Essentiel

design Sergio Bicego

Essentiel

Divano 220x95 cm in tessuto  
tavolini A song for you, tavolino Più  
Sofa 220x95 cm in fabric  
A song for you low tables, Più low table  
Canapé 220x95cm en tissu  
table basse A song for you, table basse Più  
Sofá 220x95 cm de tela  
mesa de centro A song for you,  
mesa de centro Più



# Bustier

**[IT] – Forme eleganti e sinuose per Bustier, un divano che trae ispirazione dai busti avvolgenti delle dame ottocentesche. Bustier si compone di una scocca rigida che abbraccia soffici cuscini in piuma prestando le sue forme a innumerevoli cambi d'abito e interpretazioni. L'ergonomia sposa dimensioni contenute (a partire da 162 x 84 cm di profondità) che ben si adattano ai contesti abitativi attuali. La collezione tessuti di Saba Italia, unica nel suo genere, interpreta in modo eclettico Bustier per arredare, decorando, sia zone living che contract. Completamente sfoderabile.**

Technical data  
→ Bustier p. 265

Design Giuseppe Viganò  
Production year 2011

[EN] — Bustier's elegant, curvy shape was inspired by the body-hugging corsets worn by ladies in the 19th century. Its rigid shell embraces soft feather cushions, and its shape means it can be adapted to many different covers and uses. Ergonomic comfort is combined with compact proportions (starting at 162 x 84 cm depth), ideal for the modern home. The unique Saba Italia fabric collection offers an eclectic selection of Bustier covers for residential or contract furnishing. Fully removable covers.

[FR] — Formes élégantes et sinueuses pour Bustier, un canapé qui s'inspire des corsets enveloppants des femmes du XIXe siècle. Bustier se compose d'une coque rigide qui enserme des coussins moelleux en plume, en prêtant ses formes à d'innombrables habillages et interprétations différentes. L'ergonomie s'allie à des dimensions contenues (à partir de 162x84 cm de profondeur) qui s'adaptent bien aux maisons et appartements d'aujourd'hui. La collection des tissus Saba Italia, unique en son genre, interprète Bustier avec éclectisme pour meubler, tout en décorant, aussi bien les livings domestiques que les espaces collectifs. Entièrement déhoussable.

[ES] — Formas elegantes y sinuosas para Bustier, un sofá que se inspira en los corsés envolventes de las damas del Ochocientos. Bustier se compone de una estructura rígida que abraza mullidos cojines de pluma, que prestan sus formas a innumerables cambios de tapicería e interpretaciones. La ergonomía se combina con dimensiones reducidas (a partir de 162x84 cm de profundidad) que se adaptan perfectamente a los espacios de las habitaciones actuales. La colección de tejidos de Saba Italia es única en su género e interpreta el espíritu de Bustier en modo ecléctico, para amueblar y decorar tanto las zonas de estar como los espacios comunitarios. Completamente desenfundable.

Bustier

Divano 222x84 cm in tessuto  
Sofa 222x84 cm in fabric  
Canapé 222x84 cm en tissu  
Sofá 222x84 cm de tela



# Limes

**[IT] – Limes è un sistema di sedute che cancella i confini, li ridisegna e li riscrive. Grazie ai pannelli reggischiena che scorrono lungo tutto il perimetro delle basi, il divano modifica il suo paesaggio plasmandosi alle esigenze del momento. Le varianti 2014 infatti, presentano una mensola rivestita in tessuto che funge da comodo appoggio. Disponibile in tre profondità - 20 cm, 40 cm o 80 cm - esplica la funzione di versatile tavolino. I pannelli reggischiena sono in metallo con finitura cromata e disponibili con fodera in tessuto, fettuccia di cotone larga 3,5 cm e la nuova finitura con fasce larghe 7 cm intrecciate sartorialmente sia in tessuto che in pelle. La sottile imbottitura interna conferisce un effetto tridimensionale ai pannelli schienale.**

Technical data  
→ Limes p. 266

Design Sergio Bicego  
Production year 2002  
Restyling 2014

**[EN] – Limes is a seating system which discards traditional boundaries and draws its own. Thanks to the back support panels running along the entire perimeter of the bases, the sofa alters its landscape by adapting to contingent needs. The 2014 versions in fact have a fabric-covered shelf for use as a handy resting surface. Available in three depths - 20 cm, 40 cm or 80 cm - it serves as a small versatile table. The back support panels are in metal with chromed finish and also available with fabric coverings, 3,5 cm wide cotton tape and the new finish with 7 cm wide bands with tailored plaiting in both fabric and leather. The thin internal padding adds a 3D effect to the back panels. Covers are fully removable.**

**[FR] – FLimes est un système de sièges qui efface les frontières, les redessine et les réécrit. Grâce aux panneaux de soutien des dossiers qui coulisent sur tout le périmètre des bases, le canapé modifie son paysage en se conformant aux exigences du moment. Les modèles 2014 en effet, présentent une étagère recouverte de tissu qui sert de plan d'appui. Disponible en trois profondeurs (20, 40 ou 80 cm) - elle a la fonction d'une table basse polyvalente. Les panneaux de soutien des dossiers sont en métal avec finition chromée, disponibles avec doublure en tissu, sangles en coton de 3,5 cm de large et dans la nouvelle finition avec des sangles entrecroisées de 7 cm de large, en tissu ou en cuir. Le fin rembourrage interne donne un effet tridimensionnel aux panneaux de soutien des dossiers. Entièrement déhoussable.**

**[ES] – Limes es un sistema de asientos que anula los límites, los vuelve a diseñar y concebir. Los paneles de soporte de la espalda que se disponen a lo largo de todo el perímetro de las bases modifican el perfil del sofá y lo plasman según las exigencias del momento. Las variantes 2014 presentan una repisa tapizada de tela que sirve de cómodo apoyo. Disponible en tres profundidades - 20 cm, 40 cm o 80 cm - se usa como una versátil mesa de centro. Los paneles que sostienen el respaldo son de metal con acabado cromo, disponibles con tapizados de tela, cinta de algodón de 3,5 cm de ancho y nuevo acabado con franjas de 7 cm de ancho trenzadas artesanalmente, de tela y de piel. El fino relleno interno otorga un efecto tridimensional a los paneles del respaldo. Completamente desenfundable.**

Limes

Composizione 300x290 cm in tessuto  
pouf e tavolino Ziggy, poltrona Amélie  
Composition 300x290 cm in fabric  
Ziggy pouf and low table, Amélie armchair  
Composition de 300x290 cm en tissu  
pouf et table basse Ziggy, fauteuil Amélie  
Composición 300x290 cm de tela  
puf y mesa de centro Ziggy, sillón Amélie





Limes

Composizione 300x100 cm in tessuto  
pouf e tavolino Ziggy, poltrona Sitar  
Composition 300x100 cm in fabric  
Ziggy pouf and low table, Sitar armchair  
Composition de 300x100 cm en tissu  
pouf et table basse Ziggy, fauteuil Sitar  
Composición 300x100 cm de tela  
puf y mesa de centro Ziggy, sillón Sitar



Limes

Penisola 132x135 cm in tessuto  
tavolino Più  
Chaise longue 132x135 cm in fabric-  
Più low table  
Module îlot 132x135 cm en tissu  
table basse Più  
Península 132x135 cm de tejido  
mesa de centro Più



Limes

Composizione 322x135 cm in tessuto  
tavolino Più, poltrona New York  
Composition 322x135 cm in fabric  
Più low table, New York armchair  
Composition 322x135 cm en tissu  
table basse Più, fauteuil New York  
Composició 322x135 cm de tela  
mesa de centro Più, sillón New York



Limes

Divani 240x98 cm in tessuto  
tavolino Leyva, poltrona Sitar  
Sofas 240x98 cm in fabric  
Leyva low table, Sitar armchair  
Canapé 240x98 cm en tissu  
table basse Leyva, fauteuil Sitar  
Sofá 240x98 cm de tela  
mesa de centro Leyva, sillón Sitar

Limes

Composizione 330x240 cm in tessuto  
tavolino Foulard  
Composition 330x240 cm in fabric  
Foulard low table  
Composition 330x240 cm en tissu  
table basse Foulard  
Composición 330x240 cm de tela  
mesa de centro Foulard





Limes

Composizione 330x240 cm in tessuto  
Composition 330x240 cm in fabric  
Composition 330x240 cm en tissu  
Composición 330x240 cm de tela



# River

**[IT] – River è un sistema di sedute dalle forme morbide che ricreano un andamento sinuoso simile al corso di un fiume. Un divano “da costruire” in estrema libertà che per attitudine ed ergonomia si presta sia a contesti abitativi che pubblici. River si avvale dell'utilizzo di materiali pregiati, poliuretani a densità differenziata di notevole elasticità e portanza, mentre lo schienale acquisisce morbidezza attraverso la presenza di maxi cuscini in piuma trapuntati. Il decoro a contrasto (che ricorda il punto-cavallo) si sviluppa lungo tutte le cuciture enfatizzandone forme e carattere per una resa allo stesso tempo elegante e casual. Completamente sfoderabile.**

Technical data  
→ River p. 268

Design Sergio Bicego  
Production year 2011

[EN] – The River seating system curves gently like a meandering watercourse. This modular seating range offers great freedom of composition, and its design and comfortable shape make it the perfect addition to residential or public settings. River is made of top quality materials, including particularly elastic, resilient variable-density polyurethane, while large, quilted feather cushions make for a particularly soft backrest. The contrasting decorative motif (reminiscent of blanket stitch) runs along the seams to emphasise their shape and character and to create an elegant, informal look. With a range of brand new fully removable covers.

[FR] – River est un système de sièges aux formes douces qui créent une ligne sinueuse semblable au cours d'un fleuve. Un canapé « à construire » en toute liberté et qui de par ses qualités esthétiques et ergonomiques, se prête aussi bien à un environnement domestique qu'aux espaces publics. River utilise des matériaux de haute qualité, des polyuréthanes à densité variable présentant une élasticité et une portance considérables, tandis que le moelleux du dossier est assuré par la présence de maxi-coussins matelassés et garnis de plumes. Le décor de couleur contrastée (qui rappelle le point de cheval) se développe le long de toutes les coutures en soulignant la forme et le caractère pour un résultat à la fois élégant et décontracté. Entièrement déhoussable, il est disponible dans de nouveaux revêtements.

[ES] – River es un sistema de asientos de formas delicadas que reproducen una línea sinuosa, similar al curso de un río. Un sofá que se construye en libertad, que por su espíritu y ergonomía puede usarse en ambientes residenciales y públicos. River utiliza materiales de gran calidad, poliuretanos de densidad diferenciada que ofrecen una gran elasticidad y sustentación, mientras que el respaldo adquiere una consistencia más mullida gracias a los maxicojines de pluma pespunteados. La decoración en contraste (recuerda el punto festón) se extiende en todas las costuras enfatizando las formas y el carácter con un resultado elegante y, al mismo tiempo, informal. Completamente desenfundable.

River

Composizione 367x202 cm in tessuto  
pouf ovale, tavolino Foulard  
Composition 380x220 cm in fabric  
oval pouf, Foulard low table  
Composition 380x220 cm en tissu  
pouf ovale, table basse Foulard  
Composición 380x220 cm de tela  
puf ovalado, mesa de centro Foulard





### River

Composizione 200x196 cm in tessuto  
pouf ovale, tavolino Foulard  
Composition 200x196 cm in fabric  
oval pouf, Foulard low table  
Composition 200x196 cm en tissu  
pouf ovale, table basse Foulard  
Composición 200x196 cm de tela  
puf ovalado, mesa de centro Foulard





River

Divano 270x126 cm in tessuto  
pouf 110x90 cm  
Sofa 270x126 cm in fabric  
pouf 110x90 cm  
Canapé 270x126 cm en tissu  
pouf 110x90 cm  
Sofá 270x126 cm de tela  
puf 110x90 cm





# Taos

**[IT] – La collezione Taos è composta da divani singoli dal design innovativo, le cui sedute-pouf, indipendenti dalla struttura, permettono di trasformare il divano in chaise longue o letto sommier. I pouf scorrono su ruote e consentono di aumentare la profondità di seduta al centimetro; nessun meccanismo, solo un gesto semplice e certo a garantirne la funzionalità. La struttura di Taos è in legno e acciaio, le sedute sono in piuma d’oca lavata, sterilizzata e coperta con tela di cotone oppure, a scelta, in espanso a quote differenziate. I piedi sono in acciaio cromato. Completamente sfoderabile.**

Technical data  
→ Taos p. 270

Design Sergio Bicego  
Production year 1999  
Restyling 2010

[EN] – The Taos Collection consists of innovatively-designed individual sofas with separate pouf-seats that can be moved to turn the sofa into a chaise longue or a bed. The poufs are set on casters, and with a simple, efficient movement, can be pulled forward to create a deeper sofa seat, making them even more user-friendly. Taos has a wood and steel frame, while the seats are padded with sanitized goose down covered in cotton canvas or, alternatively, with variable-density polyurethane foam. Chrome-steel feet. Fully removable covers.

[FR] – La collection Taos est composée de canapés au design innovant, dont les assises-pouf, indépendantes de la structure, permettent de transformer le canapé en chaise longue ou banquette-lit. Les poufs se déplacent sur roulettes et permettent d’augmenter la profondeur d’assise au centimètre près ; aucun mécanisme, il suffit d’un geste simple et sûr pour en garantir la fonctionnalité. La structure de Taos est en bois et acier, les assises sont garnies de plumes d’oie lavée, stérilisée et revêtue de toile de coton ou, au choix, en mousse de densité variable. Les pieds sont en acier chromé. Entièrement déhoussable.

[ES] – La colección Taos se compone de sofás individuales de diseño innovador; los pufs son independientes de la estructura y permiten transformar el sofá en una chaise longue o cama somier. Los pufs se desplazan sobre ruedas y permiten aumentar la profundidad del asiento al centímetro; ningún mecanismo, sólo un gesto sencillo y seguro para garantizar la funcionalidad. La estructura de Taos es de madera y acero, los asientos son de pluma de ganso lavada, esterilizada y cubierta con tela de algodón o bien, a elección, en espuma de densidad diferenciada. Las patas son de acero cromado. Completamente desfundable.

Taos

Divano 295x200 cm in tessuto  
tavolini Foulard, Foulard-ino  
poltrona Prêt-à-porter  
Sofa 295x200 cm in fabric  
Foulard, Foulard-ino low tables  
Prêt-à-porter armchair  
Canapé 295x200 cm en tissu  
tables basses Foulard, Foulard-ino  
fauteuil Prêt-à-porter  
Sofá 295x200 cm de tela  
mesas de centro Foulard, Foulard-ino  
sillón Prêt-à-porter





**Taos**

Composizione in tessuto  
Composition in fabric  
Composition en tissu  
Composición de tela





## Quinta Strada

**[IT] – Progettato nel 1996, il sistema di seduta Quinta Strada, è stato un progetto “pioniere” dello stile moderno. Rigoroso ma flessibile nella componibilità, viene ora rieditato attraverso un restyling attento ai dettagli del nuovo linguaggio contemporaneo. La finitura cromo nero del piede, l’assottigliamento delle staffe di congiunzione, la leggerezza della base e del supporto schienale sono gli eleganti particolari adeguati al moderno living. I diversi elementi della collezione Quinta Strada permettono numerose configurazioni, consentendo composizioni particolarmente interessanti anche nelle situazioni ad angolo.**

Technical data  
→ Quinta Strada p. 272

Design Sergio Bicego  
Production year 1996  
Restyling 2015

[EN] — Brought out in 1996, the Quinta Strada seating range was a pioneering design in true modern style. Streamlined yet modularly flexible, the range is now re-produced with a sensitive restyling that is mindful of the new contemporary language. The black chrome finish of the feet, the thinner joining clamps and the lightness of the base and back support are elegant touches in step with the modern lifestyle. The various pieces in the Quinta Strada collection allow for numerous configurations and particularly interesting compositions even in corner situations.

[FR] — Conçu en 1996, le système de sièges Quinta Strada a été un projet « pionnier » du style moderne. Rigoureux mais flexible dans ses possibilités de composition, il est maintenant réédité à travers un restyling attentif aux détails du nouveau langage contemporain. La finition noir chrome du pied, la finesse des éléments de raccordement, la légèreté de la base et du support du dossier, sont les détails élégants adaptés à un living moderne. Les différents éléments de la collection Quinta Strada permettent de nombreuses configurations, en donnant vie à des compositions particulièrement intéressantes également dans les solutions d’angle.

[ES] — Diseñado en 1996, el sistema de asientos Quinta Strada representa un proyecto “pionero” del estilo moderno. Riguroso aunque flexible en su composición, se repropone con un diseño actualizado, atento a los detalles del nuevo lenguaje contemporáneo. El acabado negro cromo de la pata, el afinamiento de las abrazaderas de unión, la ligereza de la base y del soporte del respaldo, son detalles elegantes perfectos para el vivir moderno. Los distintos elementos de la colección Quinta Strada ofrecen la posibilidad de crear numerosas configuraciones, permitiendo composiciones particularmente interesantes, también para los modelos de esquina.

**Quinta Strada**

Composizione 330x205 cm in tessuto  
pouf e tavolino Ziggy, New York Bergère  
Composition 330x205 cm in fabric  
Ziggy pouf and low table, New York Bergère  
Composition 330x205 cm en tissu  
pouf et table basse Ziggy, New York Bergère  
Composición 330x205 cm de tela  
puf y mesa de centro Ziggy, New York Bergère





### Quinta Strada

Divano 238x95 cm in tessuto  
tavolino Haiku  
Sofa 238x95 cm in fabric  
Haiku low table  
Canapé 238x95 cm en tissu  
table basse Haiku  
Sofá 238x95 cm de tela,  
mesa de centro Haiku



Quinta Strada

Composizione 318x150 cm in tessuto,  
pouf e tavolini Honey  
Composition 318x150 cm in fabric,  
Honey pouf and low tables  
Composition 318x150 cm en tissu,  
pouf et tables basses Honey  
Composición 318x150 cm  
de tela, puf y mesas de centro Honey







## Family

[IT] — Il nuovo divano Family parte dal desiderio di approfondire la ricerca sui divani essenziali e dall'uso trasversale. Un comodissimo pozzetto dalle svariate misure diventa unico e diverso dagli standard attuali. I tre moduli cuscino (piccolo, medio, grande) sono intercambiabili e possono essere inseriti in ordine ogni volta diverso, modificando il ritmo della sequenza della cuscineria e suggerendo, a piacere, anche la possibilità di un gioco di contrasti cromatici. Completamente sfoderabile.

Technical data  
→ Family p. 274

Design Marzia e Leonardo Dainelli  
Production year 2012

[EN] — The new Family sofa is the fruit of an in-depth study of simple, multi-use couches. An ultra-comfortable tub shape in a range of sizes becomes something unique that breaks with current norms. The three cushion sizes (small, medium, large) are interchangeable and can be arranged in a different order each time, thereby giving a new slant to the cushion array and offering the option of contrasting colour sequences if desired. Fully removable covers.

[FR] — Le nouveau canapé Family naît du désir d'approfondir la recherche sur les canapés essentiels permettant une utilisation transversale. Une structure baquet confortable de dimensions variées devient unique et se différencie des standards actuels. Les trois modules de coussin (petit, moyen, grand) sont interchangeables et peuvent être disposés dans un ordre à chaque fois différent, en modifiant le rythme de la séquence et en offrant éventuellement la possibilité de jouer sur les couleurs. Entièrement déhoussable.

[ES] — El deseo de adentrarse en el estudio de los sofás esenciales y de uso transversal es el punto de partida para el nuevo sofá Family. Una comodísima bañera de varias medidas, única y diferente respecto a los estándares actuales. Los tres módulos del cojín (pequeño, mediano y grande) son intercambiables y pueden ocupar posiciones diferentes cada vez, modificando el ritmo de la secuencia de los cojines y sugiriendo, según el ánimo, también la posibilidad de un juego de contrastes cromáticos. Completamente desenfundable.

Family

Divano 300x98 cm in tessuto  
poltrona Amélie, tavolini A song for You  
Sofa 300x98 cm in fabric  
Amélie armchair, A song for you low tables  
Canapé 300x98 cm en tissu  
fauteuil Amélie, table basse A song for you  
Sofá 300x98 cm de tela  
sillón Amélie, mesa de centro A song for you



Family

Composizione 300x293 cm  
in tessuto, pouf Biscotto, tavolini Più  
Composition 300x293 cm in fabric  
Biscotto pouf, Più low table  
Composition 300x293 cm en tissu  
Pouf Biscotto, tables basses Più  
Composició 300x293 cm de tela  
puf 110x90 cm, mesas de centro Più





Family

Pouf 98x98 cm  
Pouf 98x98 cm  
Pouf 98x98 cm  
Puf 98x98 cm



Family

Composizione 293x98 cm in tessuto  
poltrone Amélie, tavolini A song for You  
Composition 293x98 cm in fabric  
Amélie armchairs, A song for you low tables  
Composition 293x98 cm en tissu, fauteuil Amélie  
tables basses, A song for you  
Composición 293x98 cm de tela, sillones Amélie  
mesas de centro A song for you





# Karma

**[IT] – La collezione Karma incarna meglio di qualunque altro la versatilità dei prodotti di Saba Italia: un divano che trova posto sia negli ambienti moderni che nelle abitazioni di impronta più classica. Il successo di Karma cavalca così gli anni e le tendenze, grazie a un'attenzione nei dettagli quasi maniacale. I suoi 110 cm di profondità diventano agili per merito di accorgimenti stilistici che ne esaltano l'importanza senza appesantirlo. Proporzioni raffinate, design senza tempo e grande adattabilità a qualsiasi tipo di rivestimento fanno di Karma un divano irrinunciabile. Completamente sfoderabile.**

Technical data  
→ Karma p. 275

Design Sergio Bicego  
Production year 1999  
Restyling 2013

[EN] – The Karma collection is the ultimate expression of the versatility of Saba Italia products: a sofa that fits seamlessly into both modern settings and more classical homes. Karma has been riding the wave of success through passing years and fleeting fashions, thanks to its almost obsessive attention to detail. Design details ensure comfortable seating despite its depth of 110 cm, and add to its substance without weighing it down. Elegant proportions, timeless design and absolute suitability for any type of covering make Karma feel like the sofa of your destiny. Fully removable covers.

[FR] – La collection Karma incarne mieux que toute autre la flexibilité des créations Saba Italia : un canapé qui trouve sa place aussi bien dans les intérieurs modernes que dans les contextes de style plus classique. Le succès de Karma traverse ainsi les années et les modes, grâce à une attention pour les détails qui frise l'obsession. Ses 110 cm de profondeur sont relativisés par des solutions de style qui en exaltent l'importance sans l'alourdir. Des proportions raffinées, un design sans âge et une grande adaptabilité à n'importe quel type de revêtement font de Karma une valeur sûre. Entièrement déhoussable.

[ES] – La colección Karma encarna mucho mejor que cualquier otra la versatilidad de los productos de Saba Italia: un sofá que encuentra su colocación tanto en los espacios modernos como en las habitaciones de estilo más clásico. El éxito de Karma supera los años y las tendencias, gracias a una atención meticulosa a los detalles. Sus 110 cm de profundidad se hacen ágiles por mérito de soluciones estilísticas que exaltan su importancia sin añadir pesadez. Las proporciones refinadas, el diseño atemporal y la gran adaptabilidad a cualquier tipo de tapizado hacen de Karma un sofá irrenunciable. Completamente desenfundable.

Karma

Divano 300x110 cm in tessuto  
poltrona New York, tavolini Più  
Sofa 300x110 cm in fabric  
New York armchair, Più low tables  
Canapé 300x110 cm en tissu  
fauteuil New York, tables basses Più  
Sofá 300x110 cm de tela  
sillón New York, mesas de centro Più



Karma

Composizione 300x160 cm in tessuto  
tavolino Foulard  
Composition 300x160 cm in fabric  
Foulard low table  
Composition 300x160 cm en tissu  
table basse Foulard  
Composición 300x160 cm de tela  
mesa de centro Foulard

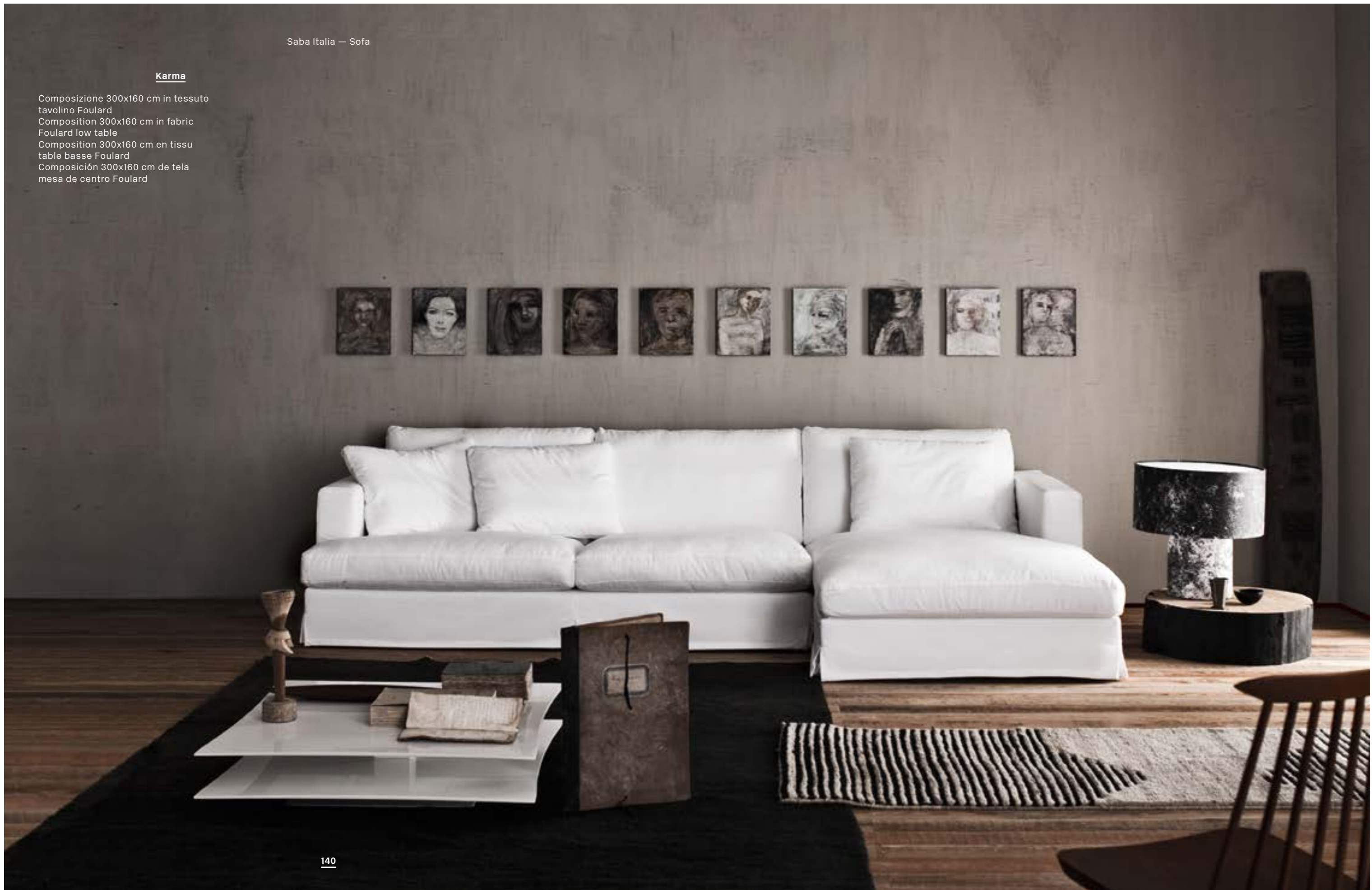





**Karma**

Composizione 300x160 cm in tessuto  
Composition 300x160 cm in fabric  
Composition 300x160 cm en tissu  
Composición 300x160 cm de tela





# Opium

**[IT] – Non può mancare un modello che omaggia i fasti del recente passato. Opium, già dal nome, delinea la sua natura bohemien con garbo ed eleganza, arricchendo l'ambiente di un fascino che affonda le radici nella nostra storia. Al tema spiccatamente classico sono stati accostati degli elementi che ne alleggeriscono l'impronta, come i piedini in alluminio tornito e un certo rigore formale della struttura, che lascia poi spazio al comfort e all'accoglienza dei cuscini in piuma. Anche componibile in versione angolare e con chaise longue.**

Technical data  
→ Opium p. 276

Design Sergio Bicego  
Production year 1996

[EN] – No collection would be complete without a model that pays homage to the splendours of the recent past. Even the name Opium bespeaks its Bohemian nature, and its grace and elegance will bestow upon any setting a charm that sinks its roots deep into our history. The markedly classical theme is accompanied by elements that add lightness, such as the feet in turned aluminium, and the precise shape of the structure, which give way to the cosy comfort of the feather cushions. Also available in a modular corner version and chaise longue.

[FR] – Il ne pouvait manquer dans la collection un modèle rendant hommage aux fastes du passé récent. Opium, à travers son nom déjà, annonce sa nature bohème avec classe et élégance, en apportant à l'espace qui l'accueille un charme qui plonge ses racines dans notre histoire. Au thème fortement classique ont été associés des éléments qui en allègent la ligne, comme les pieds en aluminium tourné et une certaine rigueur formelle de la structure, qui laisse place toutefois au confort en accueillant des coussins en plumes. Version d'angle également modulaire et chaise longue.

[ES] – No puede faltar un modelo que celebra los triunfos del reciente pasado. Opium, ya del nombre, hace clara su inspiración bohemia con gracia y elegancia, enriqueciendo el ambiente de un encanto que hunde sus raíces en nuestra historia. Al tema incuestionablemente clásico se asocian elementos para aligerar su carácter, como las patas de aluminio torneado y un cierto rigor formal de la estructura, que deja espacio al confort y a la disposición de los cojines de pluma. También disponible en versión modular de esquina y con chaise longue.

Opium

Divano 240x106 cm in tessuto  
Sofa 240x106 cm in fabric  
Canapé 240x106 cm en tissu  
Sofá 240x106 cm de tela



# No logo basic

**[IT] – Il modello No logo, in produzione dal 2005, nasce con l'esplicito intento di interpretare le forme essenziali del divano con una personalità sofisticata ma non aggressiva. Un modello che incontra le esigenze di chi considera la semplicità un punto d'arrivo, aldilà delle mode e della frenesia progettuale. No logo è arricchito da alcuni particolari ricercati, come la forma slanciata dei braccioli e la particolare coloritura nichelata delle gambe in acciaio. Chi sceglie No logo lo guarderà ogni giorno nella sua casa con rinnovato interesse.**

Technical data  
→ No logo basic p. 277

Design Sergio Bicego  
Production year 2005  
Restyling 2012

[EN] – Created in 2005, No Logo was designed with the specific intention of interpreting the essential sofa shape with a sophisticated yet friendly personality. A model to meet the needs of people for whom simplicity is the key aspiration, above and beyond fashions, fads and frenzied designs. No Logo is enhanced with a number of refined details, such as the sleek shape of the armrests and the distinctive nickeled steel legs. No Logo owners will be captivated by it each waking day.

[FR] – Le modèle No Logo, en production depuis 2005, naît avec l'intention explicite d'interpréter les formes essentielles du canapé avec une personnalité raffinée mais non imposante. Un modèle qui rencontre les exigences de qui considère la simplicité comme un point d'arrivée, au-delà des modes et du design exacerbé. No Logo est enrichi de quelques détails raffinés, comme la forme élancée des accoudoirs et la teinte nickelée particulière des pieds en acier. Qui choisit No Logo l'admira chaque jour, dans son cadre domestique, sans jamais se lasser.

[ES] – El modelo No Logo, fabricado desde 2005, nace con la intención explícita de interpretar las formas esenciales del sofá con una personalidad sofisticada pero no agresiva. Un modelo que responde a las exigencias de quien considera la simplicidad un punto de llegada, más allá de las modas y del ansia de proyectar. No Logo se enriquece con algunos detalles refinados, como la forma esbelta de los brazos y la singular tonalidad niquelada de las patas de acero. Quien elige No Logo lo admirará continuamente en el interior de su casa con renovado interés.

No logo basic

Composizione 322x178cm in tessuto  
tavolino Più  
Composition 322x178 cm in fabric  
Più low table  
Composition 322x178 cm en tissu  
table basse Più  
Composició 322x178 cm de tela  
mesa de centro Più





**No logo basic**

Composizione 322x178cm in tessuto  
Composition 322x178 cm in fabric  
Composition 322x178 cm en tissu  
Composición 322x178 cm de tela



No logo basic

Divano 266x100 cm in pelle  
poltrona No logo light, tavolino Leyva  
Sofa 266x100 cm in leather  
No logo light armchair, Leyva low table  
Canapé 266x100 cm en cuir  
fauteuil No logo light, table basse Leyva  
Sofá 266x100 cm de piel  
sillón No logo light, mesa de centro Leyva





## Les femmes

Design Giuseppe Viganò  
Production year 2009

[IT] – **Les Femmes è un divano componibile dallo schienale alto e dalla seduta accogliente, caratterizzato da forme morbide e avvolgenti. L'originale progetto consente con solo tre moduli la massima libertà compositiva: la possibilità di variare le posizioni dello schienale e del bracciolo lo rende infatti un sistema giocoso ed estremamente versatile. Con schienale e bracciolo rialzati, Les Femmes è un divano intimo e rassicurante, con bracciolo reclinabile è sfizioso e accattivante, con schienale reclinabile è girovago e divertente. Lo schienale e il bracciolo possono essere reclinati verso l'esterno attraverso un particolare congegno a "snodo" che ne permette un movimento fluido e rapido tramite un semplice gesto della mano.**

Technical data  
→ Les femmes p. 278

[EN] – Les Femmes is a modular couch with a high backrest and a comfortable seat, characterized by its soft, enveloping shape. Using just three elements, its original design permits a wide variety of arrangements. The position of the backrest and armrest can be varied, creating an appealing, versatile seating range. With raised backrest and armrest, Les Femmes is a snug, reassuring sofa; with the armrest lowered it is amusing and winsome; lowering the backrest makes it feisty and fun. The backrest and the armrest can be folded outwards using a special swivel device which enables a quick, fluid manoeuvre with a simple flick of the wrist.

[FR] – Les Femmes est un canapé modulable, comprenant un dossier haut et une assise accueillante, caractérisé par des formes douces et enveloppantes. Avec seulement trois modules, ce projet original permet une grande liberté de composition : la possibilité de modifier les positions du dossier et de l'accoudoir en fait un système dynamique et extrêmement flexible. Avec le dossier et l'accoudoir relevés, Les Femmes est un canapé intime et rassurant ; avec l'accoudoir replié, il devient séduisant et prêt à donner corps à toutes les fantaisies ; avec le dossier replié, il prend un air baroudeur et amusant. Le dossier et l'accoudoir peuvent être repliés vers l'extérieur à travers un mécanisme articulé particulier qui permet un mouvement fluide et rapide, un simple geste de la main.

[ES] – Les Femmes es un sofá componible de respaldo alto y asiento acogedor, caracterizado por formas delicadas y envolventes. El proyecto original con sólo tres módulos ofrece una gran libertad de composición: la posibilidad de modificar las posiciones del respaldo y del brazo que lo convierte en un sistema sumamente versátil. Con el respaldo y el brazo levantados, Les Femmes es un sofá íntimo y confortante, su brazo reclinable es extravagante y encantador, su respaldo reclinable es móvil y divertido. El respaldo y el brazo pueden reclinarse hacia afuera mediante un sistema articulado especial que permite un movimiento fluido y rápido con sólo mover una mano.



Les femmes

Composizione 244x95 cm in tessuto  
poltrona Sitar, tavolino Foulard-ino  
Composition 244x95 cm in fabric  
Sitar armchair, Foulard-ino low table  
Composition 244x95 cm en tissu  
fauteuil Sitar, table basse Foulard-ino  
Composició 244x95 cm de tela  
sillón Sitar, mesa de centro Foulard-ino



Saba Italia — Sofa



Les femmes

Composizione 244x95 cm in tessuto  
tavolino Foulard-ino  
Composition 244x95 cm in fabric  
Foulard-ino low table  
Composition 244x95 cm en tissu  
table basse Foulard-ino  
Composición 244x95 cm de tela  
mesa de centro Foulard-ino





Les femmes

Composizione 190x95 cm in tessuto  
pouf 95x95 cm in tessuto  
tavolini Più, poltrona LaCarmen  
Composition 190x95 cm in fabric  
pouf 95x95 cm in fabric, Più low tables  
LaCarmen armchair  
Composition 190x95 cm en tissu  
pouf en tissu 95x95 cm, tables basses Più  
fauteuil La Carmen  
Composición 190x95 cm de tela  
puf 95x95 cm de tela, mesas de centro Più  
sillón La Carmen





# Valentine

**[IT] – Una serie di sedute dal gusto informale con contenuti di praticità e comfort elevati. Le forme morbide, ispirate agli anni '70, rendono Valentine versatile senza trascurare il lato estetico-funzionale. Un appeal estremamente "solido", quasi monolitico, cela un'anima inaspettatamente leggera: una delle sue caratteristiche principali risiede infatti nei materiali scelti per le imbottiture che permettono un facile trasporto dei moduli. Completamente sfoderabile.**

Technical data  
→ Valentine p. 279

Design Marzia e Leonardo Dainelli  
Production year 2012

[EN] – A line of seating featuring an informal style, superior comfort and practicality. The soft, 70s-inspired shapes make the Valentine collection versatile while maintaining its aesthetic and functional appeal. A very "solid", almost monolithic quality hides an unexpected lightness: one of its great features is the choice of materials for the padding, which make for easy transportation of the units. Fully removable covers.

[FR] – Une série de sièges au goût informel avec des contenus d'une praticité et d'un confort élevés. Les formes moelleuses, s'inspirant des années 70, assurent la polyvalence de Valentine, sans négliger le côté esthétique et fonctionnel. Une conception extrêmement compacte presque monolithique, cache une âme étonnamment légère : l'une de ses principales caractéristiques réside en effet dans les matériaux choisis pour le rembourrage qui permettent un transport aisé des éléments. Entièrement déhoussable.

[ES] – Una serie de asientos de gusto informal, muy prácticos y confortables. Las formas suaves, inspiradas en los Setenta, hacen de Valentine un modelo versátil, sin olvidar el lado estético-funcional. Una sólida capacidad de atracción, casi monolítica que esconde un alma inesperadamente ligera: una de sus características principales se focaliza en los materiales usados para los rellenos que facilitan el transporte de los módulos. Completamente desenfundable.

Valentine

Divano 150x100 cm in tessuto  
poltrona Valentine, tavolino Più  
Sofa 150x100 cm in fabric  
Valentine armchair, Più low table  
Canapé 150x100 cm en tissu  
fauteuil Valentine, table basse Più  
Sofá 150x100 cm de tela, sillón Valentine  
mesa de centro Più



**Armchairs, Sofa bed,  
Low tables  
and Furnishings**

**C—04**





## New York Armchair

**[IT] – New York è una collezione che porta con fierezza il nome della Grande Mela. Due anime, uptown e downtown, racchiuse in un unico oggetto di design il cui rivestimento, interamente intercambiabile, ne svela l'innata versatilità. L'insolita e poliedrica ergonomia della poltroncina New York invita a un uso personale del rivestimento e al bicolore, permettendo diverse soluzioni cromatiche attraverso un'unica scelta. La struttura è in tondino di ferro disponibile in molteplici finiture sia di cromatura che di verniciatura. Completamente sfoderabile.**

Technical data  
→ New York Armchair p. 280

Design Sergio Bicego  
Production year 2012

[EN] – New York, a collection which proudly bears the name of the Big Apple. Two souls, uptown and downtown, enclosed in a single piece whose fully changeable covers reveal its innate versatility. The unusual and polyhedral ergonomics of the New York armchair encourages a personal use of the covers and the two colours, allowing different colour solutions from a single choice. The frame in iron rod comes in many colour and coating finishes. Fully removable covers.

[FR] – New York est une collection qui porte fièrement le nom de la Grande Pomme. Deux âmes, uptown et downtown, réunies dans un unique objet de design dont le revêtement, entièrement interchangeable, en dévoile la flexibilité innée. L'ergonomie insolite aux multiples facettes du fauteuil New York invite à une utilisation personnelle du revêtement et au bicolore, en permettant différentes solutions chromatiques à partir d'un choix unique. La structure est en fil d'acier disponible en de nombreuses finitions, aussi bien chromées que laquées. Entièrement déhoussable.

[ES] – New York es una colección que lleva con orgullo el nombre de la Gran Manzana. Dos almas, uptown y downtown, integradas en un objeto de diseño único, cuyo tapizado, completamente intercambiable, desvela su innata versatilidad. La ergonomía insólita y poliédrica del sillón New York invita a un uso personal del tapizado y al bicolore, favoreciendo distintas soluciones cromáticas con una elección única. La estructura de barra redonda de hierro está disponible en múltiples acabados cromados y pintados. Completamente desenfundable.

New York Armchair

Poltrone 74x83 cm in tessuto  
tavolino Leyva  
Armchairs 74x83 cm in fabric  
Leyva low table  
Fauteuil 74x83 cm en tissu  
table basses Leyva  
Sillones 74x83 cm de tela  
mesa de centro Leyva







**New York Armchair**

Poltrona 74x83 cm in tessuto  
Armchair 74x83 cm in fabric  
Fauteuil 74x83 cm en tissu  
Sillón 74x83 cm de tela



New York Armchair

Poltrona 74x83 cm in tessuto  
Armchair 74x83 cm in fabric  
Fauteuil 74x83 cm en tissu  
Sillón 74x83 cm de tela

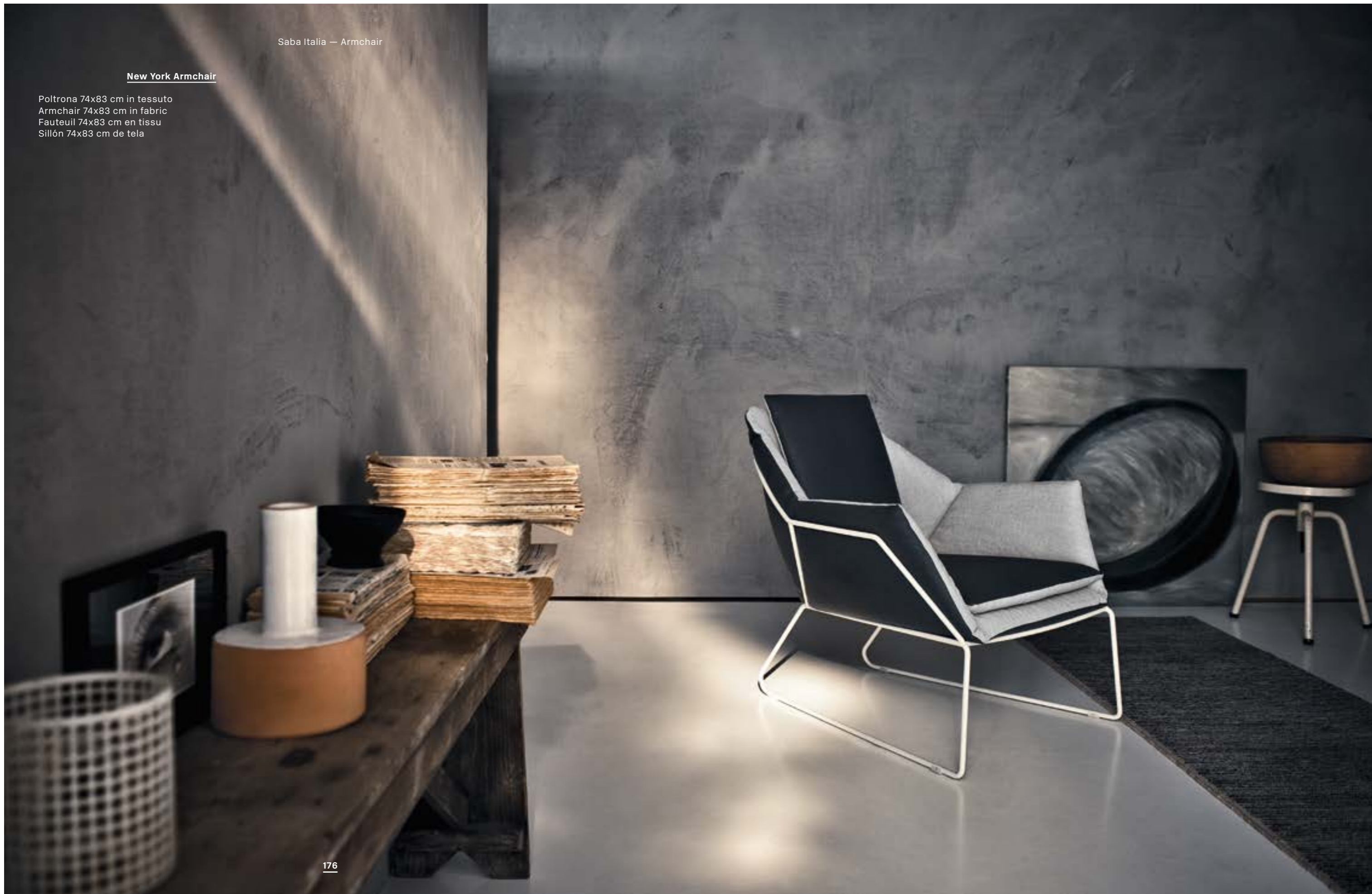

# New York Bergère

**[IT] – La medesima struttura della poltrona New York accoglie la confortevole imbottitura della bergère. La classica funzione della poltrona da lettura o relax è garantita dall'altezza dello schienale, dal comodo poggiatesta e dall'elegante pouf. Un filo continuo con la tradizione interpretato in veste contemporanea con sofisticata leggerezza. Completamente sfoderabile.**

**Technical data**  
— New York Bergère p. 280

**Design Sergio Bicego**  
**Production year 2014**

[EN] – The same frame as the New York armchair boasts the comfortable upholstery of the bergère. The classic function of the armchair for reading or relaxing is ensured by the height of the back, the comfortable headrest and the elegant pouf. An unbroken link with tradition interpreted in a contemporary style with a sophisticated lightness. Fully removable covers.

[FR] – La même structure que le fauteuil New York accueille le confortable rembourrage de la bergère. La fonction classique du fauteuil de lecture ou de repos est garantie par la hauteur du dossier, par le confortable appui-tête et par l'élégant pouf. Un fil continu avec la tradition, interprété sous un jour contemporain avec une légèreté sophistiquée. Entièrement déhoussable.

[ES] – El cómodo relleno acolchado del sillón orejero se replica en la misma estructura del sillón New York. La función clásica del sillón de lectura o descanso está garantizada por la altura del respaldo, el cómodo reposacabezas y el elegante taburete. Un hilo continuo con la tradición interpretado en estilo contemporáneo con sofisticada ligereza. Completamente desenfundable.





## New York Chair

**[IT] – Raffinato complemento per la zona pranzo, la sedia New York con o senza braccioli, si distingue per l'agile struttura e la confortevole imbottitura impreziosita da piccole trapuntature tono su tono. La nuova finitura cromo nero va ad aggiungersi alle versioni cromo lucido e alla verniciatura bianca o nera. Completamente sfoderabile.**

Technical data  
→ New York Chair p. 280

Design Sergio Bicego  
Production year 2014

[EN] – A sophisticated item of furniture for the dining area, the New York chair with or without armrests stands out with its sprightly structure and comfortable upholstery embellished by small tonal quilted parts. The new black chrome finish has been added to the gloss chrome and black or white coating versions. Fully removable covers.

[FR] – Complément raffiné pour la zone déjeuner, la chaise New York avec ou sans accoudoirs, est caractérisée par sa structure fine et par le confortable rembourrage enrichi par de petits matelassages ton sur ton. La nouvelle finition chrome noir vient s'ajouter aux versions chrome brillant et à la finition blanche ou noire. Entièrement déhoussable.

[ES] – Complemento refinado para la zona de comer, la silla New York con o sin brazos se distingue por la ágil estructura y el confortable acolchado, embellecido por respunteados diminutos tono sobre tono. El nuevo acabado cromo negro se añade a las versiones cromo brillo y a la pintura blanca o negra. Completamente desenfundable.



Saba Italia — Armchair

**New York Chair**

Sedia con e senza braccioli  
59x54 cm e 56x54 cm in tessuto  
Chair with or without armrests  
59x54 cm and 56x54 cm in fabric  
Chaise avec ou sans bras  
59x54 cm et 56x54 cm en tissu  
Silla con o sin brazos  
59x54cm y 56x54 cm de tela



# New York Outdoor

[IT] – La poltroncina

**New York Outdoor è il risultato di un'accurata ricerca sui materiali al fine di preservare l'unicità del progetto originale. Si caratterizza per la struttura in tondino di metallo verniciato bianco con trattamento adatto agli ambienti esterni. L'ergonomica cuscineria è rivestita in tessuto tecnico che non assorbe l'acqua, consentendo una rapida asciugatura, inoltre l'alta performance al test martindale fino a 90.000 cicli garantisce resistenza all'abrasione e contemporaneamente una igienica traspirazione. L'imbottitura dei cuscini è in poliuretano drenante rivestita da una fodera bianca impermeabile. New York outdoor interpreta l'arte di vivere l'esterno con poetica leggerezza di stile e suggestioni cromatiche. Completamente sfoderabile.**

Technical data  
→ New York Outdoor p. 282

Design Sergio Bicego  
Production year 2013

[EN] — New York outdoor armchair is the result of careful research into materials so as to preserve the uniqueness of the original design. It features a white-painted tubular metal frame specifically treated for outdoor use. The ergonomic cushion is covered in a quick-drying, non-absorbent technical fabric, and its great performance in the Martindale test, up to 90000 cycles, guarantees abrasion resistance as well as hygienic breathability. The cushions are filled with quick-draining polyurethane, with a waterproof white cover. New York outdoor interprets the art of outdoor living with poetically light style and colourful charm. Fully removable covers.

[FR] — Le fauteuil New York outdoor est le résultat d'une recherche approfondie sur les matériaux afin de préserver le caractère unique du projet original. Il se caractérise par une coque en rond de métal laqué blanc avec traitement adéquat pour résister à l'extérieur. Les coussins ergonomiques sont revêtus d'un tissu technique qui n'absorbe pas l'eau en permettant un séchage rapide. De plus, la haute performance au test Martindale jusqu'à 90 000 cycles garantit la résistance à l'abrasion ainsi qu'une respiration hygiénique. Le rembourrage des coussins est en polyuréthane drainant, revêtu d'une doublure blanche imperméable. New York outdoor interprète l'art de vivre l'extérieur avec une légèreté de style et des suggestions chromatiques à l'enseigne de la poésie. Entièrement déhoussable.

[ES] — La butaca New York outdoor para exteriores es el resultado de una esmerada investigación aplicada a los materiales cuyo objetivo es preservar la unicidad del proyecto original. Se caracteriza por la estructura en varilla de metal pintado de color blanco, con tratamiento apropiado para exteriores. Los cojines ergonómicos están tapizados con tejido técnico que no absorbe el agua y facilita el secado. Además de los excelentes resultados a la prueba de Martindale de hasta 90000 ciclos garantiza resistencia a la abrasión y, a su vez, una transpiración higiénica. El relleno de los cojines es de poliuretano de óptimo drenaje revestido por una funda blanca impermeable. New York outdoor interpreta el arte de vivir al aire libre con poética ligereza de estilo y sugerencias cromáticas. Completamente desenfundable.

New York Outdoor

Poltrone 74x83 cm in tessuto  
Armchairs 74x83 cm in fabric  
Fauteuil 74x83 cm en tissu  
Sillones de 74x83 cm de tela





# Valentine

[IT] – **Una serie di sedute dal gusto informale con contenuti di praticità e comfort elevati. Le forme morbide, ispirate agli anni '70, rendono Valentine versatile senza trascurare il lato estetico-funzionale. Un appeal estremamente "solido", quasi monolitico, cela un'anima inaspettatamente leggera: una delle sue caratteristiche principali risiede infatti nei materiali scelti per le imbottiture che permettono un facile trasporto dei moduli. Completamente sfoderabile.**

Technical data  
→ Valentine p. 282

Design Marzia e Leonardo Dainelli  
Production year 2012

[EN] – A line of seating featuring an informal style, superior comfort and practicality. The soft, 70s-inspired shapes make the Valentine collection versatile while retaining its aesthetic and functional appeal. A very "solid", almost monolithic quality hides an unexpected lightness: one of its great features is the choice of materials for the padding, which makes for easy unit transportation. Fully removable covers.

[FR] – Une série de sièges au goût informel avec des contenus d'une praticité et d'un confort incomparables. Les formes moelleuses, s'inspirant des années 70, assurent la polyvalence de Valentine, sans négliger le côté esthétique et fonctionnel. Son aspect compact, presque monolithique, cache une âme étonnamment légère : l'une de ses principales caractéristiques réside en effet dans les matériaux choisis pour le rembourrage qui permettent un transport aisé des éléments. Entièrement déhoussable.

[ES] – Una serie de asientos de gusto informal, muy prácticos y confortables. Las formas suaves, inspiradas en los setenta, hacen de Valentine un modelo versátil, sin olvidar el lado estético-funcional. Una sólida capacidad de atracción, casi monolítica que esconde un alma inesperadamente ligera: una de sus características principales se focaliza en los materiales usados para los rellenos que facilitan el transporte de los módulos. Completamente desenfundable.





# Bustier

**[IT] – Forme eleganti e sinuose per Bustier, una poltrona che trae ispirazione dai busti avvolgenti delle dame ottocentesche. Bustier si compone di una scocca rigida che abbraccia soffici cuscini in piuma prestando le sue forme a innumerevoli cambi d'abito e interpretazioni. La collezione tessuti di Saba Italia, unica nel suo genere, interpreta in modo eclettico Bustier per arredare, decorando, sia zone living che contract. Completamente sfoderabile.**

Technical data  
→ Bustier p. 282

Design Giuseppe Viganò  
Production year 2010

[EN] — Bustier's elegant, curvy shape was inspired by the body-hugging corsets worn by ladies in the 19th century. Its rigid shell embraces soft feather cushions, and its shape means you can adapt it to many different covers and uses. The unique Saba Italia fabric collection offers an eclectic selection of Bustier covers for residential or contract furnishing. Fully removable covers.

[FR] — Formes élégantes et sinueuses pour Bustier, un canapé qui s'inspire des corsés enveloppants des femmes du XIXe siècle. Bustier se compose d'une coque rigide qui enserme des coussins moelleux en plume, en prêtant ses formes à d'innombrables habillages et interprétations différentes. La collection des tissus Saba Italia, unique en son genre, interprète Bustier avec éclectisme pour meubler, tout en décorant, aussi bien les livings domestiques que les espaces collectifs. Entièrement déhoussable.

[ES] — Formas elegantes y sinuosas para Bustier, un sofá que se inspira en los corsés envolventes de las damas del Ochocientos. Bustier se compone de una estructura rígida que abraza mullidos cojines de pluma, que prestan sus formas a innumerables cambios de tapicería e interpretaciones. La colección de tejidos de Saba Italia es única en su género e interpreta el espíritu de Bustier en modo ecléctico, para amueblar decorando tanto las zonas de estar como los espacios comunitarios. Completamente desenfundable.

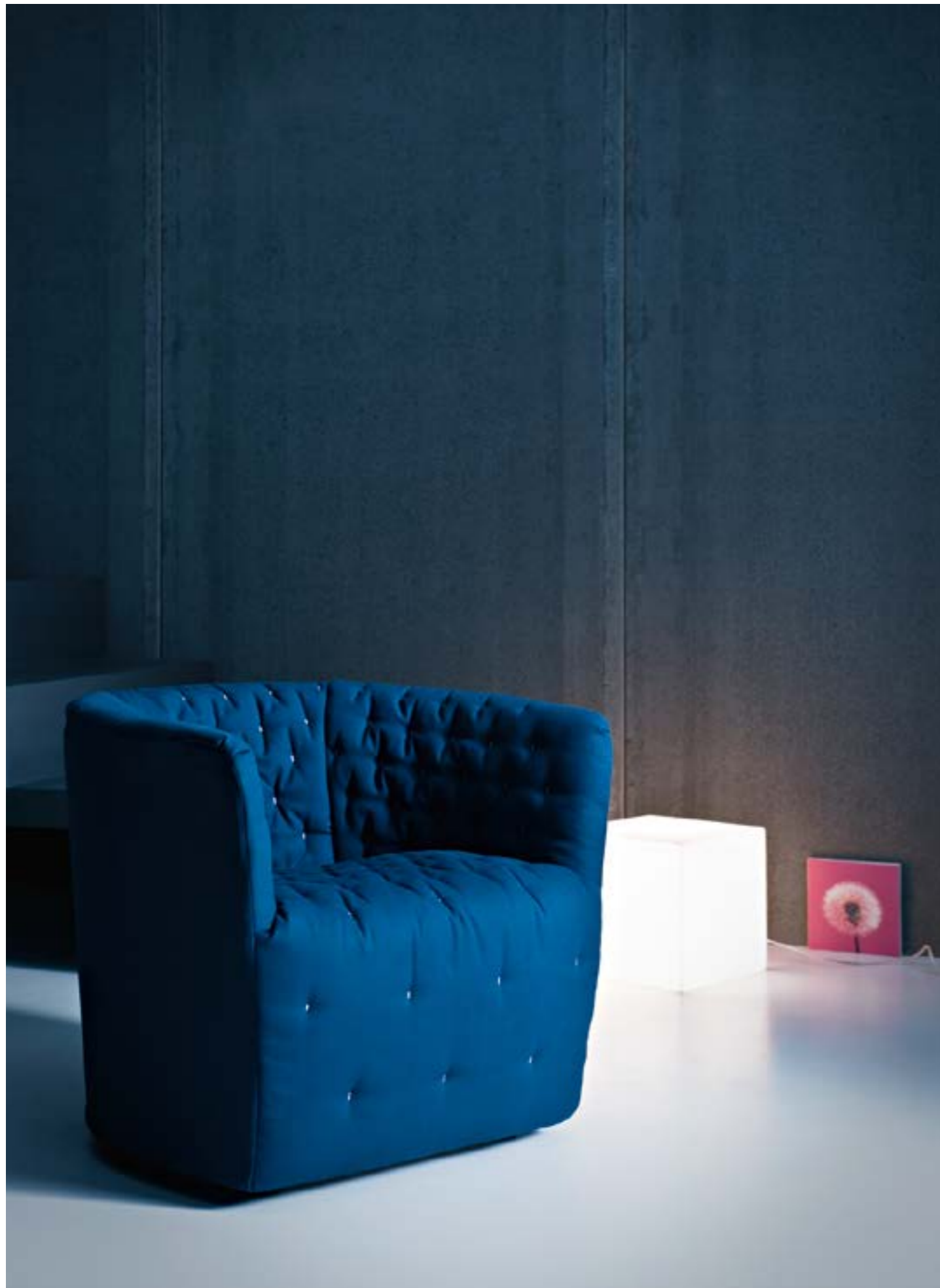

# Amélie

[IT] – **Deliziosa e aggraziata, la poltroncina Amélie rimanda all'haute couture francese. La particolare trapuntatura che sottolinea le curve interne è realizzata a mano seguendo uno schema non casuale. Contenuta ma di forte appeal, si presta ad arredare qualsiasi spazio in cui ci sia l'esigenza di una seduta. Le cuciture trapuntate possono a scelta essere commissionate a contrasto, in un gioco di personalizzazione infinito. Colore su colore per Amélie: le nuances di tendenza ne esaltano le forme sinuose. Disponibile anche con base girevole, completamente sfoderabile.**

Technical data  
→ Amélie p. 283

Design Sergio Bicego  
Production year 2012

[EN] – Delightfully pretty, the Amélie tub chair conjures up visions of French haute couture. The inner curves have been deliberately emphasised by a clever hand-quilted patterning effect. Compact yet with a strong appeal, Amélie would be an attractive addition to any space where seating is required. Customers can choose to order the quilted stitching in a contrasting colour, offering endless possibilities to suit personal choice. Tone-on-tone for Amélie: the latest hues give prominence to its graceful lines. Also available with a swivel base, fully removable covers.

[FR] – Gracieux et raffiné, le fauteuil Amélie renvoie à la haute couture française. Son matelassage qui en souligne les courbes internes est réalisé à la main suivant un schéma précis. De dimensions contenues mais doté d'un grand charme, il s'adapte à n'importe quel espace. Les coutures du matelassage peuvent être commandées au choix dans une couleur contrastante permettant ainsi une personnalisation infinie. Ton sur ton pour Amélie : les nuances tendance en exaltent les formes sinueuses. Disponible également avec pied pivotant, entièrement déhoussable.

[ES] – Deliciosa y agraciada, la butaca Amélie evoca la alta costura francesa. El pespunteado particular que remarca las curvas internas se realiza a mano siguiendo un esquema definido. De pequeñas dimensiones pero muy atractivo, es ideal para decorar cualquier espacio que presente la exigencia de un asiento. Las costuras pespunteadas pueden realizarse en contraste, con un infinito juego de personalizaciones. Color sobre color para Amélie: las tonalidades de tendencia exaltan las formas sinuosas. Disponible también con base giratoria, totalmente desenfundable.

Amélie

Poltrone 73x66 cm in tessuto  
tavolini A song for you  
Armchairs 73x66 cm in fabric  
A song for you low tables  
Fauteuil 73x66 cm en tissu  
tables basse A song for you  
Sillones de 73x66 cm de tela  
mesas de centro A song for you



# Chance

[IT] — **Chance è una poltroncina girevole dalle dimensioni contenute, adatta a prestarsi come elemento funzionale-decorativo in ogni contesto abitativo e contract. Una forma senza tempo, la cui anima si rivela di volta in volta attraverso l'abito di cui si riveste. Completamente sfoderabile.**

Technical data  
— Chance p. 283

Design Sergio Bicego  
Production year 2003

[EN] — Chance is a compact swivelling tub chair, equally functional and decorative in both domestic and contract settings. Its timeless shape reveals its myriad souls depending on the chosen coverings. Fully removable covers.

[FR] — Chance est un fauteuil pivotant aux dimensions contenues, qui peut devenir un élément fonctionnel et décoratif dans n'importe quel contexte, privé ou public. Une forme atemporelle, dont l'âme se révèle à chaque fois différente, suivant l'habit qu'on veut lui donner. Entièrement déhoussable.

[ES] — Chance es una butaca giratoria de dimensiones no excesivas, apta para convertirse en un elemento funcional y decorativo en cualquier espacio residencial y colectivo. Una forma atemporal, cuya alma se desvela a través de los tapizados con los que se recubre. Completamente desfundable.





## No logo light

**[IT] – La doppia anima, maschile e femminile al tempo stesso, di No logo light consente a questa poltrona di convivere sia nelle case più familiari ed accoglienti che negli spazi pubblici rigorosi. In particolare risalto il contrasto tra l'austerità della struttura in acciaio nichelato e la sorprendente comodità delle sedute in piuma d'oca. Prodotta a partire dal 2005, No logo light si pone con carattere al centro del vivere quotidiano, senza creare disturbo ma facendosi sempre notare. Completamente sfoderabile.**

Technical data  
→ No logo light p. 283

Design Sergio Bicego  
Production year 2005  
Restyling 2012

[EN] – No logo light features a dual soul, both masculine and feminine, which enables this collection of two- and three-seater sofas and a comfortable armchair to fit equally seamlessly into the cosiest of family homes and into the most rigorous of public spaces. Its most striking features are the austerity of the nicked steel frame and the unexpectedly comfortable goose-down filled seat cushions. In production since 2005, No logo light places itself squarely at the centre of everyday life, always drawing attention to itself, yet with the utmost discretion. Fully removable covers.

[FR] – La double âme, à la fois masculine et féminine, de No logo light permet à cette collection, faite de canapés à deux et trois places et d'un confortable fauteuil, de s'intégrer dans les espaces privés, imprégnés de chaleur domestique, tout comme dans les espaces publics les plus exigeants. Elle met l'accent en particulier sur le contraste entre l'austérité de la structure en acier nickelé et le confort surprenant des assises garnies de plumes d'oie. Produite depuis 2005, la collection No logo light s'impose avec caractère au cœur de notre quotidien, se faisant toujours remarquer mais sans intrusion aucune. Entièrement déhoussable.

[ES] – La doble alma, simultáneamente masculina y femenina de No logo light permite que esta colección, compuesta por sofás de dos y tres plazas y por un cómodo sillón, pueda convivir en las casas de familia más acogedoras y en los espacios públicos rigurosos. Resalta particularmente el contraste entre la austeridad de la estructura de acero niquelado y la sorprendente comodidad de los asientos de pluma de ganso. Se fabrica desde 2005. No logo light impone su carácter y se pone al centro del vivir cotidiano, sin molestar pero haciéndose notar siempre. Completamente desenfundable.

# Livingston

**[IT] – La poltroncina Livingston è il giusto complemento all'omonimo divano. Precisa nelle proporzioni, rientra tra gli oggetti che non risentono delle insidie della moda. La struttura in acciaio ben si accosta ai rivestimenti sia in pelle sia in tessuto. Completamente sfoderabile.**

Technical data  
→ Livingston p. 284

Design Giuseppe Viganò  
Production year 2009

[EN] – The Livingstone tub chair is the perfect companion to the Livingstone sofa. With its balanced proportions, it is one of those objects whose beauty never fades. Its steel frame perfectly matches both leather and fabric upholstery. Fully removable covers.

[FR] – Le siège Livingston constitue le parfait complément du canapé éponyme. Aux proportions bien pensées, il fait partie des objets qui font fi du temps et des modes passagères. Sa structure en acier est véritablement sublimée par les revêtements proposés, cuir ou tissu. Entièrement déhoussable.

[ES] – El sillón Livingston es el complemento ideal del sofá homónimo. Con sus proporciones precisas, es uno de esos objetos que no se ven influidos por las modas. La estructura de acero se combina perfectamente con los revestimientos de piel o de tejido. Totalmente desenfundable.





## Essentiel

**[IT] – La poltrona Essentiel si presenta con una precisa dichiarazione di intenti: un progetto privo di eccessi, dall'ergonomia accogliente, che nella mappa spazio-temporale del design congiunge idealmente l'eleganza storica italiana al tratto nordico. Essenziale nella linea, ma duttile nella personalizzazione, può essere arricchita da un cuscino arredo rettangolare o quadrato con dettaglio bottone. La sua allure sofisticata viene esaltata dal particolare piedino verniciato corten e dalla profilatura in cordino di canetè a scelta nelle varianti grigio e corda. Completamente sfoderabile.**

Technical data  
→ Essentiel p. 284

Design Sergio Bicego  
Production year 2016

[EN] – The Essentiel armchair was born with a clear mission: uncluttered, soft and welcoming, in design terms it magnificently fuses clean Scandinavian lines with traditional Italian flair. It has a clean-cut silhouette, yet it is easy to personalise by adding a rectangular or square throw cushion with a button detail. Its sophisticated allure is accentuated with an original Corten varnish foot and a grosgrain cord trim, available either in grey or rope. Fully removable covers.

[FR] – Le fauteuil Essentiel se présente comme une déclaration d'intention sans détours : une proposition dépourvue d'excès, à l'ergonomie accueillante, qui à travers l'espace spatio-temporel du design conjugue idéalement la tradition d'élégance à l'italienne traditionnelle à la solidité nordique. Essentiel est également une ligne qui sait se faire adaptable, il peut être sublimé par un coussin d'ornement rectangulaire ou carré avec détail bouton. Son allure sophistiquée est exaltée en particulier par la densité de la surpiqûre en version gris ou corde et le piètement en Corten patiné laqué. Entièrement déhoussable.

[ES] – El sillón Essentiel se presenta con una declaración de intenciones precisa: un proyecto sin excesos, de ergonomía acogedora, que en el mapa espacial-temporal del diseño une idealmente la histórica elegancia italiana al rasgo nórdico. Esencial en la línea pero dúctil en la personalización, se puede enriquecer con un cojín decorativo rectangular o cuadrado con detalle de botón. Su aspecto sofisticado es exaltado por el particular pie pintado corten y el perfilado en hilo de canetè a elección en las variantes gris y cuerda. Totalmente desfundable.



X W

# Manta

**[IT] – Colpiscono della poltroncina Manta la leggerezza e l'estrema versatilità che i rivestimenti e le finiture realizzate con particolari ricami possono consentire. Manta interpreta con gusto sia vestiti dal forte impatto cromatico come il bicolore che la raffinatezza del tono su tono. Struttura metallica sagomata imbottita con poliuretano espanso. Base laccata bianca o cromata. Completamente sfoderabile.**

Technical data  
→ Manta p. 284

Design Giuseppe Viganò  
Production year 2008

[EN] – What strikes you about the Manta chair is the lightness and extreme versatility of its upholstery and specially embroidered finishes. Manta looks equally good with colourfully stunning two-tone or sophisticated tone-on-tone upholstery. The shaped metal frame is padded with polyurethane foam, covered with Velfodera bonded to 100% polyester fibre. The shaped metal-tube base may be painted white or chrome-plated. Fully removable covers.

[FR] – Le fauteuil Manta frappe par sa légèreté et la grande adaptabilité rendue possible par des propositions de revêtements et de finitions avec broderies. Manta interprète avec goût aussi bien des habillages à grand impact chromatique, comme le bicolore, que le raffinement du ton sur ton. Structure métallique rembourrée de mousse de polyuréthane revêtue d'une doublure associée à de la fibre 100 % polyester. Pied laqué blanc ou chromé. Entièrement déhoussable.

[ES] – De la butaca Manta asombran la ligereza y la enorme versatilidad de la tapicería, así como los acabados realizados con bordados particulares. Manta interpreta con gusto la tapicería de fuerte impacto cromático, la propuesta bicolor y la elegancia del tono sobre tono. Estructura metálica curvada rellena con espuma de poliuretano revestida con funda laminada con fibra de poliéster 100%. Base de varilla redonda perfilada, lacada de color blanco o cromada. Completamente desenfundable.



# LaCarmen

[IT] — **Forza espressiva dal look anticonformista. LaCarmen si esprime nell'insolito "colletto" che si può rialzare grazie a un innovativo materiale autoportante. Il pensiero che alimenta l'idea del progetto sta nel duplice utilizzo della poltrona: un piccolo nido avvolgente, intimo e raccolto con il bavero rialzato; informale e disponibile a spazi conviviali nella posizione base. Struttura in multistrato di faggio rivestito con poliuretano espanso. Schienale in acciaio sagomato ricoperto da poliuretano espanso. Poggiatesta in resinato e colletto dotato di lampo divisibile. Completamente sfoderabile.**

Design Giuseppe Viganò  
Production year 2007

[EN] — The expressive power of LaCarmen's unconventional look is evident from its unusual "collar" which can also be positioned vertically by means of innovative, self-supporting material. The concept underlying the design is that of a dual-purpose chair. With its collar up it is a snug, enveloping nest; with the collar down it has an informal look ideal for convivial settings. Beech plywood frame covered with polyurethane foam. Shaped steel back covered with polyurethane foam. Resin-treated headrest and detachable zipped collar. Fully removable covers.

[FR] — La force expressive au look anticonformiste de LaCarmen s'exprime dans son « col » insolite qui peut se relever grâce à un matériau innovant autoporteur. L'idée à la base du projet réside dans la double utilisation du fauteuil : un petit nid enveloppant, intime et douillet, quand le col est relevé ; informel et disponible pour des échanges conviviaux dans la position de base. Structure en multiples de hêtre revêtu de mousse de polyuréthane. Dossier en acier courbé recouvert de mousse de polyuréthane. Appuie-tête en matériau résiné et col avec zip divisible. Entièrement déhoussable.

[ES] — Fuerza expresiva con un estilo anticonformista: LaCarmen se caracteriza por el insólito "cuello" que se puede subir gracias a un innovador material autoportante. La idea que alimenta el proyecto se basa en el doble uso del sillón: un pequeño nido envolvente, íntimo y acogedor con la solapa levantada; informal y disponible para los espacios comunes en su posición de base. Estructura en estratificado de haya revestida con espuma de poliuretano. Respaldo de acero perfilado, recubierto por espuma de poliuretano. Reposacabeza en material resinado y cuello completo con una cremallera separable. Completamente desenfundable.

Technical data  
— LaCarmen p. 285





## Prêt-à-porter

[IT] – Poltroncina adatta sia agli ambienti classici che informali, dalle proporzioni contenute e rigorose. Fusto in legno imbottito con poliuretano a densità differenziata. Completamente sfoderabile.

Design Sergio Bicego  
Production year 2001  
Restyling 2007

[EN] – An armchair which lends itself to both classic and casual styles, characterized by precise, compact proportions. The wooden frame is padded with variable-density polyurethane. Fully removable covers.

[FR] – Fauteuil aux proportions contenues et rigoureuses, adapté aux décors classiques ou informels. Structure en bois avec rembourrage en mousse polyuréthane de densité variable. Entièrement déhoussable.

[ES] – Butaca apta para los espacios clásicos e informales, de proporciones reducidas y severas. Cuerpo de madera relleno de poliuretano de densidad diferenciada. Completamente desenfundable.

Technical data  
→ Prêt-à-porter p. 285

# Sitar

**[IT] – Poltroncina dalla forma lieve che ricorda l'accoglienza di una piuma, una carezza, una parentesi di armonia realizzata in frassino e cordino di cuoio intrecciato. Il nome ha origini persiane "seh-tar" letteralmente significa tre corde e trova fonte di ispirazione nello strumento della musica classica indiana più conosciuto in Occidente. Un background lontano per un appeal senza tempo e un design contemporaneo. Disponibile in 2 varianti: sbiancato e miele.**

Technical data  
— Sitar p. 285

Design Enzo Berti  
Production year 2006

[EN] — A light armchair that brings to mind the softness of a feather, a caress, a moment of harmony in ash and woven leather cord. The name has Persian origins: "seh-tar" literally means three strings, and the model is inspired by that most famous of Indian classical instruments. Faraway origins that generate timeless appeal for this modern design. Available in two versions: blanched and honey.

[FR] — Fauteuil au cadre léger qui évoque la douceur d'une plume, une caresse, une parenthèse d'harmonie réalisée en frêne et cordelette de cuir tressé. Le nom est d'origine persane, « seh-tar » signifiant littéralement trois cordes et trouve une source d'inspiration dans l'instrument de musique classique indienne le plus célèbre en Occident. Une culture lointaine au service d'un charme éternel et d'un design contemporain. Disponible en 2 variantes : blanchi et miel.

[ES] — Butaca de forma etérea y acogedora como una pluma, una caricia, una paréntesis de armonía realizada en fresno y cuerda de cuero trenzado. El nombre es de origen persa "seh-tar" y literalmente significa "tres cuerdas" y se inspira al instrumento de música clásica india más conocido en Occidente. Un recuerdo lejano para una fascinación sin tiempo y un diseño contemporáneo. Disponible en dos variantes: blanqueado y miel.





## Bed & Breakfast

**[IT] – Bed & Breakfast è un divano che permette con un semplice movimento di ribaltare lo schienale e trasformarlo in un confortevole letto. La facilità di apertura del divano-letto è resa possibile dalla presenza di un taglio rettangolare sottostante la base e dalla particolare struttura della rete che, scorrendo orizzontalmente grazie a un meccanismo di incastro a pettine, crea un allungamento dello spazio d'appoggio. Bed & Breakfast è composto dal Divano-letto matrimoniale e la Chaise Longue-letto singolo. I maxi cuscini da appoggio possono fungere da piccola trapunta quando utilizzati nella loro interezza, una volta piegati e chiusi dai due alamari in legno garantiscono invece un'ottima ergonomia come schienale.**

Technical data  
→ Bed & Breakfast p. 286

Design Giuseppe Viganò  
Production year 2011

[EN] – Bed & Breakfast is a sofa which transforms into a comfortable bed simply by folding down the backrest. The sofa bed is easy to open, thanks to a rectangular hole cut into the underside of the base, and to the special structure of the boxspring, which runs horizontally on a finger-jointed mechanism to create the extra length needed. Bed and Breakfast ranges are comprised of the Sofa-double bed and the Chaise Longue-single bed. This is the result of advanced research into new-generation materials which give maximum comfort with optimum resilience. The maxi scatter cushions unfold to create a small quilt, and can then be refolded and fastened with two wooden frog buttons, to offer excellent back support.

[FR] – Bed & Breakfast est un canapé convertible qui permet, d'un simple mouvement, de rabattre le dossier et de le transformer en un lit confortable. La facilité d'ouverture du convertible est rendue possible par la présence d'une découpe rectangulaire sous la base et par la structure particulière du sommier qui, en coulissant horizontalement, grâce à un mécanisme articulé, permet d'allonger le plan d'appui. Bed & Breakfast est composé de deux éléments : le canapé - lit double et la chaise longue - lit individuel. Les maxi-coussins peuvent se transformer en petits édredons quand il sont ouverts, tandis que repliés et fermés par les deux brandebourgs en bois, ils garantissent une excellente ergonomie du dossier.

[ES] – Bed & Breakfast es un sofá cama que permite voltear el respaldo y transformar el sofá en una cama confortable con un simple movimiento. La apertura del sofá es facilitada por la presencia de una hendidura rectangular debajo de la base, y por la estructura particular del somier que, deslizándose horizontalmente gracias a un mecanismo de encastre a peine, crea un alargamiento del espacio de apoyo. Bed & Breakfast se compone de sofá-cama matrimonial y chaise longue-cama individual. Cuando se usan en su totalidad, los maxicojines de apoyo pueden usarse como un edredón; en cambio, cuando se doblan y cierran con los dos alamares de madera, garantizan una óptima ergonomía como respaldo.

**Bed & Breakfast**

Composizione 305x165 cm in tessuto  
tavolino Silver ring  
Composition 305x165 cm in fabric  
Silver Ring low table  
Composition 305x165 cm en tissu  
table basse Silver ring  
Composición 305x165 cm de tela  
mesa de centro Silver ring





**Bed & Breakfast**

Divano 200x105 cm in tessuto  
poltrona Sitar, tavolino Leyva  
Sofa 200x105 cm in fabric  
Sitar armchair, Leyva low table  
Canapé 200x105 cm en tissu  
fauteuil Sitar, table basse Leyva  
Sofá 200x105 cm de tela  
sillón Sitar, mesa de centro Leyva





## A song for you

**[IT] – Un piccolo complemento che, grazie alla presenza di due fori sul piano e alla duplice altezza, diventa un modulo compositivo aggregabile all'infinito. Ogni tavolino ha una propria autonomia formale e funzionale e può essere utilizzato singolarmente. Più tavolini possono dare vita a una sinfonia di forme per composizioni più complesse e utilizzi inediti. Grazie alla possibilità di accogliere sul piano d'appoggio un cuscino di seduta appositamente studiato, si presta per arredare in modo creativo la zona living così come le aree contract. Realizzato con gambe in massello di faggio naturale e piano in mdf laccato bianco o con piano in multistrato di legno zebrano impiallacciato naturale, A song for you diventa una presenza discreta nell'ambiente. L'aggiunta di cuscini colorati ne aumenta la personalità e la forza visiva.**

Technical data  
→ A song for you p. 287

Design Paolo Grasselli  
Production year 2012

[EN] – Thanks to two holes in the top and two different heights, this small accessory becomes a compositional unit that can be configured in endless ways. Each table is functionally independent and can be used separately. By combining two or more tables, you can create a symphony of shapes, giving rise to more complex compositions and new uses. And by placing a specifically designed cushion on the table top, this new table can also provide seating, offering a creative way of decorating the living area as well as contract areas. With legs made of solid beech wood and top available in white lacquered MDF or natural zebrano veneer plywood, A song for you discreetly blends in with the environment. The addition of colourful cushions enhances its personality and visual appeal.

[FR] – Il est ainsi possible de séparer des bases les accoudoirs et les dossiers pour créer de nouvelles compositions en toute liberté. Les assises garnies de plumes sont caractérisées par un matelassage qui se prête à toute les nombreuses combinaisons possibles entre les tissus de la collection Saba, pour créer à chaque fois un canapé unique et très personnel. Grâce à la forme particulière des dossiers et des accoudoirs, les dimensions générales du canapé sont toujours très compactes, aussi bien en largeur qu'en profondeur, sans en pénaliser l'esthétique. Le canapé Pixel a été soigneusement conçu suivant les critères d'ergonomie, pour assurer le plus grand confort à un produit très recherché pour son style. Entièrement déhoussable.

[ES] – Un pequeño complemento que se convierte en un módulo de composición que puede adosarse al infinito gracias a la presencia de dos agujeros en el plano y a la doble altura. Cada mesa de centro es autónoma desde el punto de vista formal y funcional y puede utilizarse individualmente. Varias mesas de centro pueden crear una sinfonía de formas para lograr composiciones más complejas y usos inéditos. Ofrece la posibilidad de apoyar sobre la tapa un cojín para sentarse específicamente estudiado; es ideal para decorar con creatividad la zona de estar y las áreas colectivas. Realizada con patas de madera maciza de haya natural y tapa de MDF lacado blanco, o con tapa en estratificado de madera zingana contrachapado natural, A song for you se convierte en una presencia discreta en la habitación. El añadido de los cojines coloreados aumenta la personalidad y la fuerza visual.

Saba Italia — Low table

A song for you

Tavolini 75x50 cm in MDF e tessuto  
Low tables 75x50 cm in MDF and fabric  
Tables basses 75x50 MDF et tissu  
Mesas de centro 75x50 cm en MDF y tela







# Haiku

**[IT] – Haiku è il termine giapponese che descrive un componimento poetico costituito da soli tre versi per un totale di diciassette sillabe. Il nuovo coffee table firmato Marco Zito per Saba Italia si compone appunto di tre elementi: la struttura e i due piani. L'esile architettura sospende i piani su due livelli che giocano sulla parziale sovrapposizione e su accostamenti di colore dalle nuances pastello, in un semplice e misurato rapporto di equilibrio e proporzioni. Haiku è stato pensato in una palette raffinata che gioca su lievi sfumature: Cipria / Rosa antico; Verde lichene / Verde militare; Tortora / Cipria; Grigio / Azzurro Irlanda. Struttura in tondino metallico verniciato nero opaco. Piani in Mdf laccato.**

Technical data  
→ Haiku p. 287

Design Marco Zito  
Production year 2014

[EN] – Haiku is a Japanese word used to describe a poem consisting of just three lines up to a total of seventeen syllables. The new coffee table designed by Marco Zito for Saba Italia is in fact made up of three parts – the frame and the two tops. The slim architecture suspends the tops on two levels which play with the partial overlap and combinations of colours in pastel shades, in a simple and well-gauged relationship of balance and proportions. Haiku was designed with a sophisticated palette which plays on subtle shading: Mud cream / Old Rose; Moss green / Military Green; Taupe / Mud cream; Grey / Irish Blue.

[FR] – Haïku est le terme japonais qui décrit un poème constitué de seulement trois vers pour un total de dix-sept syllabes. La nouvelle table basse signée Marco Zito pour Saba Italia se compose justement de trois éléments : la structure et les deux plateaux. Cette architecture fine suspend les plateaux sur deux niveaux, jouant sur la superposition partielle et sur des rapprochements de couleurs aux nuances pastel, dans un rapport d'équilibre et de proportions simple et bien dosé. Haïku a été pensé dans une palette raffinée qui joue sur des nuances légères : Rose chair / Vieux rose ; Vert lichen / Vert khaki ; Tourterelle / Rose chair ; Gris / Blue irlandais. Structure en rond de métal laqué noir mat. Plateaux en MDF laqué.

[ES] – Haiku es el término japonés que describe una composición poética formada solo por tres versos, hasta llegar a un total de diecisiete sílabas. La nueva mesita de café firmada Marco Zito para Saba Italia se compone precisamente por tres elementos: la estructura y los dos tableros. La arquitectura delicada suspende los tableros en dos niveles que juegan en la superposición parcial y en las combinaciones de color de tonos pastel, en una relación simple y mesurada de equilibrio y proporciones. Haiku ha sido ideada en una refinada paleta de colores que juega con leves matices. Maquillaje / Rosa antiguo; Verde líquen / Verde militar; Gris ceniciento / Maquillaje; Gris / Azul Irlanda. Estructura de varilla redonda metálica pintada negro mate. Tableros de MDF lacado.

Haiku

Tavolini, paraventi Shade  
Low tables, Shade dividers  
Tables basses, paravents Shade  
Mesas de centro, biombos Shade





# Leyva

[IT] – **Tavolino dalla struttura  
“a griglia” in tondino di ferro  
verniciato e saldato a quadri regolari,  
s sofisticato e poco invasivo  
alla vista, decora il living room  
con un tocco di leggerezza  
e contemporaneità. Disponibile  
nelle varianti bianco e nero.**

**Design Giuseppe Viganò  
Production year 2007**

[EN] – The Leyva table is made of painted iron rods welded into a grille of uniform squares. Sophisticated and non-intrusive, Leyva decorates the living room with a light, contemporary touch. Available in black or white.

[FR] – Table basse structurée à partir d'une armature en acier soudée et vernie. Sophistiquée et peu envahissante, elle décore le living avec une touche de légèreté et de modernité. Disponible en blanc et en noir.

[ES] – Mesa de centro con estructura a rejilla, en varilla de hierro pintado y soldado formando cuadrados regulares, sofisticado y algo impactante a la vista, decora la sala de estar con un toque de levedad y contemporaneidad. Disponible en las variantes blanco y negro.

**Technical data  
→ Leyva p. 288**



## Più Table

[IT] – **Tavolino leggero e stilisticamente definito, dal design netto e deciso ma dall'anima elegante e delicata. Materiale: base in acciaio e piano in MDF. È disponibile con finitura laccata opaca nelle varianti colore: bianco, nero, bronzo, rosso e argento. Realizzabile su richiesta in tutti i colori RAL.**

Technical data  
→ Più Table p. 288

Design Giuseppe Viganò  
Production year 2009

[EN] – A light, crisp and stylish table with a strong, clean design and an elegant, dainty spirit. Material: steel base, MDF top. Available in a gloss matt lacquered finish in the following colours: white, black, bronze, red and silver. Available in all RAL colours on request.

[FR] – Table basse légère au style bien défini. Design net et franc au service d'une âme élégante et délicate. Matériau : base en acier et plateau en MDF. Disponible en finition laquée mate dans les coloris suivants : blanc, noir, bronze, rouge et argent. Réalisable sur demande dans toutes les couleurs RAL.

[ES] – Mesa de centro ligera y con personalidad estilística definida, de diseño neto y determinado pero con alma elegante y delicada. Material: base de acero y tapa de MDF. Está disponible con acabado lacado mate en las variantes de color: blanco, negro, bronce, rojo y plata. Realizada bajo demanda en todos los colores RAL.



## Ziggy / Ziggy XL

**[IT] – Ferro, legno, corda: materiali semplici che reinventano oggetti di uso comune. Una collezione di pouf e tavolini in tondino di ferro e intreccio di cime in Poliestere HT tinto in pasta, si mescolano come in una tavolozza di pittore. Le silhouettes a botte e a clessidra s'incontrano per comporre isole che si espandono: intrecci e volumi si perfezionano negli abbinamenti delle tonalità mixate delle cime, indicando una nuova idea di complemento con una possibilità illimitata di personalizzazione dello spazio. La corda intrecciata a due colori è una combinazione esclusiva Saba. Il pouf (botte e clessidra) è realizzato con materiali adatti all'uso esterno. La collezione Ziggy si completa di un nuovo elemento: il tavolino Ziggy XL realizzato con materiali adatti all'esterno: piano in marmo, Thala beige chiaro. Dimensioni top in marmo: 70 cm; piano inferiore 90 cm; altezza 37 cm.**

Technical data  
— Ziggy p. 289

Design Emilio Nanni  
Production year 2014/2016

**[EN] — Iron, wood, rope - simple materials which reinvent commonly used objects. A collection of poufs and coffee tables made of iron rods and woven cables in paste-dyed HT polyester, mixed together like the paints on an artist's palette. The barrel and hourglass silhouettes come together to make up islands which expand: interweaving and volumes are enhanced in the coordination of the mixed colours of the cord, pointing to a new idea of furnishing accessory with endless possibilities of personalising the space. The two-tone plaited rope is an exclusive Saba combination. The pouf (hourglass and barrel) has been made with materials suitable for outdoor use. A new piece has been added to the Ziggy collection: the Ziggy XL low table. It is suitable for outdoor use: light Thala beige marble top. Size marble top: 70 cm; lower shelf: 90 cm; full height 37 cm.**

**[FR] — Fer, bois, corde, des matériaux simples pour réinventer les objets d'usage courant. Une collection de poufs et de tables basses en tressage métallique de cordes en Polyester HT teinté dans la masse, pour se fondre comme sur la palette d'un peintre. Les silhouettes en tonneau et en sablier se rencontrent pour composer des îlots en expansion : les tressages et les volumes se perfectionnent dans les rapprochements des teintes mélangées des cordages, en proposant un nouveau concept du mobilier d'appoint pour une personnalisation de l'espace. Le cordage tressé bicolore est une combinaison exclusive signée Saba. Le pouf (coloris tonneau et clessidra) est réalisé en matériaux traités spécialement pour l'extérieur. La collection Ziggy accueille un nouveau accessoire : la table basse Ziggy XL réalisée à partir de matériaux adaptés aux espaces extérieurs : plateau en marbre Thala beige clair. Dimensions : partie supérieure en marbre : 70 cm ; plateau inférieur : 90 cm ; hauteur 37 cm.**

**[ES] — Hierro, madera, cuerda, materiales simples que reinventan objetos de uso común. Una colección de taburetes bajos y mesas de centro en varillas redondas de hierro y cabos trenzados de poliéster HT teñidos en pasta, se mezclan como en una paleta de pintor. Las siluetas tipo barril y clessidra se reúnen para componer islas expansibles: asociaciones y volúmenes que se perfeccionan en las combinaciones de tonalidades mezcladas de los cabos, indicando una nueva idea de complemento con una posibilidad ilimitada de personalización del espacio. La cuerda trenzada de dos colores es una combinación exclusiva de Saba. El puf (barril y clessidra) está realizado con materiales adecuados para el uso en exteriores. La colección Ziggy XL se completa con un nuevo elemento : la mesa de centro Ziggy XL realizada con materiales adecuados para exteriores: encimera de mármol Thala beige claro. Medidas: encimera de mármol: 70 cm; superficie inferior: 90 cm; altura total : 37 cm**

Saba Italia — Low table

Ziggy

Tavolini, pouf  
Low tables, pouf  
Tables basses, pouf  
Mesas de centro, puf





Ziggy

Tavolini, pouf  
Low tables, pouf  
Tables basses, pouf  
Mesas de centro, puf





## Foulard / Foulard-ino

**[IT] – Foulard. Un doppio ripiano di legno, con basamento in metallo e colonna portante in legno gioca con la leggerezza di un foulard mosso dal vento. È disponibile con finitura laccata opaca nelle varianti colore bianco e nero. Realizzabile su richiesta in tutti i colori RAL. Foulard-ino. Piccolo e raffinato, è costituito da un doppio ripiano di MDF laccato con basamento in metallo e una doppia colonna portante in MDF sagomato. È disponibile con finitura laccata opaca nelle varianti colore bianco e nero. Realizzabile su richiesta in tutti i colori RAL.**

**Design Giuseppe Viganò  
Production year 2008/2009**

[EN] – Foulard is a table made of two wooden shelves, a metal base and a wooden stand. It brings to mind the lightness of a headscarf blowing in the wind. Available in a matt lacquered finish in black and white. Available in all RAL colours on request. Foulard-ino. Small and sophisticated, it features two lacquered MDF shelves, a metal base and a double, shaped MDF stand. Available in a matt lacquered finish in black and white. Available in all RAL colours on request.

[FR] – Foulard. Un double plateau en bois, avec base en métal et colonne portante en bois joue avec la légèreté d'un foulard bougé par le vent. Disponible en finition laquée mate en blanc et noir. Réalisable sur demande dans toutes les couleurs RAL. Foulard-ino. Petite table raffinée, constituée d'un double plateau en MDF laqué avec base en métal et une double colonne portante en MDF galbé. Disponible en finition laquée mate en blanc et noir. Réalisable sur demande dans toutes les couleurs RAL.

[ES] – Foulard. Un estante doble de madera, con base de metal y columna portante de madera, que juega con la ligereza de un pañuelo acariciado por el viento. Está disponible con acabado lacado mate en las variantes de color blanco y negro. Realizado bajo demanda en todos los colores RAL. Foulard-ino. Pequeña y refinada, está formada por un doble apoyo de MDF lacado con base de metal y una doble columna portante de MDF curvada. Está disponible con acabado lacado mate en las variantes de color blanco y negro. Realizada bajo demanda en todos los colores RAL.

**Technical data**  
— Foulard - Foulard-ino p. 290







# Honey

[IT] – Una piccola cella esagonale, uno scrigno segreto circondato da un morbido abbraccio, questo è Honey. Eclettico per natura, si reinventa a seconda delle necessità in un comodo pouf, un utile tavolino e un pratico contenitore. Ogni elemento ha una propria autonomia formale - funzionale e può essere utilizzato singolarmente. Ma non solo. Honey è un progetto perfettamente modulare, con la possibilità di accostare più elementi a formare un vero alveare. È disponibile in una vasta gamma di colori abbinabili, anche differenziando i toni tra cuscino e struttura. I piani in MDF sono disponibili con finitura laccata opaca nelle varianti colore bianco o grigio.

Design Calvi & Brambilla  
Production year 2013

[EN] — A small hexagonal cell, a secret casket held in a warm embrace: this is Honey. Eclectic by nature, Honey adapts to the needs of the moment, becoming a comfortable pouf, a handy occasional table or a practical container. Each element is functionally independent and can be used separately. But that's not all. Honey features a seamless modular design, and the various elements can be attached and combined to form a veritable honeycomb. Available in a wide range of colours, it is perfect for mixing and matching, or choosing contrasting hues for the cushions and the structure. The MDF tops are available in a matt lacquered finish in white or grey.

[FR] — Une petite cellule hexagonale, un écrin secret pris dans une douce étreinte, voilà ce qu'est Honey. Éclectique par nature, cet objet se transforme suivant les besoins en pouf, table basse ou élément de rangement astucieux. Chaque élément a sa propre autonomie formelle et fonctionnelle et peut être utilisé individuellement. Mais ce n'est pas tout. Honey est un projet parfaitement modulaire, avec la possibilité de juxtaposer plusieurs modules de manière à former une véritable ruche. Il est disponible dans une gamme étendue de couleurs assortis, avec possibilité d'alterner les couleurs entre coussin et structure. Les plateaux en MDF sont disponibles en finition laquée mate en blanc ou gris.

[ES] — Una pequeña celda hexagonal, un cofre secreto rodeado por un suave abrazo, esto es Honey. De esencia ecléctica, según las necesidades se reinventa como un cómodo puf, una servicial mesa de centro y un práctico contenedor. Cada elemento dispone de una propia autonomía formal y funcional y puede utilizarse individualmente. Pero no sólo esto. Honey es un proyecto perfectamente modular, con la posibilidad de adosar varios módulos que componen una verdadera colmena. Disponible en una amplia gama de colores combinados, aún diferenciando los tonos entre cojín y estructura. Los tableros de MDF están disponibles con acabado lacado mate en las variantes de color blanco y gris.

Technical data  
→ Honey p. 290



Saba Italia — Low table

Honey

Tavolini  
Low tables  
Tables basses  
Mesas de centro



# Biscotto

[IT] – Pouf seduta rotondo trapuntato, Biscotto è un elemento informale dal carattere indipendente che si presta all'accostamento con altri elementi.

Technical data  
— Biscotto p. 290

Design Sergio Bicego  
Production year 2005

[EN] – Round quilted pouf, Biscotto is an informal piece with an independent personality, ideal for combination with other elements.

[FR] – Pouf avec assise ronde matelassée, Biscotto est un élément informel au caractère indépendant qui se prête à une juxtaposition à d'autres éléments.

[ES] – Puf de asiento redondo pespunteado, Biscotto es un elemento informal de carácter independiente que se armoniza con otros elementos.





# Shade

**[IT] – In giapponese Shade indica il paravento. Saba reinterpretata l'oggetto in chiave contemporanea destinandogli un posto nel living. Shade è un filtro, una quinta, un piccolo sistema che si compone costruendo gli spazi, decorando, separando, ritagliando angoli di privacy. Le due misure e le diverse finiture permettono di creare ambienti fortemente caratterizzanti, scegliendo tra diversi tessuti che si accostano armoniosamente agli imbottiti e agli accessori. La forma morbida priva di angoli è la cifra riconducibile al poetico segno progettuale del designer Marco Zito.**

Technical data  
→ Shade p. 291

Design Marco Zito  
Production year 2014

[EN] – Shade, as in the Japanese meaning of "divider". Saba has restyled this item in a contemporary rethink and found it a place in the living area. Shade is a filter, a divider, a compact system created by constructing spaces, decorating, separating, reserving private and intimate corners. The two sizes and the different finishes allow highly distinctive spaces to be created, with a choice of different fabrics perfectly coordinated with the upholstery and accessories. The soft shape without corners is the feature which links up to the lyrical design style of designer Marco Zito.

[FR] – En japonais Shade indique le paravent. Saba réinterprète l'objet sous un jour contemporain en lui donnant une place dans le séjour. Shade est un filtre, un panneau, un petit système qui se compose en construisant les espaces, en décorant, en séparant, en créant des coins intimes. Les deux dimensions et les différentes finitions permettent de créer des environnements distincts à travers la sélection des tissus qui se coordonnent harmonieusement avec les meubles rembourrés et les accessoires. La forme douce sans angles vifs renvoie immédiatement la poésie qui caractérise les créations du designer Marco Zito.

[ES] – En japonés, el término Shade indica el biombo. Saba reinterpretata este objeto en clave contemporánea y le asigna un lugar en la sala de estar. Shade es un filtro, un bastidor, un pequeño sistema que se compone construyendo los espacios, decorando, separando y delimitando rincones de privacidad. Las dos medidas y los distintos acabados permiten crear ambientes de gran personalidad, eligiendo entre distintos tejidos que se combinan armoniosamente con los acolchados y los complementos. La forma suave sin esquinas es la cifra inspiradora de la poética peculiaridad de diseño de Marco Zito.

Shade

Paraventi, divano New York Soft  
Dividers, New York Soft sofa  
Paravents, canapé New York Soft  
Biombos, sofà New York soft





## Primo Quarto

[IT] – **Libreria leggera e dalla vena poetica che ripropone la linea arcuata di una luna crescente. Funzionale e al tempo stesso dal forte impatto decorativo, Primo Quarto è costituita da ripiani e divisori interni inclinati che ne seguono l'andamento curvilineo per un effetto decisamente armonioso. Primo Quarto è disponibile nella versione a terra o pensile in legno laccato bianco opaco.**

Technical data  
→ Primo Quarto p. 291

Design Giuseppe Viganò  
Production year 2009

[EN] – This light, poetic bookcase is arched rather like a waxing moon. Functional and visually incisive, it consists of slanting internal shelves and dividers that create a curved line, creating an extremely harmonious effect. Primo Quarto is available either in the free-standing version or the wall-attached version in matt white lacquered wood.

[FR] – Bibliothèque légère d'inspiration poétique qui recompose la ligne arquée d'un croissant de lune. Fonctionnelle mais aussi d'un grand impact décoratif, Primo Quarto est constituée d'étagères et de séparateurs internes inclinés qui en suivent l'évolution curviligne pour un effet très harmonieux. Primo Quarto est disponible en version terre ou crayon en bois laqué blanc mate.

[ES] – Librería ligera y de espíritu poético que repropone la línea curva de una luna creciente. Funcional y de gran impacto decorativo, Primo Quarto está formada por estantes y divisorios internos inclinados que acompañan las líneas curvilíneas creando un efecto indudablemente armonioso. Primo Quarto está disponible en la versión de suelo o colgante, en madera lacada blanco mate.



Primo Quarto

Libreria pensile 125x120 cm  
Poltrona Sitar, tavolino Più  
Wall-attached bookcase 125x120 cm  
Armchair Sitar, Più low table  
Bibliothèque suspendue 125x120 cm  
Fauteuil Sitar, table basse Più  
librería colgante 125x220 cm  
sillón Sitar, mesa de centro Più



Technical data  
Sofas, Armchairs,  
Sofa bed, Low tables  
and Furnishings

C—04





Pixel

Design Sergio Bicego  
— P. 004



Esempi composizioni / 3 moduli seduta da 122 cm, 3 schienali da 82 cm e 2 schienali da 122 cm  
Examples of compositions / 3 x 122 cm seating units, 3 x 82 cm backrests and 2 x 122 cm backrests

Moduli seduta / Seating units / 122

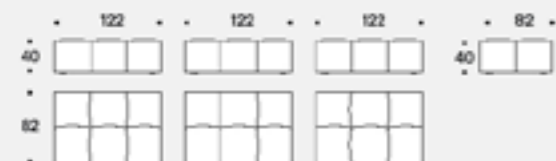

Schienali / Backrests / 82



Schienali / Backrests / 122

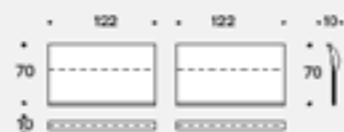

Esempi / Examples

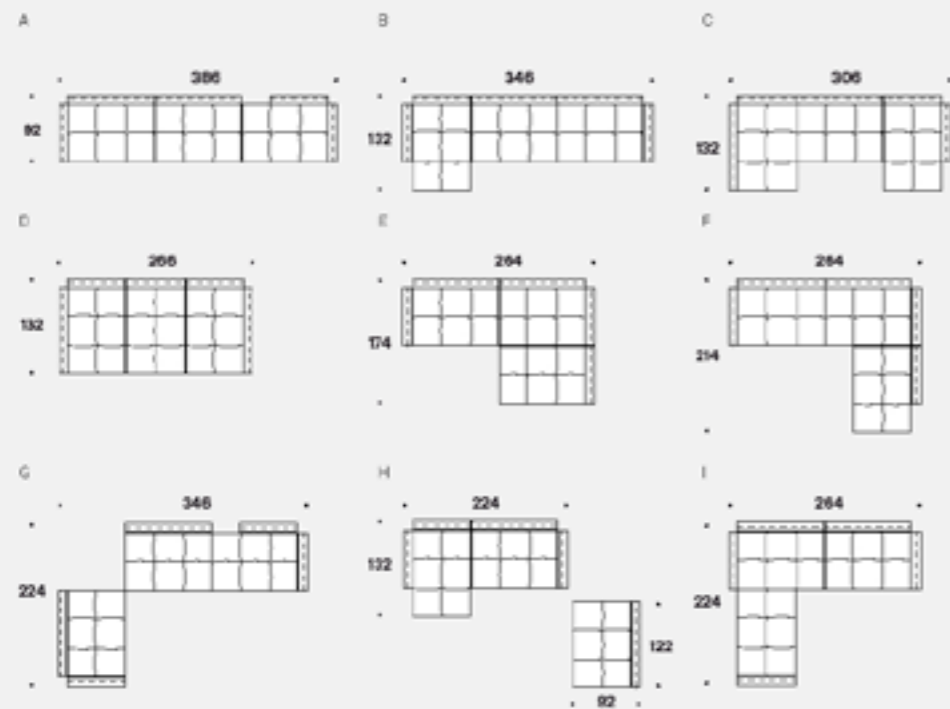

Schienali / Backrests



Moduli seduta / Seating units



Schienali bracciolo / Backrests armrest



Divani fissi / Fixed sofas



Pixel

Design Sergio Bicego  
— P. 004



Laterali fissi DX-SX / Fixed right-left side units



Angoli fissi / Fixed corner units



Centrali / Central units



Pensole fisse DX - SX  
Fixed right-left chaise longue / 174

Pensole fisse DX - SX  
Fixed right-left chaise longue / 214

Pensole fisse DX - SX  
Fixed right-left chaise longue / 254

Pensole fisse DX - SX  
Fixed right-left chaise longue / 132

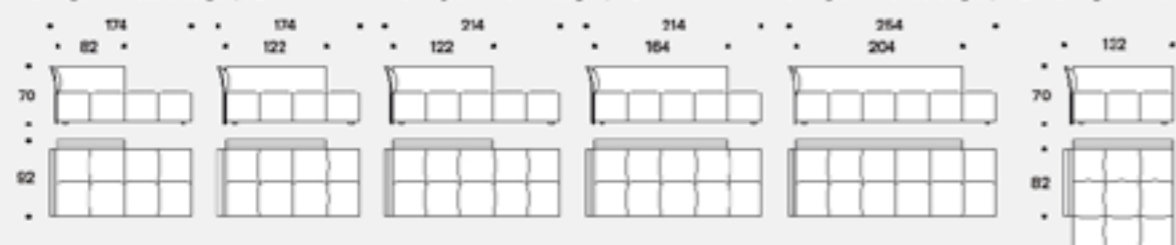

Pouf

Cuscini schiena / Back cushions

Cuscino a terra / Throw cushion

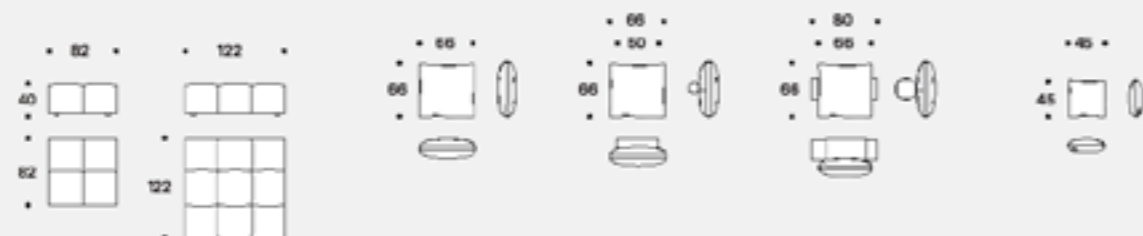

Up

Design Giuseppe Viganò  
— P. 022



Divani / Sofas



Laterali DX-SX / Right-left side units

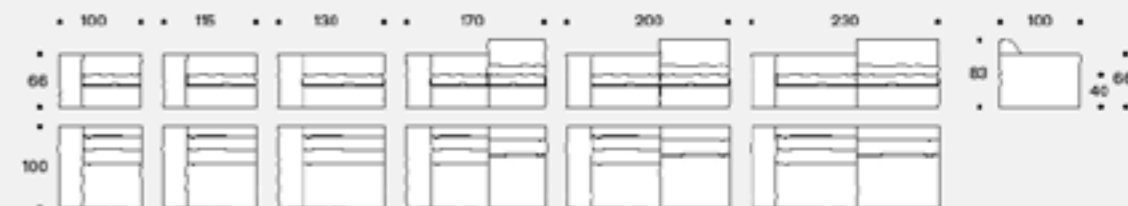

Centrali / Central units

Angolo / Corner unit

Pouf



Pensole DX-SX / Right-left chaise longue



### New York Suite

Design Sergio Bicego  
— P. 030



Divani / Sofas



Laterali CX-SX / Right-left side units



Fensole CX-SX / Right-left chaise longue

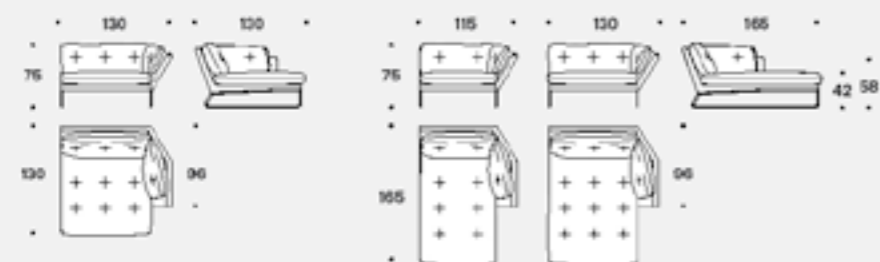

Poltrona lounge / Lounge armchair

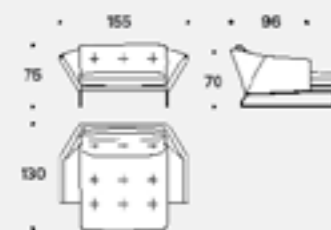

Poltrona lounge con braccioli  
Lounge armchair with armrests

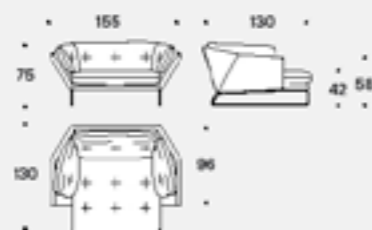

Pouf



### New York Soft

Design Sergio Bicego  
— Pixel p. 040



Divani / Sofas



Divani / Sofas



Laterali CX-SX / Right-left side units



Per isola CX-SX / Right-left chaise longue

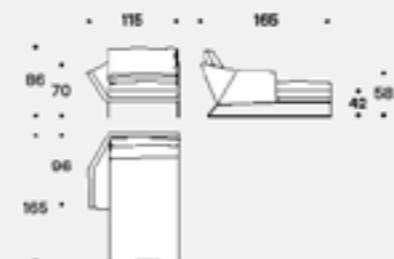

Pouf



**Livingston**

Design Giuseppe Viganò  
— P. 048



Divani / Sofas

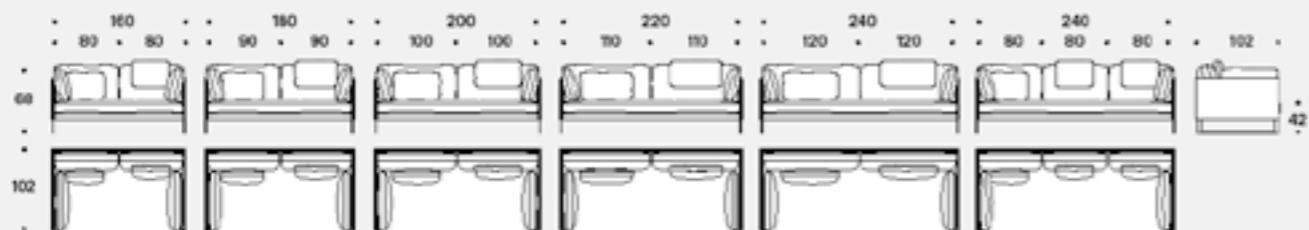

Laterali DX-SX / Right-left side units

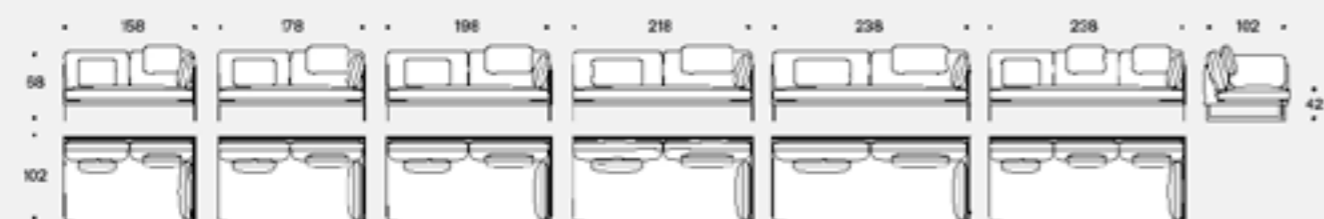

Divani angolari DX-SX / Right-left corner sofas

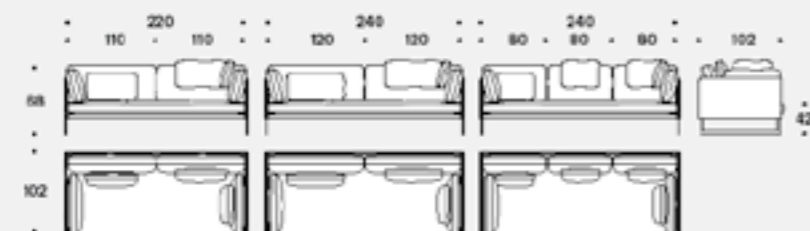

Laterali angolari DX-SX / Right-left corner side units

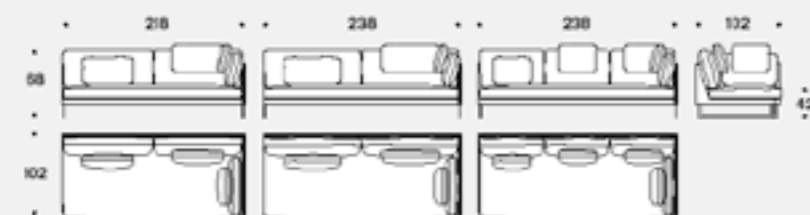

Terminali DX-SX / Right-left end unit

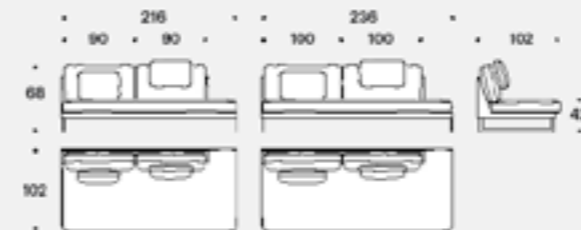

Terminali angolari DX-SX / Right-left corner end units

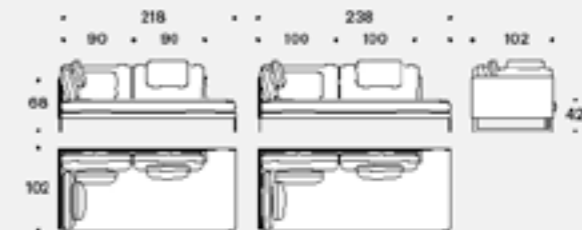

Meridienne DX-SX / Right-left Meridienne



Laterale DX-SX / Right-left side unit / 110



Per isola DX-SX / Right-left chaise longue / 160

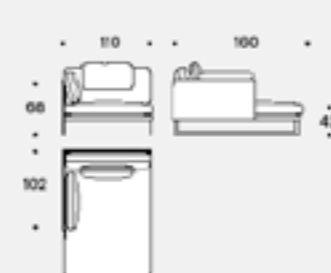

Penisola DX-SX / Right-left chaise longue / 180

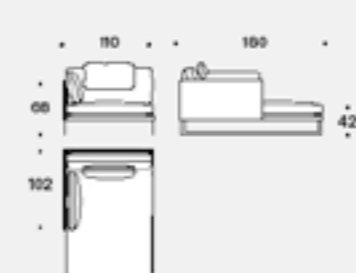

Potrona / Armchair



Pouf

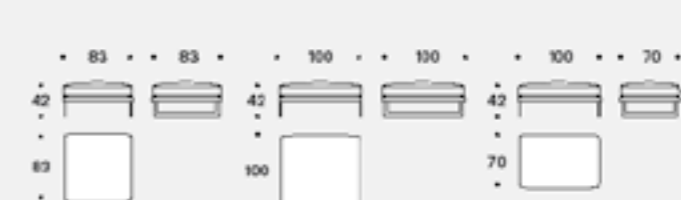

**Ananta Class**

Design Sergio Bicego  
— F. 058



Bracciolo / Armrest / 15



Schienali / Backrests / 15



Schienali angolari / Corner backrests / 15



Divani fissi / Fixed sofas / 15

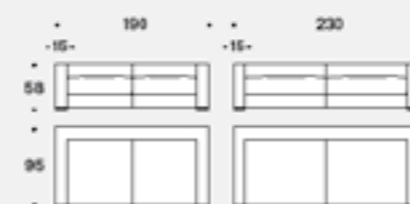

Divani fissi / Fixed sofas / 23



Bracciolo / Armrest / 23



Schienali / Backrests / 23



Schienali angolari / Corner backrests / 23



Laterali fissi DX-SX / Fixed right-left side units / 15

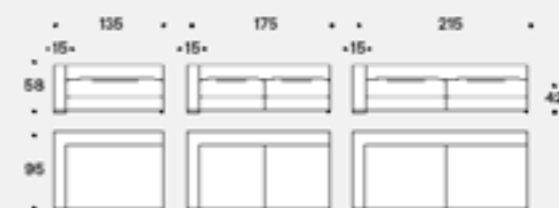

Laterali fissi DX-SX / Fixed right-left side units / 23



Moduli sedute / Seating units



Perisola fissa DX-SX 155 / Fixed right-left chaise longue 155 / 15

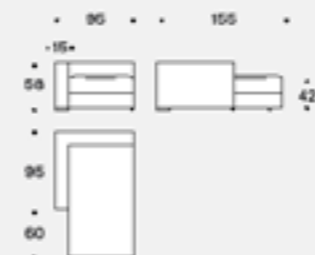

Perisola fissa DX-SX 163 / Fixed right-left chaise longue 163 / 23

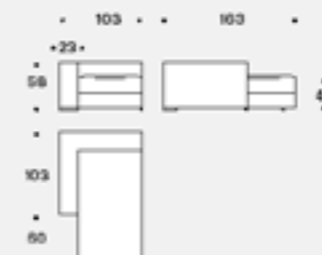

Cuscinii schienali / Back cushions



Tavolini / Low tables



Terminale fisso DX-SX 215 / Fixed right-left end unit 215 / 15

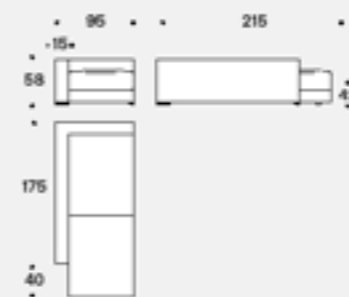

Terminale fisso DX-SX 215 / Fixed right-left end unit 215 / 23



### Essentiel

design Sergio Bicego  
— P. 074



Divani / Sofas

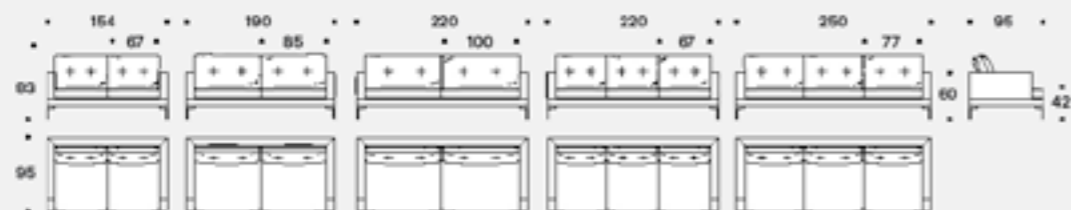

Laterali DX-SX / Right-left side units



Angolare / Corner



Pensole DX-SX / Right-left chaise longue



Terminale / End unit

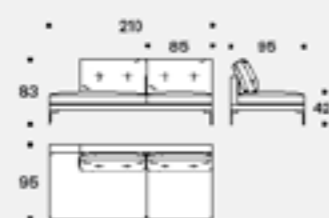

Terminale angolare DX-SX / Right-left corner end unit

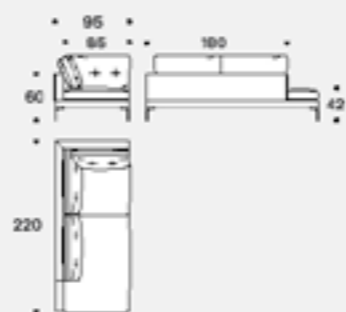

Cusconi schienali alti / High back cushions



Pouf



Poltrona / Armchair



### Eustier

Design Giuseppe Viganò  
— P. 086



Divani / Sofas



Cusconi / Cushions



Cuscino arredo / Throw cushion



Poltrona / Armchair



Limes

Design Sergio Bicego  
— P. 090



Moduli sedute / Seating units / 80



Fianco con schienale  
Side backrest / 80



Penisole  
Chaise longue / 80

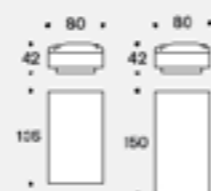

Moduli sedute / Seating units / 88



Fianco con schienale  
Side backrest / 88



Penisole  
Chaise longue / 88

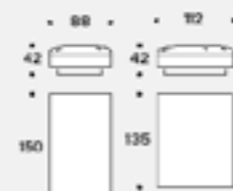

Moduli sedute / Seating units / 80 T20

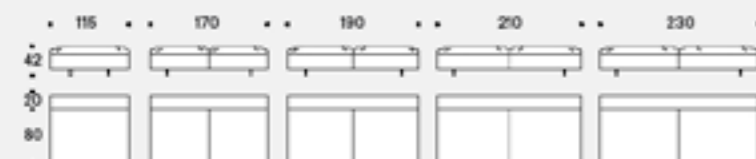

Fianco con schienale  
Side backrest / 80 T20



Penisole  
Chaise longue / 80 T20

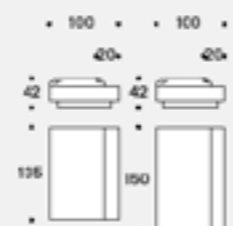

Moduli sedute / Seating units / 80 T40



Fianco con schienale  
Side backrest / 80 T40



Penisole  
Chaise longue / 112 T20



Moduli sedute  
Seating units / 80 T90

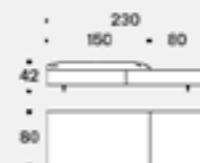

Fianco con schienale  
Side backrest / 80 T90



Base angolare / Corner unit

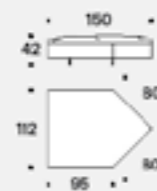

Schienali cromo - tessuto - intreccio fettucella - intreccio imbottito  
Chrome - fabric - tape braided - padded braided backrests



Braccioio cromo - tessuto - intreccio fettucella - intreccio imbottito  
Chrome - fabric - tape braided - padded braided armrests



Cusoni schiena /  
Backrest cushions



Cuscino bracciale  
Armrest cushion



Cusoni arredo  
Throw cushions



River

Design Sergio Bicego  
— P. 104



Centrali / Central units

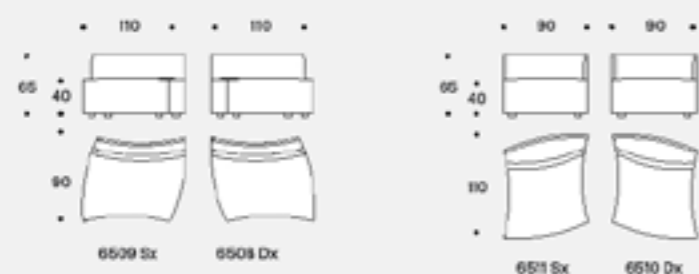

Angoli / Corner units

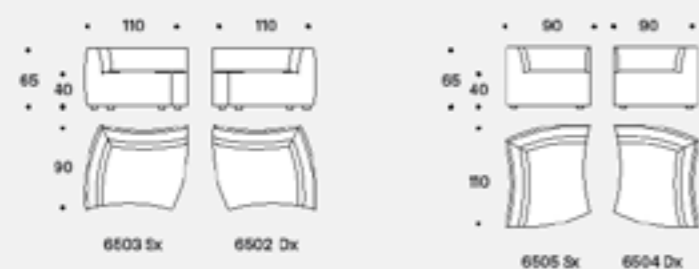

Piuf



Cusini / Cushions



Esempi composizioni / Examples of compositions

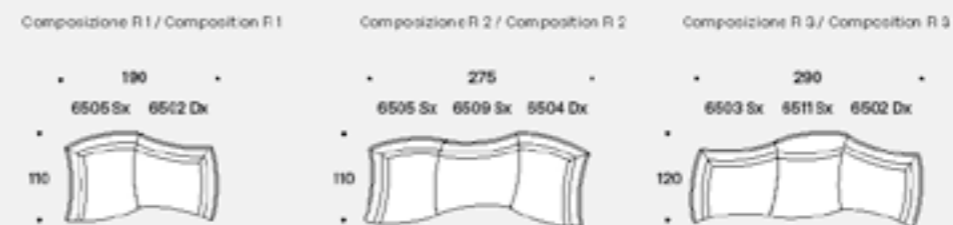

Composizione R4 / Composition R 4

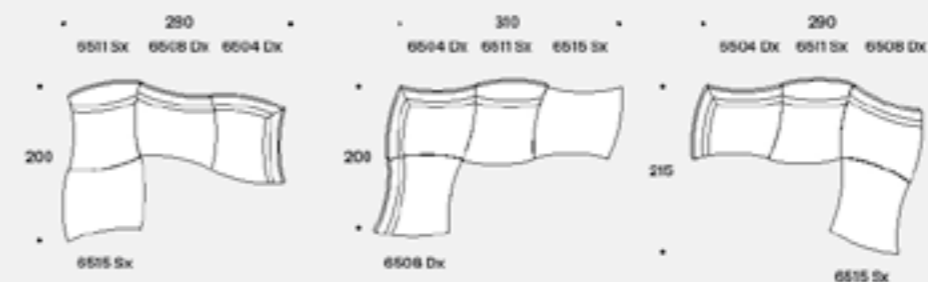

Composizione R4 / Composition R 4

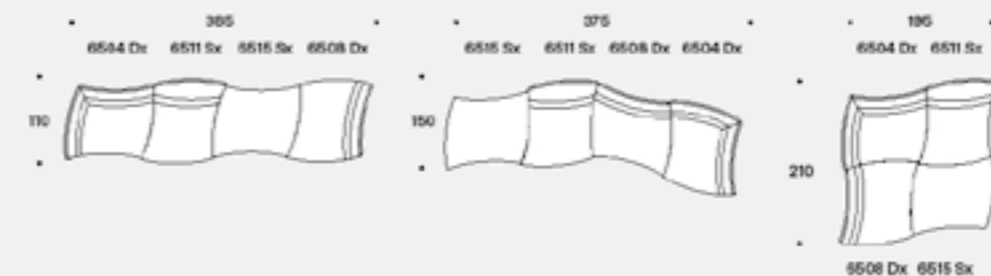

Composizione R5 / Composition R 5

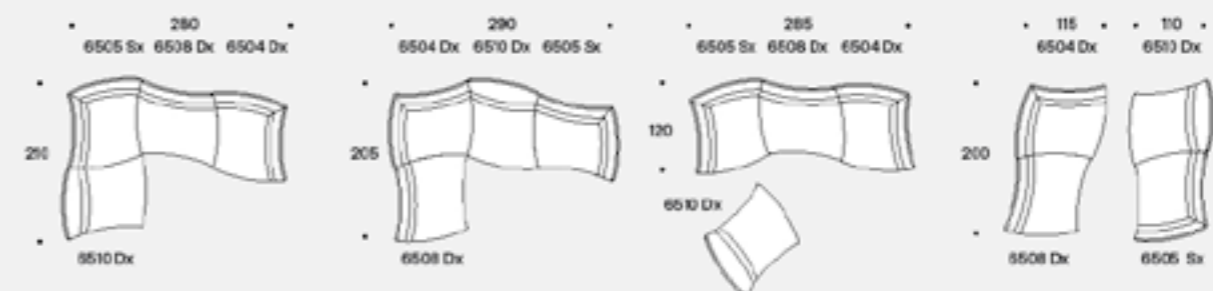



**Taos**

Design Sergio Bicego  
— P. 112



Divani / Sofas / 65  
Bracciolo / Armrest / 20

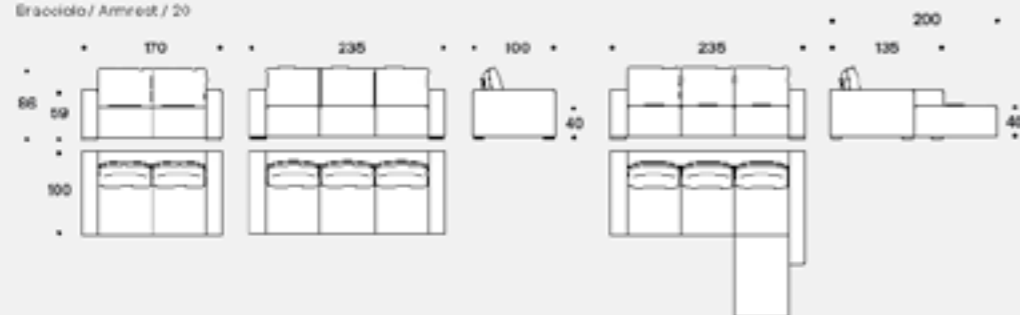

Divani / Sofas / 80  
Bracciolo / Armrest / 20

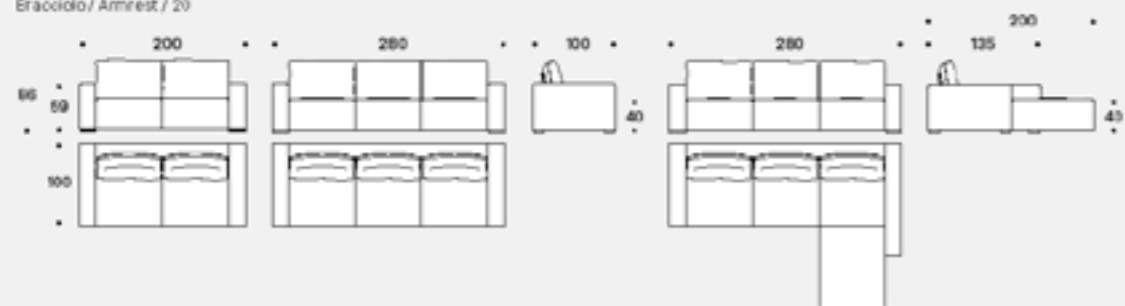

Divani / Sofas / 100  
Bracciolo / Armrest / 20

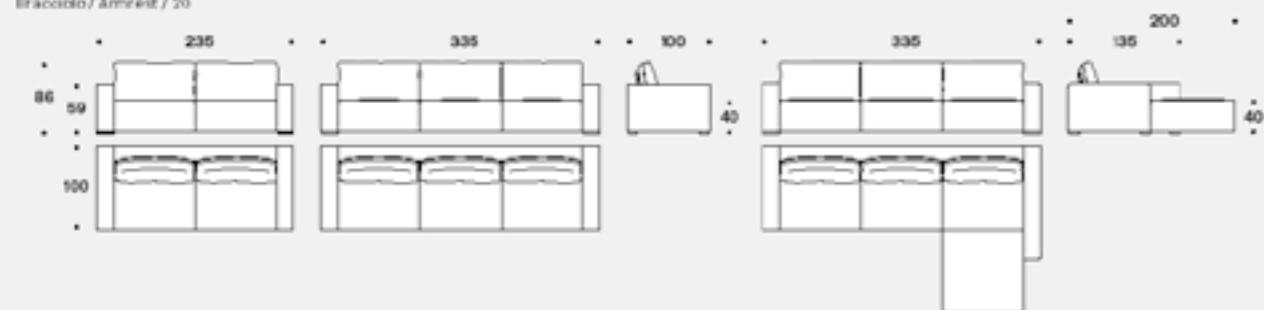

Divani / Sofas / Large 65  
Bracciolo / Armrest / 27

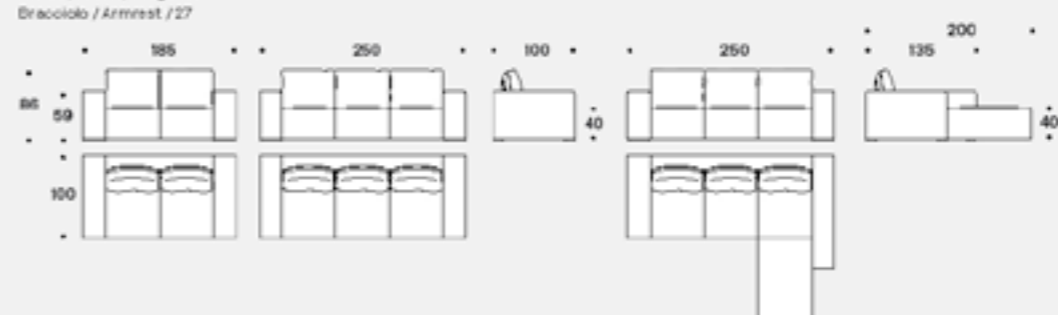

Divani / Sofas / Large 80  
Bracciolo / Armrest / 27

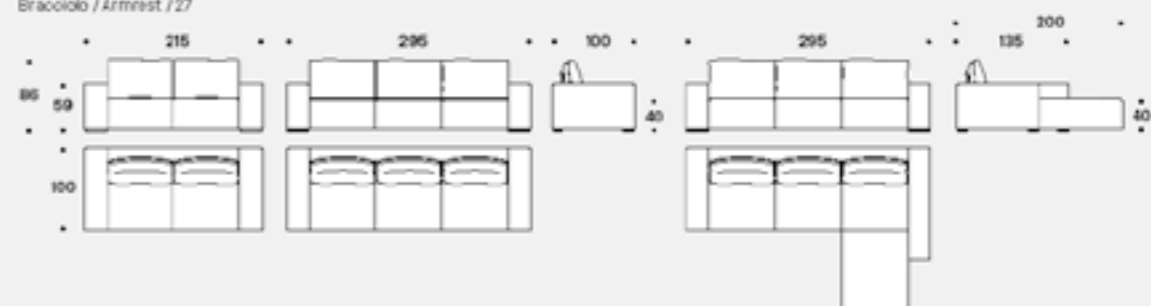

Divani / Sofas / Large 100  
Bracciolo / Armrest / 27

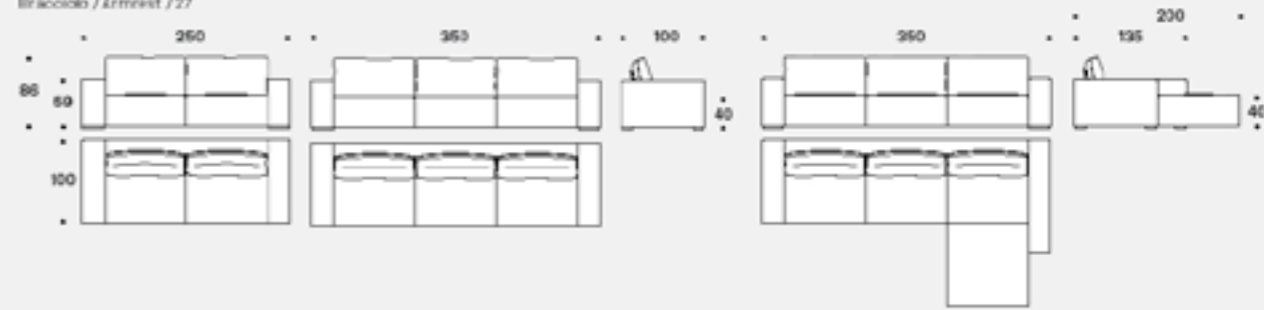

Poz.f

Cuscino / Cushion



Quinta Strada

Design Sergio Bicego  
— P. 118



Divani / Sofas

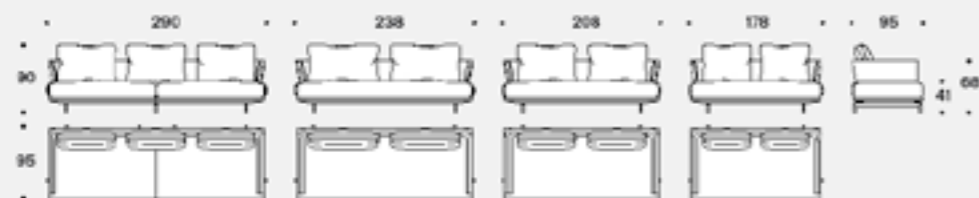

Laterali DX-SX / Right - left side units

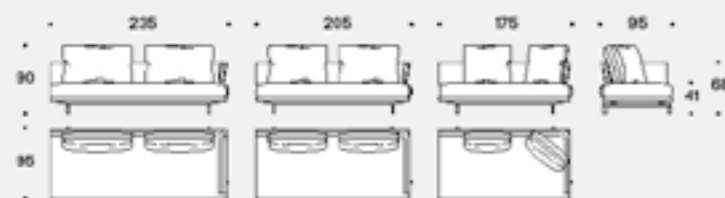

Terminali angolari DX-SX / Right-left corner units

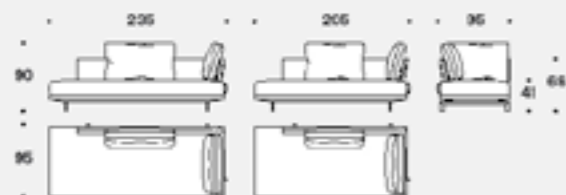

Perisola DX-SX / Right-left chaise longue

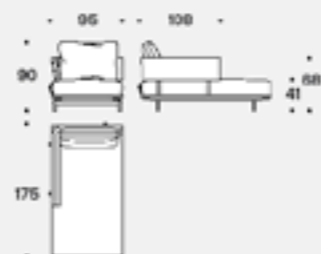

Pouf

Cuscini arredo / Throw cushions

Cuscino poggiatesta / Lower back cushion



Laterali DX-SX angolo 22,5° / Right - left 22,5° corner side units



Terminali DX-SX angolo 22,5° / Right - left 22,5° corner end units



Esempi composizioni angolo 22,5° con cuscini 62x52 cm / Examples of 22,5° corner compositions with cushions 62x52 cm

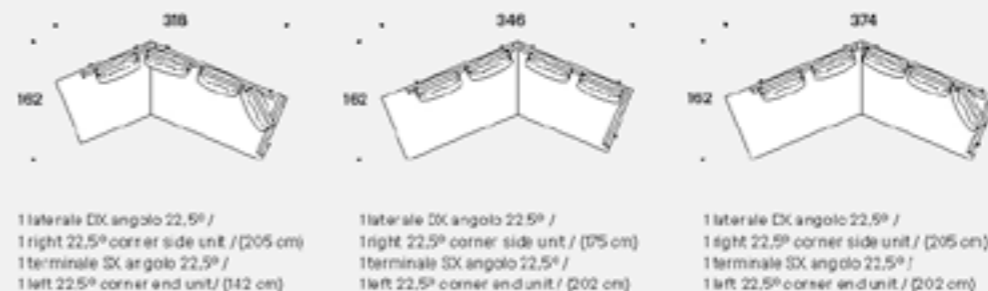
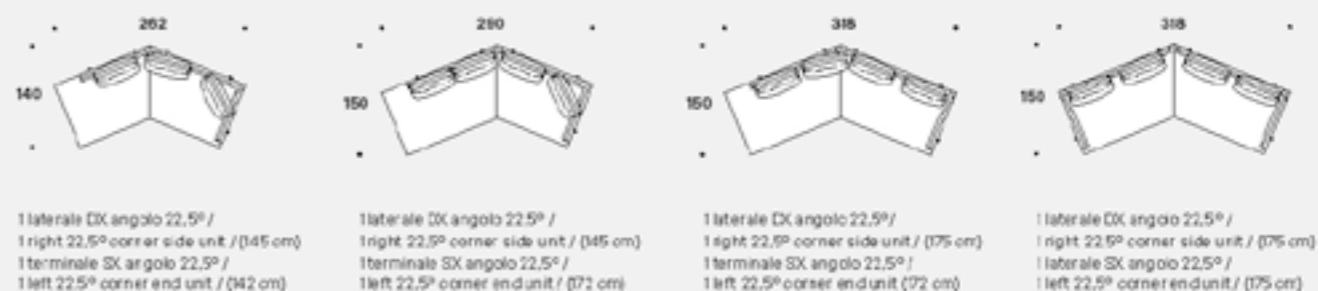

### Family

Design Marzia e Leonardo Dainelli  
— P. 126



Divani / Sofas

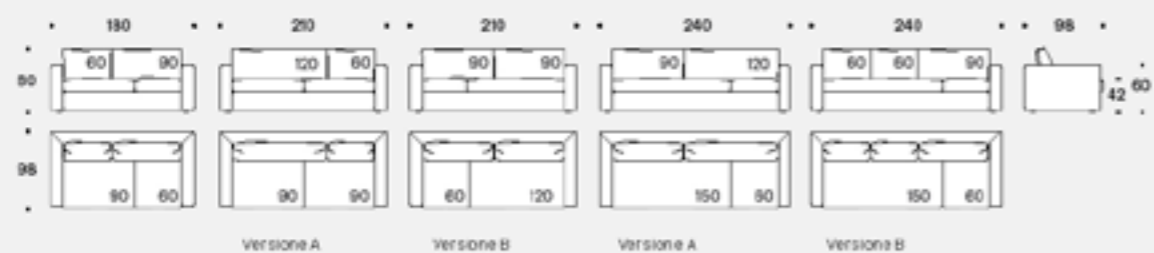

Divani / Sofas

Cusino schiena angolo  
Corner back cushion

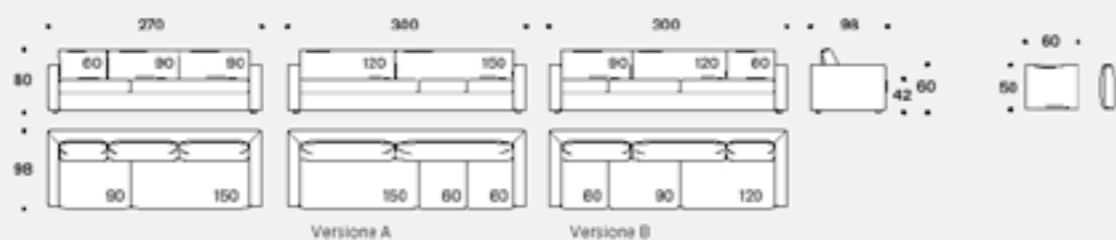

Laterali CX-SX / Right - left side units

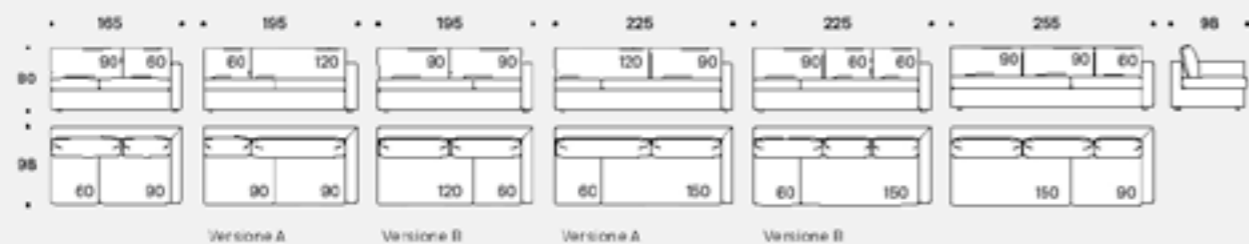

Laterali CX-SX / Right - left side units

Pouf

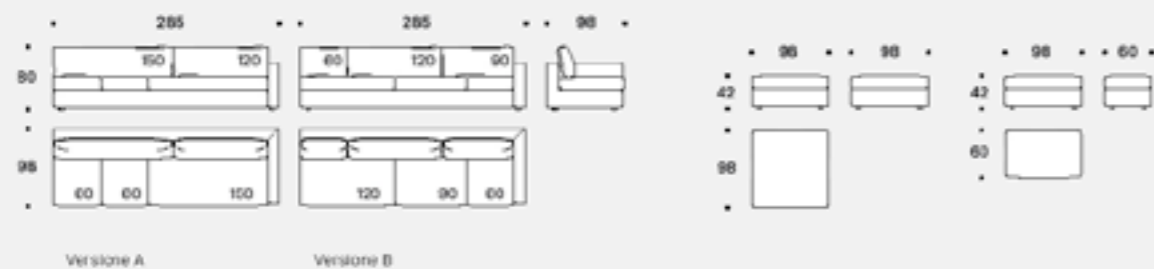

### Karma

Design Sergio Bicego  
— P. 136



Divani / Sofas

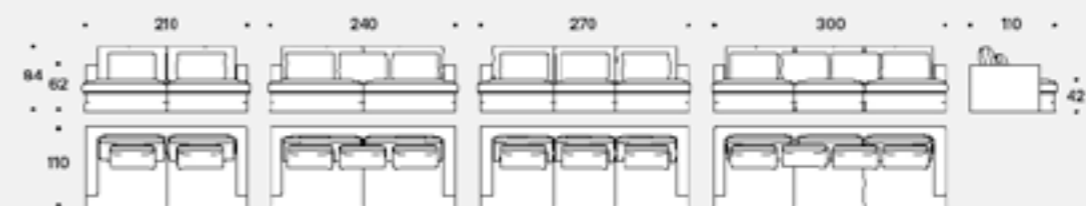

Laterali CX-SX / Right - left side units

Terminale angolare CX-SX / Right - left corner end unit



Per isola CX-SX / Right - left chaise longue

Angolare / Corner unit

Pouf



Poltrona / Armchair

Cusino arredo / Throw cushion



Opium

Design Sergio Bicego  
— P. 144



Divani / Sofa

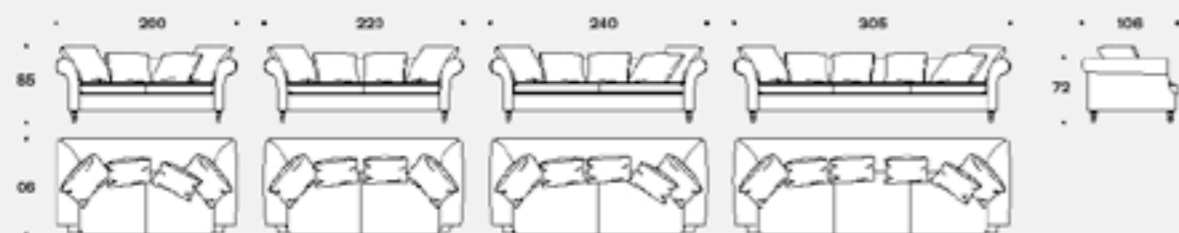

Laterali CX-SX / Right-left side units



Pensola SX-CX / Right-left chaise longue

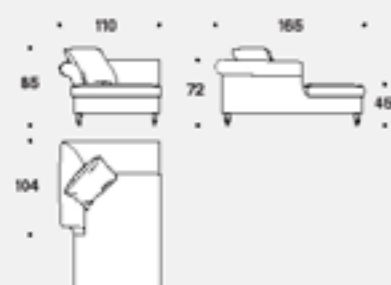

Poltrona / Armchair

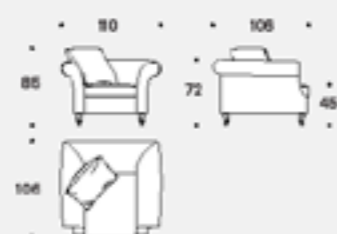

Pouf



Cuscini / Cushions



No logo basic

Design Sergio Bicego  
— P. 148



Divani / Sofa



Laterali CX-SX / Right-left side units



Pouf



Per isola CX-SX / Right-left chaise longue

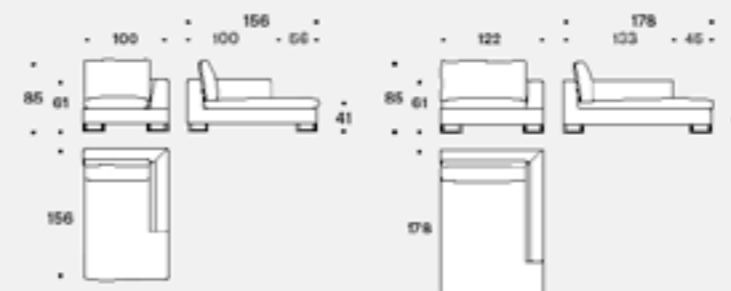

Terminale angolare CX-SX / Right-left corner end unit

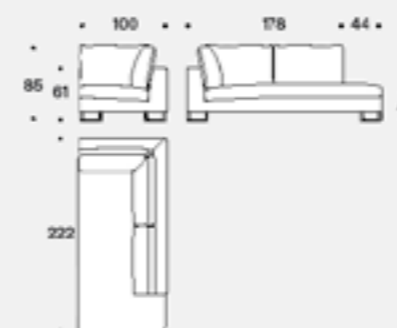

Angolare / Corner unit

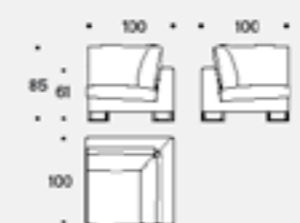

**Les femmes**

Design Giuseppe Viganò  
— P. 156



**Poltrone / Armchairs**

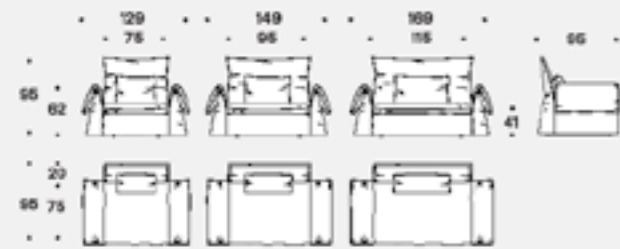

**Centrali / Central units**

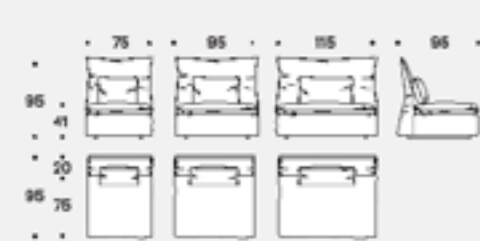

**Angolare / Corner**

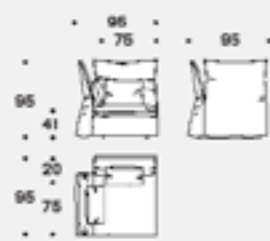

**Laterale CX-SX / Right-left side units**

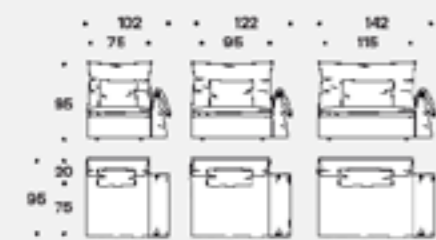

**Fianco con schienale rialzato e reclinato  
Side with raised and reclined backrest**

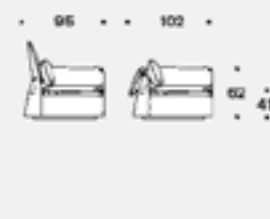

**Penisola CX-CX / Right-left chaise longue**

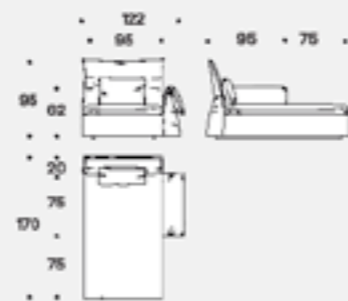

**Cusoni / Cushions**



**Pouf**

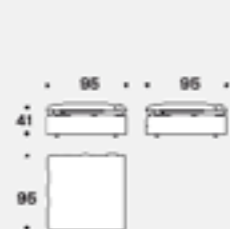

**Valentino**

Design Marzia e Leonardo Dainelli  
— P. 164



**Poltrone / Armchair**



**Pouf**



**Divani / Sofas**



### New York Armchair

Design Sergio Bicego  
— P. 170



Poltrona / Armchair

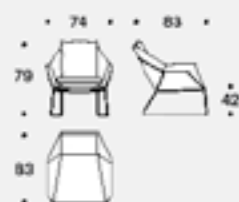

New York Armchair  
New York Bergère

Finitura struttura / Frame finish

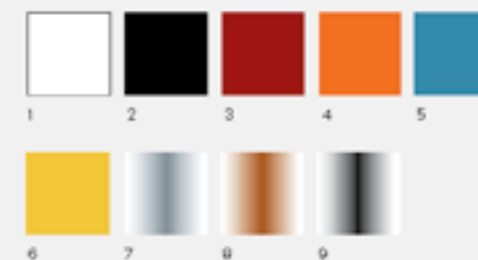

- 1 Bianco / White / Blanc / Blanco
- 2 Nero / Black / Noir / Negro
- 3 Rosso / Red / Rouge / Rojo
- 4 Arancio / Orange / Orange / Naranja
- 5 Azzurro / Blue / Bleu / Azul
- 6 Giallo / Yellow / Jaune / Amarillo
- 7 Cromo / Chrome / Chrome / Cromo
- 8 Rame / Copper / Cuivre / Cobre
- 9 Black nickel / Black nickel / Nickel noir / Niquel negro

### New York Bergère

Design Sergio Bicego  
— P. 178



Bergère / Bergère

Pouf

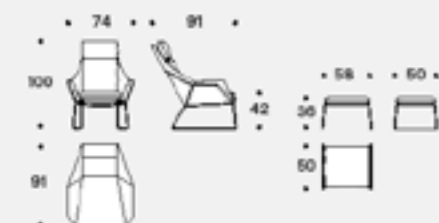

New York Chair

Finitura struttura / Frame finish



- 1 Bianco / White / Blanc / Blanco
- 2 Nero / Black / Noir / Negro
- 3 Cromo / Chrome / Chrome / Cromo
- 4 Black nickel / Black nickel / Nickel noir / Niquel negro

### New York Chair

Design Sergio Bicego  
— P. 180



Sedia con e senza braccioli / Chair with or without armrests

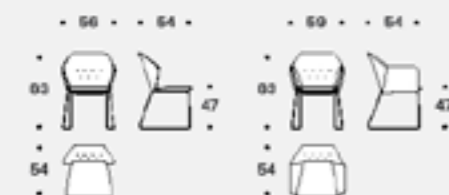

### New York Outdoor

Design Sergio Bicego  
— P. 184



Poltrona Outdoor / Outdoor Armchair

Finitura struttura / Frame finish

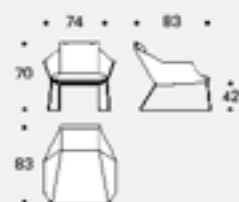

1  
1 Bianco / White / Blanc / Blanc

### Amélie

Design Sergio Bicego  
— P. 192



Poltrona / Armchair



### Valentine

Design Marzia e Leonardo Dainelli  
— P. 188



Poltrona / Armchair

Pouf



### Chance

Design Sergio Bicego  
— P. 196



Poltrona / Armchair



### Bustier

Design Giuseppe Viganò  
— P. 190



Poltrona / Armchair

Cuscino / Cushion

Cuscino arredo / Throw cushion

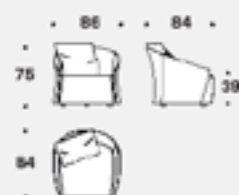

### No logo light

Design Sergio Bicego  
— P. 198



Poltrona / Armchair

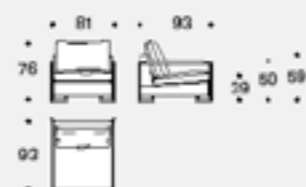

### Livingston

Design Giuseppe Viganò  
— P. 200



Poltroa / Armchair



### laCarmen

Design Giuseppe Viganò  
— P. 206



Poltroa / Armchair



Cerniere bianche o nere  
Black or white zips  
Zips noirs ou blancs  
Cremalleras blancas o negras

### Essentiel

Design Giuseppe Viganò  
— P. 202



Poltroa / Armchair



### Prêt-à-porter

Design Sergio Bicego  
— P. 208



Poltroa / Armchair

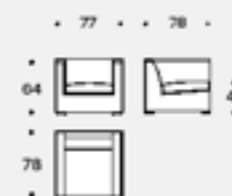

### Manta

Design Giuseppe Viganò  
— P. 204



Poltroa / Armchair

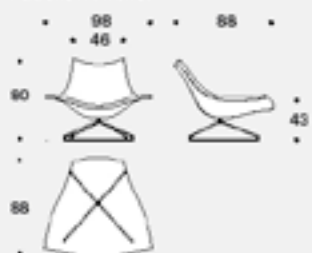

Finitura struttura / Frame finish



1 Bianco / White / Blanc / Blanco  
2 Cromo / Chrome / Chroma / Cromo

### Sitar

Design Enzo Berté  
— P. 210



Poltroa / Armchair



Finitura struttura / Frame finish

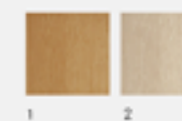

1 Miele / Honey / Miel / Mel  
2 Sbiancato naturale / Natural bleached  
Bianchi naturali / Natural Blanqueado



## Bed & Breakfast

Design Giuseppe Viganò  
— P. 212



Divano-letto / Sofa-bed

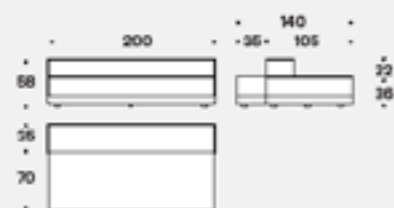

Chaise longue-letto / Chaise longue-bed

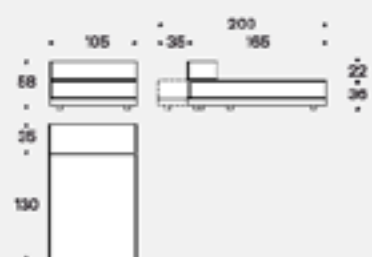

Cuscino / Cushion



## A song for you

Design Paolo Grasselli  
— P. 218



Tavolini / Low tables

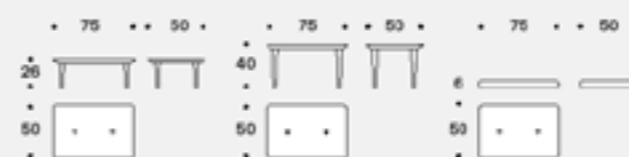

Finitura opaca piani / Table top matt finish



1 Bianco / White / Blanco / Bianco  
2 Zebirano

## Haiku

Design Marco Zito  
— P. 222



Tavolini / Coffee tables

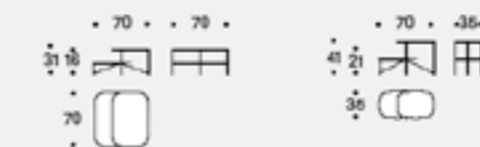

Finitura opaca struttura / Frame matt finish



1 Nero / Black / Noir / Negro

Finitura piani / Table top finish



1 Rosa antico / Old rose / Vieux rose / Rosa antiguo  
2 Cipria / Mud cream / Rose char / Maquillage  
3 Verde lichene / Moss reen / Vert lichen / Verde licuen  
4 Verde militare / Military green / Vert khaki / Verdemilitar  
5 Tortora / Taupe / Tourterelle / Cric ceniciento  
6 Azzurro Irlanda / Irish blue / Bleu irlandais / Azul Irlanda  
7 Grigio / Grey / Gris / Gris

### Leyva

Design Giuseppe Viganò  
— P. 226



Tavolini / Low tables

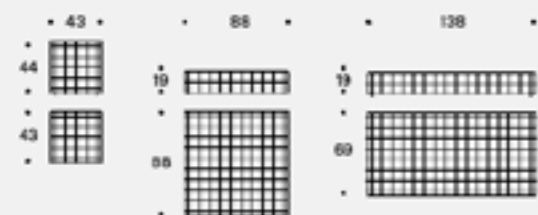

Finitura lucida struttura / Frame glossy finish



- 1 Bianco / White / Bianco / Blanco
- 2 Nero / Black / Noir / Negro

### Più Table

Design Giuseppe Viganò  
— P. 228



Tavolini / Coffee tables

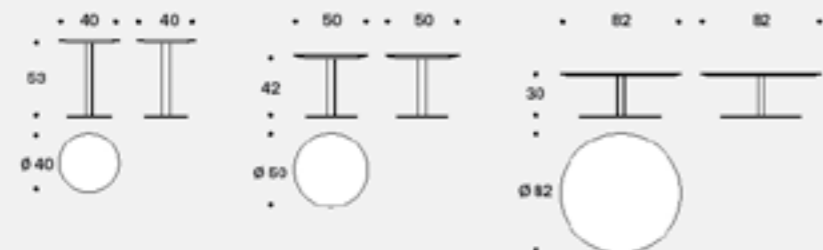

Finitura opaca piani e struttura / Matt table top and structure finish



- 1 Bianco / White / Bianco / Blanco
- 2 Rosso / Red / Rouge / Rojo
- 3 Nero / Black / Noir / Negro
- 4 Turchese / Turquoise / Turquoise / Turquesa
- 5 Bronzo / Bronze / Bronze / Bronce
- 6 Argento / Silver / Argent / Plata

### Ziggy XL / Ziggy

Design Emilio Nanni  
— P. 230



Tavolino / Low table



Finitura struttura / Frame finish



- 1 Grigio / Grey / Gris / Gris /
- 2 Rosso / Red / Rouge / Rojo
- 3 Azzurro / Blue / Bleu / Azul
- 4 Verde oliva / Olive green / Vert olive / Verde oliva

Finitura cima / Topes finish - pouf

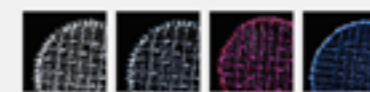

- 1 Grigio / Grey / Gris / Gris
- 2 Verde / Green / Vert / Verde
- 3 Rosso / Red / Rouge / Rojo
- 4 Azzurro / Blue / Bleu / Azul

Finitura top / Top finish



- 1 Marmo Thalabeige

Tavolini botte e clessidra / Low table - barrel and hourglass



Finitura piani e struttura / Top and frame finish - low table



- 1 Grigio / Grey / Gris / Gris
- 2 Verde / Green / Vert / Verde
- 3 Rosso / Red / Rouge / Rojo
- 4 Azzurro chiaro / Light blue / Bleu clair / Azul claro

Pouf botte e clessidra / Pouf - barrel and hourglass

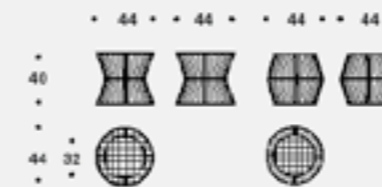

Finitura cima / Topes finish - pouf



- 1 Grigio / Grey / Gris / Gris
- 2 Verde / Green / Vert / Verde
- 3 Rosso / Red / Rouge / Rojo
- 4 Azzurro / Blue / Bleu / Azul

Finitura struttura / Frame finish



- 1 Grigio ardesia / Slate grey / Gris ardese / Gris pizarra

### Foulard / Foulard-ino

Design Giuseppe Viganò  
— P. 236



Tavolini / Low tables



Finitura opaca piani e struttura / Top and frame matt finish



1 Bianco / White / Bianco / Bianco  
2 Nero / Black / Noir / Negro

### Shade

Design Marco Zito  
— P. 244



Paraventi / Dividers

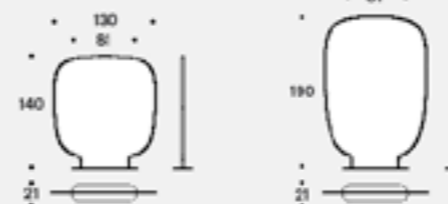

Finitura opaca struttura / Frame matt finish



1 Nero / Black / Noir / Negro

### Honey

Design Fabio Calvi e Paolo Brambilla  
— P. 238



Pouf contenitore / Pouf container

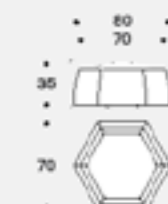

Tavolino contenitore / Low table container



Finitura opaca piani / Table top matt finish



1 Bianco / White / Blanc / Bianco  
2 Grigio / Grey / Gris / Gris

### Primo Quarto

Design Giuseppe Viganò  
— P. 248



Libreria pensile / Wall bookcase

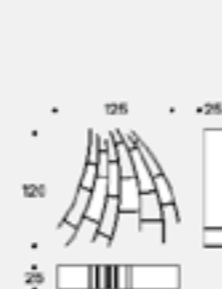

Libreria alta / High Bookcase

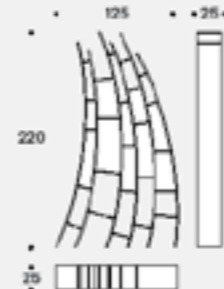

Finitura opaca struttura / Frame matt finish



1 Bianco / White / Blanc / Bianco

### Biscotto

Design Sergio Bicego  
— P. 242



Pouf



**Saba Italia**

35018 S. Martino di Lupari  
Padova / Italy  
via dell'Industria, 17  
T +39 049 946 2227  
F +39 049 946 2219  
infosaba@sabaitalia.it  
www.sabaitalia.it

credits

project coordinator  
Amelia Pegorin

art direction  
Artemio Croatto / Designwork  
graphic layout  
Annarosa Moro / Designwork

photo  
Paolo Contratti / ContrattiCompany  
stylist  
Vanda Gemino

copy  
Alessandra Santi  
translation texts  
Studio Intra  
PSG Srl

paper  
Curious Matter Andina Grey 270 gr  
Arctic volume white 130 gr  
Arcoprint E.W. 90 gr

fonts in New Rail Alphabet:  
New Rail Alphabet Light  
New Rail Alphabet Regular  
New Rail Alphabet Bold

color separation  
Lucegroup.it  
made and printed  
Italy, March 2016  
by Grafiche Antiga

thanks to  
GioveLab - [www.giovelab.it](http://www.giovelab.it)  
Brigitte Brand.it

