

03 /
novamobili collection /

letti e collezioni
per progettare l'ambiente notte /
beds and collections
to design the night environment /

ABOUT NIGHT

ABOUT NIGHT

Linee contemporanee e particolari ricercati definiscono lo spazio notte in un equilibrato dialogo tra forme e materiali.

Dettagli che impreziosiscono le nuove collezioni in cui legni, ecolegni ed una sofisticata gamma di tessuti disegnano il progetto Novamobili Night.

Contemporary lines and stylish details define the bedroom space in a well balanced dialogue between form and material.

Details add the wow factor to new collections, with different wood and eco-wood finishes and a sophisticated range of fabrics coming together to shape the Novamobili Night project.

BEDS & COLLECTIONS

TECHNICAL

10	room 01 Giotto/ Siri	62	room 08 Norman/ Mado	114	room 15 Overlap/ Dodo/ Liberty	175 179	Finiture/ <i>Finishes</i> Disegni Tecnici/ <i>Technical drawings</i>
16	room 02 Giotto/ Siri Soft/ Allison	70	room 09 Doty/ Brick	124	room 16 Globe/ Dedalo		
26	room 03 Platone/ Margot	76	room 10 Doty/ Circe/ Middle	130	room 17 Globe/ Bend		
32	room 04 Platone/ Kalé/ Picture	84	room 11 Doty/ One	138	room 18 Easy/ Sheet		
42	room 05 Quarantacinque/ Park	92	room 12 Pitagora/ Dream	144	room 19 Easy/ Time		
48	room 06 Quarantacinque/ Grace	98	room 13 Pitagora/ Softy/ Perry	150	room 20 Easy/ Nido/ Alfa		
56	room 07 Norman/ Noah	108	room 14 Overlap/ Ariel	160	room 21 Easy/ Twiggy		
				166	room 22 Easy/ Line		

NIGHT
BEDS & COLLECTIONS



room 01

siri bed
giotto collection

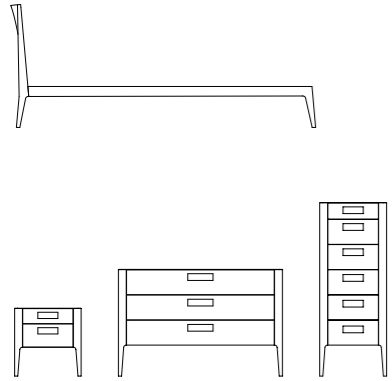

Linee semplici ed eleganti caratterizzano questo ambiente raffinato dove il letto Siri dialoga con la collezione Giotto.

Simplicity and elegance are the keywords in this room, where the Siri bed sits happily alongside the Giotto collection.

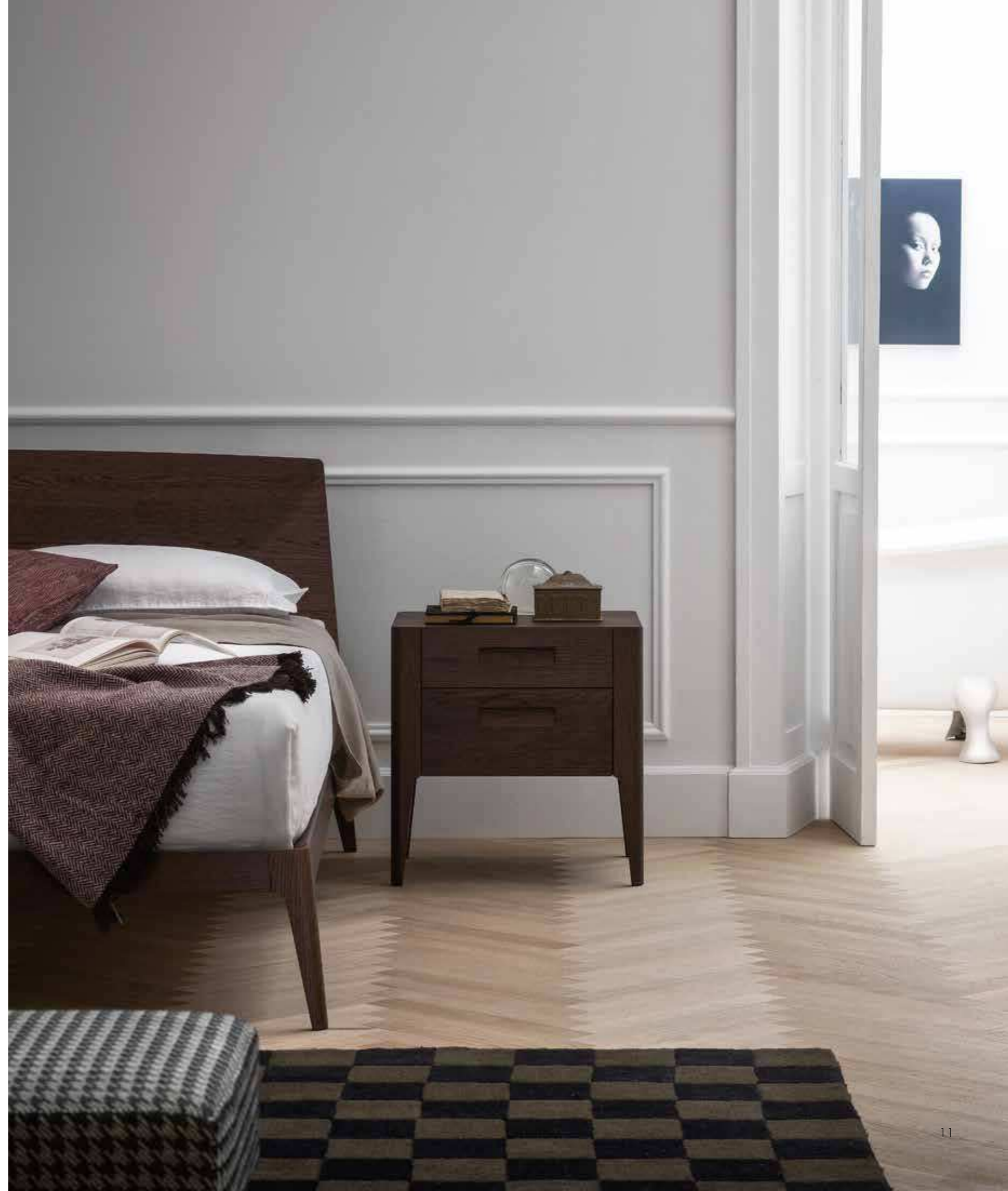





A fianco: comodino Giotto composto da due cassetti apribili, con maniglia integrata.
Sopra letto Siri, dal design senza tempo disponibile in rovere terra e rovere miele.

Nella pagina successiva, dettaglio del comò Giotto in finitura rovere terra.

Left: Giotto bedside table comprising two drawers that open, with built-in handle.
Top: Siri bed with its timeless design, comes in rovere terra and rovere miele.

Opposite: detail of Giotto chest of drawers in rovere terra finish.



room 02

siri soft bed
giotto collection
allison wardrobe

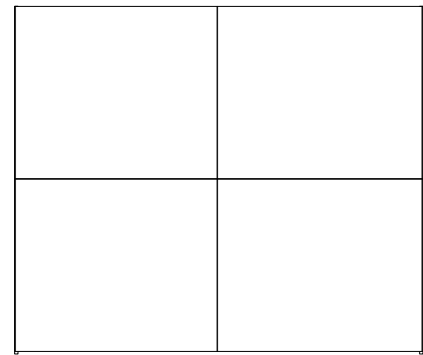
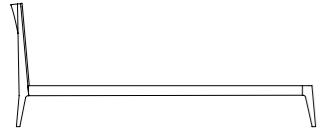

Forme geometriche e tessuti pregiati si mescolano in un sottile equilibrio tra tradizione ed innovazione.

Geometric shapes and rich fabrics are mixed together, striking a fine balance between tradition and innovation.

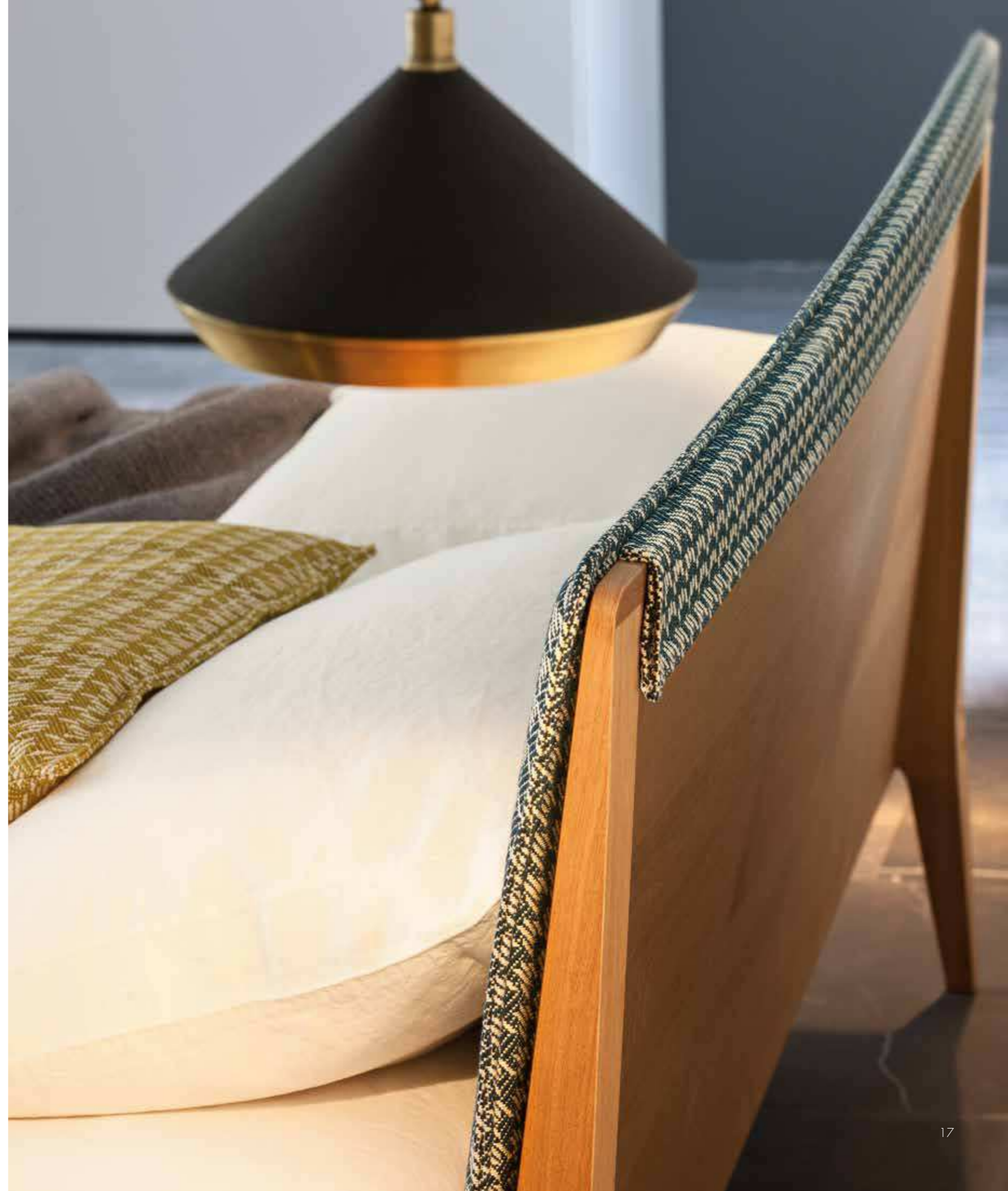





Collezione Giotto in versione rovere miele, nella pagina precedente i due settimanali e in alto a destra il comodino. A fianco, dettaglio dell'innesto del piede con il giroletto.



Giotto collection in rovere miele version. Opposite: the two tallboys. This page, top: the bedside table. This page, right: detail of foot meeting the bed surround.





Nella pagina a fianco, armadio scorrevole con anta Allison in finitura laccato grigio opaco e gola laccata in tinta.
In alto a sinistra, dettaglio del profilo maniglia.

*Opposite: wardrobe with sliding Allison door in grey matt lacquered finish and profile lacquered to match.
This page, top: detail of edge handle.*





room 03

margot bed
platone collection

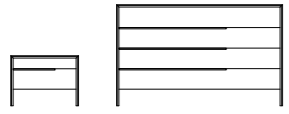
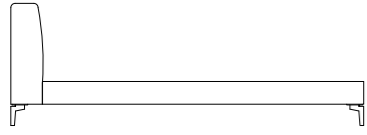

Estetica all'insegna della leggerezza in cui superfici morbide si contrappongono a volumi netti e materici.

This look is all about lightness, featuring soft surfaces contrasting with more solid, sharply defined volumes.







Nella pagina precedente dettaglio del retroletto in tessuto lucky 15.
Nell'immagine in alto a destra comodino Platone, in finitura rovere terra.
A fianco, dettaglio della gamba in finitura metallo black nichel lucido.



Opposite: detail of back of bed in lucky 15 fabric.
This page, top: Platone bedside table in rovere terra finish.
This page, right: detail of leg in polished black nickel metal finish.

room 04

kalé bed
platone collection
picture wardrobe

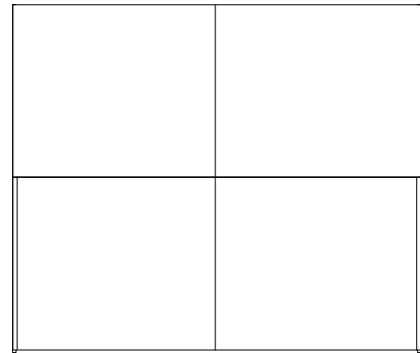

Rigore e morbidezza si fondono in questa stanza caratterizzata da letto Kalé e collezione Platone.

A juxtaposition of sharp lines and softness sets the tone in this room featuring the Kalé bed and Platone collection.







Nella pagina a fianco comò Platone in finitura rovere miele.
Sopra, dettaglio della maniglia in battuta al fianco.
A sinistra, comodino Platone e particolare letto Kalé, giroletto in finitura rovere miele e testiera in tessuto lucky 25.

*Opposite: Platone chest of drawers in rovere miele finish.
Above: detail of handle flush with side panel.
Left: Platone bedside table and detail of Kalé bed, surround in rovere miele finish and headboard in lucky 25 fabric.*



Nella pagina a fianco, armadio scorrevole con anta Picture laccato opaco fango, con maniglia gola in finitura nero grafite.

In questa pagina, dettaglio della giunzione tra i longoni con tagli a 45 gradi.

Sotto, letto Kalé con testiera in tessuto lucky 25 nella versione con giroletto Rho in finitura rovere miele.

Opposite: wardrobe with Picture sliding door in fango matt lacquered finish, with profile handle in nero grafite finish.

This page, left: detail of mitre joint where the side rail and end rail meet. Below: Kalé bed with headboard in lucky 25 fabric pictured in version with Rho bed surround in rovere miele finish.





room 05

park bed
quarantacinque collection

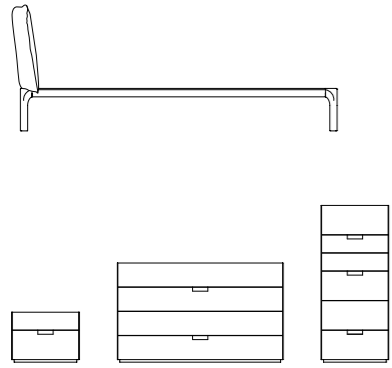

Ambiente sofisticato e ricercato, arricchito dai dettagli del letto Park e dalla collezione Quarantacinque.

Stylish, sophisticated interior, enriched with details courtesy of the Park bed and Quarantacinque collection.







In questa pagina: settimanali Quarantacinque in rovere terra con piano in vetro laccato bianco e particolare della testiera letto Park in tessuto tilt 10.
Nella pagina a fianco letto Park, giunzione tra giroletto e gamba in rovere terra.

*This page: Quarantacinque tallboys in rovere terra finish with white lacquered glass top and detail of headboard upholstered in tilt 10 fabric.
Opposite: Park bed, bed surround in rovere terra finish.*



room 06

grace bed
quarantacinque collection

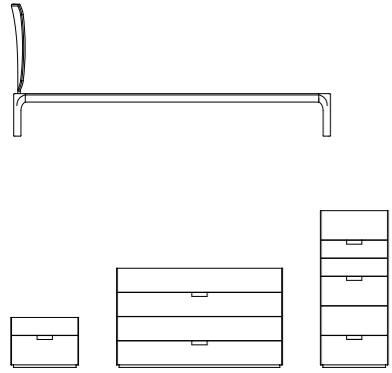

Grace, letto dalle linee curve, dialoga con il rigore geometrico della collezione Quarantacinque, creando un ambiente ricercato ed accogliente.

The Grace bed, with its curved lines, sits happily alongside the no-fuss geometric design of the Quarantacinque collection, creating a welcoming, stylish interior.







Nella pagina a fianco, comò Quarantacinque in finitura rovere miele.
Sopra, letto Grace e comodino Quarantacinque in finitura rovere miele.
A fianco particolare dell'attacco della gamba del letto Grace.

*Opposite: Quarantacinque chest of drawers in rovere miele finish.
This page, top: Grace bed and Quarantacinque bedside table in rovere miele finish.
This page, left: detail of leg joint on Grace bed.*

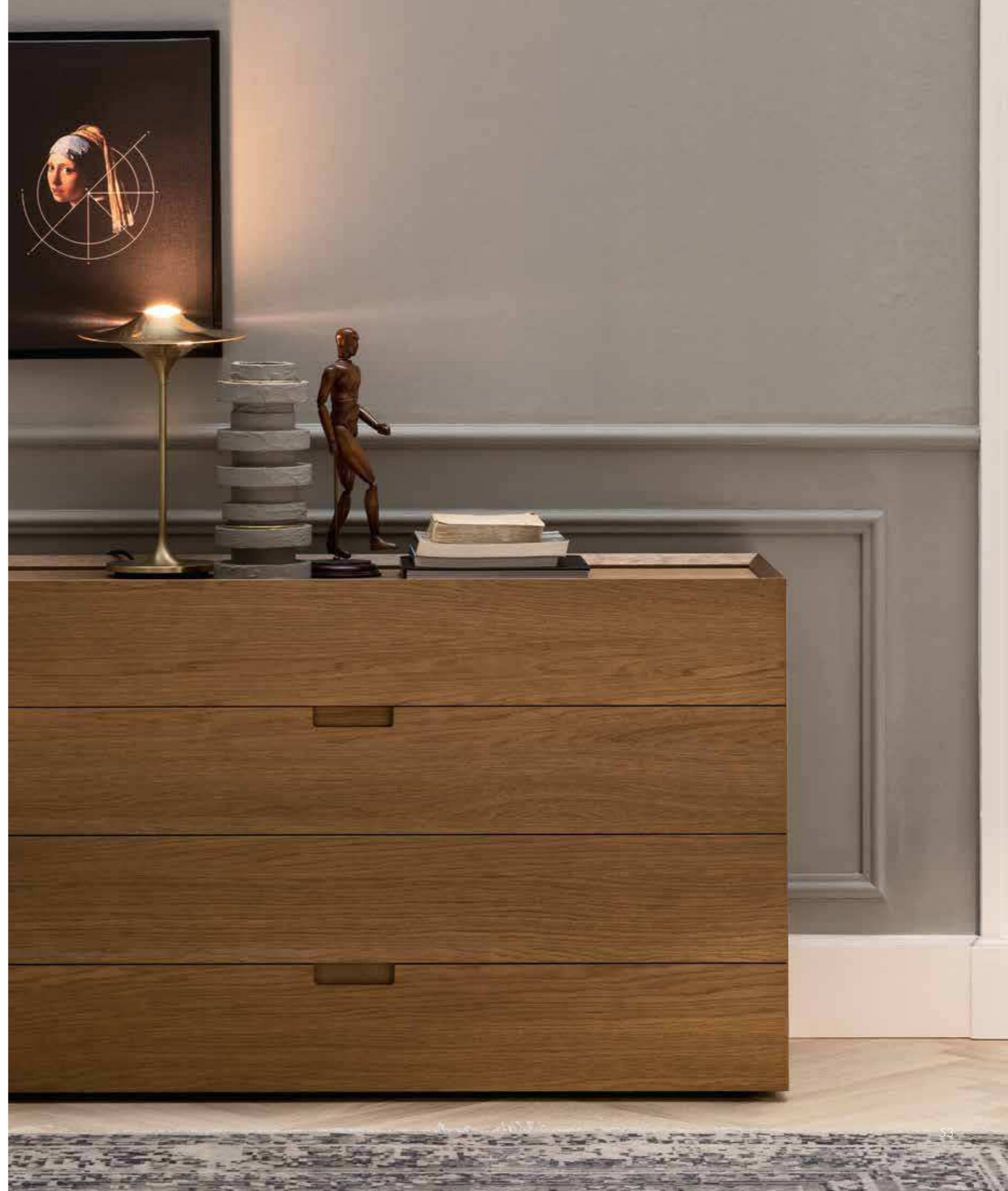



room 07

noah bed
norman collection

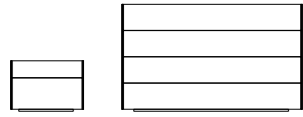
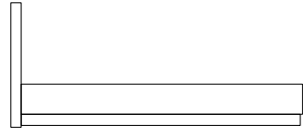

Sofisticato dal gusto retrò questo ambiente che ospita il letto Noah, caratterizzato dall'ampia testiera, ed il gruppo Norman.

An air of retro-flavoured sophistication pervades this room, home to the Noah bed, featuring a generously proportioned headboard, and Norman units.







Nella pagina a fianco comodino Norman in rovere miele e letto Noah, giroletto in finitura rovere rovere miele e testiera in tessuto schach 38. Qui a destra, particolare del piano in marmo di Carrara su comodino Norman in rovere miele. Sopra, testiera Noah in tessuto plug 11 con giroletto Omega in finitura rovere miele.

Opposite: Norman bedside table in rovere miele finish and Noah bed, surround in rovere miele finish and headboard in schach 38. This page, right: detail of Carrara marble top on Norman bedside table in rovere miele finish. Above: Noah headboard in plug 11 fabric with Omega bed surround in rovere miele finish.



room 08

modo bed
norman collection

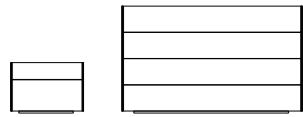
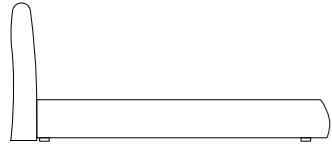

Contemporaneità con delle note classiche dettata dalle forme morbide del letto Modo e della collezione Norman.

Contemporary style with a smattering of classic notes dictated by the soft shapes of the Modo bed and Norman collection.







Nella pagina a fianco comò Norman in rovere terra con piano in marmo di Carrara.
A fianco, comodino Norman in finitura rovere terra con piano in marmo di Carrara.
Sotto, letto Modo in tessuto charlie 12.

*Opposite: Norman chest of drawers in rovere terra finish with Carrara marble top.
Right: Norman bedside table in rovere terra finish with Carrara marble top.
Below: Modo bed in charlie 12 fabric.*





room 09

brick bed
dotty collection

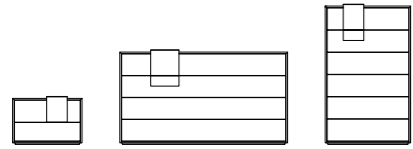
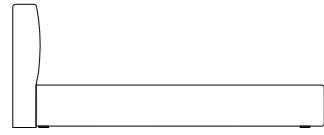

Freschezza e luminosità accolgono il letto Brick e la collezione Dotty in questa stanza dal sapore nordico.

A fresh, light and airy feel envelops the Brick bed and Dotty collection in this Nordic-inspired room.







Nella pagina a fianco comò collezione Dotty laccato bianco opaco con maniglia in rovere miele. In alto, dettaglio maniglia su comodino. A fianco, particolare letto Brick in tessuto maia 45.

Opposite: chest of drawers from the Dotty collection in bianco matt lacquered finish with handle in rovere miele. This page, top: detail of handle on bedside table. This page, left: detail of Brick bed in maia 45 fabric.



room 10

circe bed
dotty collection
middle wardrobe

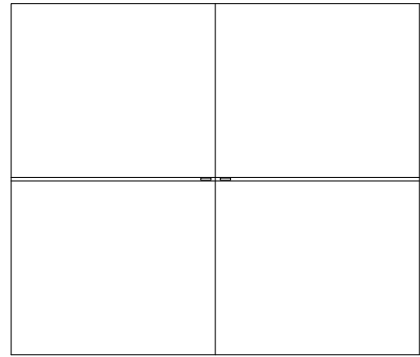
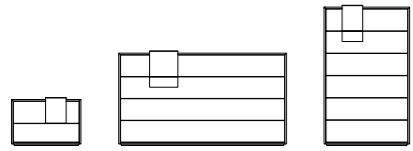
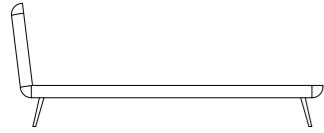

Dettagli preziosi e raffinate atmosfere avvolgono lo spazio caratterizzato dal letto Circe, dalla collezione Dotty e dall'armadio complanare con ante Middle.

Filled with precious details and a refined atmosphere, this space features the Circe bed, Dotty collection and wardrobe with flush-closing Middle doors.







Nella pagina precedente: letto Circe, dettaglio della testiera imbottita in tessuto patch 41 per l'interno e patch 37 per l'esterno.
A fianco, particolare del giroletto e gambe in rovere terra.
Sopra: variante monocromatica in tessuto patch 17.

*Opposite: Circe bed, detail of padded headboard upholstered in patch 41 fabric on the inside and patch 37 on the outside.
This page, left: detail of bed surround and legs in rovere terra finish.
Above: monochromatic version in patch 17 fabric.*



Comò Doty in laccato fango e maniglia in rovere terra. Nella pagina a fianco, armadio complanare con anta Middle in laccato quarzo opaco e maniglia in rovere terra.

Doty chest of drawers in fango lacquered finish and handle in rovere terra. Opposite: wardrobe with flush-closing Middle doors in quarzo matt lacquered finish and handle in rovere terra.



room 11

one bed
dotty collection

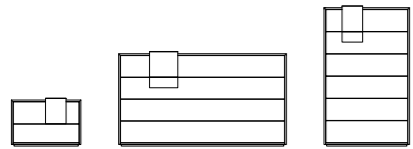
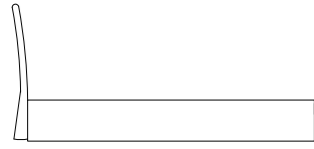

Originalità e personalizzazione caratterizzano gli elementi di questo ambiente in cui la collezione Dotty dialoga con il letto One.

The units in this room stand out for their originality and personal stamp, with pieces from the Dotty collection successfully teamed with the One bed.





Nella pagina precedente, letto One in tessuto tex 10 con cuciture tinta quarzo. Testiera disponibile in tre configurazioni di disegno cucitura. Nelle immagini, dall'alto: tessuto ginevra 01 con cucitura cascata, letto One con balza in tessuto ginevra 07 e cucitura visone, in fondo tessuto tex 10 e cucitura quarzo.

Opposite: One bed in tex 10 fabric with quarzo-coloured stitching. Headboard comes in a choice of three different stitching patterns. Pictured, from top: ginevra 01 fabric with cascata-coloured stitching; One bed with valance in ginevra 07 fabric and visone-coloured stitching; bottom, tex 10 fabric and quarzo-coloured stitching.



room 12

dream bed
pitagora collection

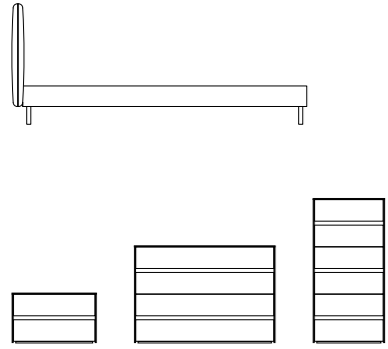

Dettagli ricercati, forme neutre e primarie caratterizzano il letto Dream e la collezione Pitagora.

Stylish details and neutral, primary shapes are the distinguishing features of the Dream bed and Pitagora collection.







Nella pagina a fianco, collezione Pitagora in finitura olmo ossido. Sopra e a lato, particolare giroletto e testiera del letto Dream in tessuto niles 06 con cucitura avio.

Opposite: Pitagora collection in olmo ossido finish. This page: details of Dream bed in niles 06 fabric with avio-coloured stitching.



room 13

sofly bed
pitagora collection
perry wardrobe

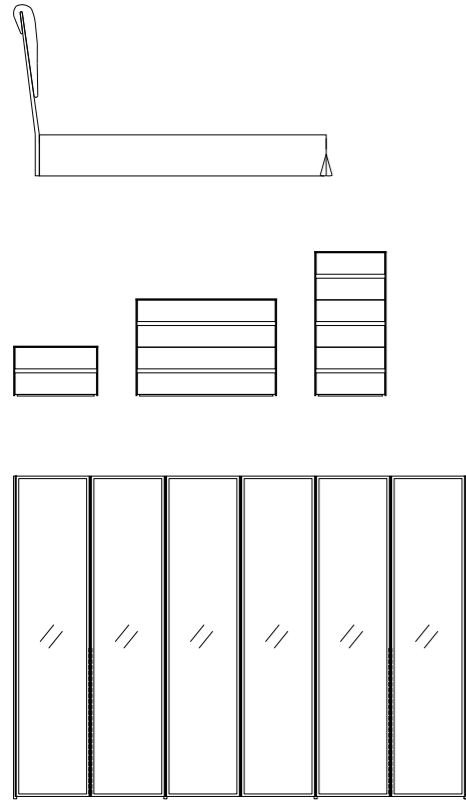

Pieni e vuoti si alternano in questo ambiente sofisticato che ha come protagonisti la collezione Pitagora, l'armadio Perry e il letto Softy in tessuto maia 28.

The Softy bed in maia 28 fabric, Pitagora collection and Perry wardrobe take centre stage in this sophisticated room with its alternating solid elements and voids.







Nella pagina precedente, comò della collezione Pitagora in olmo scuro.
Sopra, letto Softy variante bicolore in tessuto maia 17 interno e maia 45 esterno.
A destra, settimanale Pitagora in finitura cenere con gola oceano.



Opposite: chest of drawers from the Pitagora collection in olmo scuro finish.
This page, above: Softy bed in 2-tone version in maia 17 fabric on the inside and maia 45 on the outside.
This page, right: Pitagora tallboy in cenere finish with oceano-coloured profile.





Nella pagina a fianco armadio con anta Perry, in vetro fumè e telaio brunito.
In alto, particolare del tubo appendiabiti in finitura brunita.

*Opposite: wardrobe with smoked glass Perry door with frame in bronze finish.
This page, top: detail of hanging rail with bronze frame.*





room 14

ariel bed
overlap collection

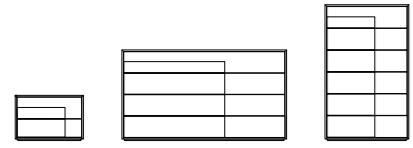

Letto Ariel e collezione Overlap inseriti in un ambiente eclettico e contemporaneo.

The Ariel bed and Overlap collection are set in an eclectic, contemporary interior.







In alto, particolare testiera letto Ariel in tessuto klaus O6.
A fianco e nella pagina seguente, comodino e coppia di settimanali della collezione Overlap in laccato cenere opaco.

*This page, top: detail of Ariel bed headboard in klaus O6 fabric.
Left and opposite: bedside table and pair of tallboys from the Overlap collection in lacquer finish.*

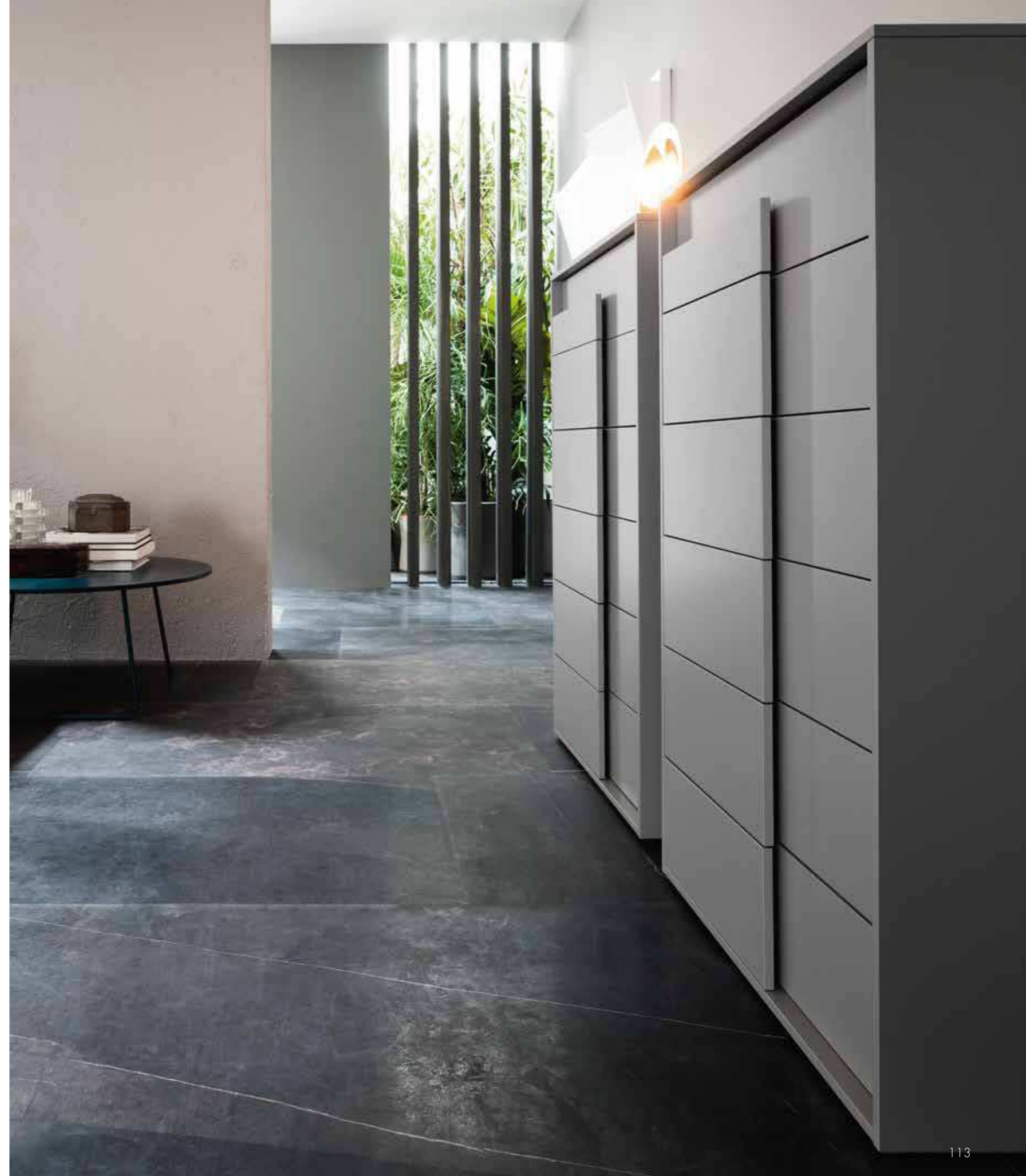

room 15

dodo bed
overlap collection
liberty wardrobe

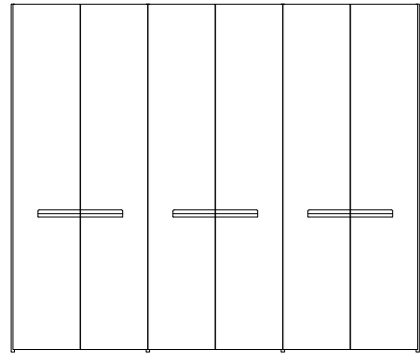
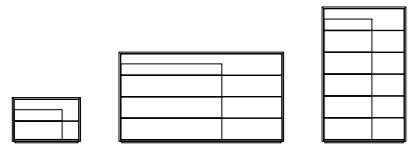

Letto Dodo, collezione Overlap e armadio Liberty creano un ambiente minimal ed elegante, equilibrato nei toni e nelle cromie.

The Dodo bed, Overlap collection and Liberty wardrobe create an elegant, minimal interior with well balanced tones and colours.







A fianco, particolare dell'innesto tra testiera e giroletto del letto Dodo.
A destra, comò Overlap, finitura rovere gessato. Sopra: letto Dodo in rovere gessato.



Opposite: detail of Dodo bed where the headboard meets the bed surround. This page, right: Overlap chest of drawers, rovere gessato finish. This page, above: Dodo bed in rovere gessato finish.





Anta Liberty per armadio battente, in laccato opaco foglia.
Attrezzatura interna brunita.

*Liberty door for hinged door wardrobe, in foglia matt lacquered finish.
Internal fittings in bronze finish.*





room 16

dedalo bed
globe collection

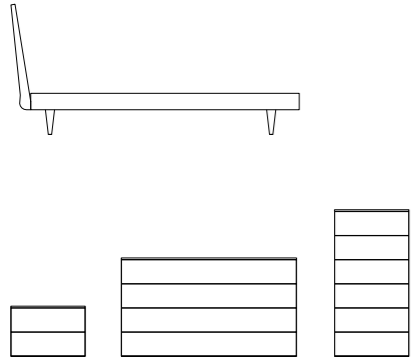

Ricerca estetica basata sulla semplicità ed essenzialità per il letto Dedalo e la collezione Globe.

A simple, pared-back aesthetic is evident in the design of the Dedalo bed and Globe collection.







In questa pagina, collezione Globe in finitura olmo scuro, sopra: comò, a fianco: dettaglio apertura cassetto comodino.
 In basso, letto Dedalo con giroletto Kappa contenitore, in finitura olmo scuro.
 Nella pagina accanto, innesto testiera letto Dedalo con giroletto Omega in olmo scuro.

Globe collection in olmo scuro finish, chest of drawers and detail of opened bedside table drawer.
Below: Dedalo bed with Kappa bed surround with storage base, in olmo scuro finish.
Opposite: detail of bed where the headboard meets the bed surround.



room 17

bend bed
globe collection

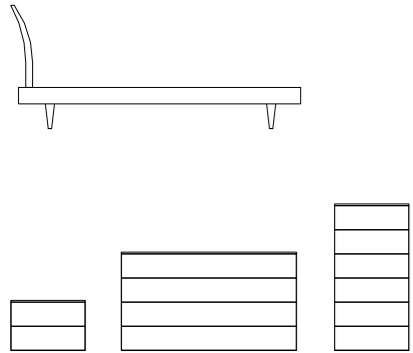

Linee pulite e proporzioni armoniose sono il tratto distintivo di questa composizione formata da letto Bend e collezione Globe.

Clean lines and harmonious proportions are the distinguishing trait of this composition made up of the Bend bed and Globe collection.







A sinistra, settimanali della collezione Globe in finitura rovere gessato. A lato dettaglio gola laterale per presa maniglia. Sotto, letto Bend in finitura rovere gessato.

Opposite: tallboys from the Globe collection in rovere gessato finish. This page, right: detail of channel on side acting as edge pull. This page, below: Bend bed in rovere gessato finish.





room 18

sheet bed
easy collection
allout collection

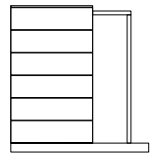
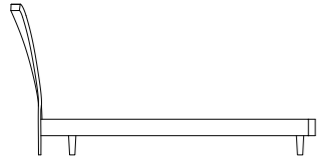

Uno scenario underground in cui il letto Sheet e la collezione Easy disegnano geometrie e pratiche funzioni.

The underground vibe in this room stems from the Sheet bed and Easy collection with their geometric design and practical function.







In questa pagina e a fianco: elemento Easy Plus in finitura laccato opaco foglia con tubo brunito a funzione di servetto.
Sopra, particolare testiera del letto Sheet in finitura olmo chiaro.



This page and opposite: Easy Plus unit in foglia matt lacquered finish with bronze-finish tube acting as a hanging rail.
This page, top: detail of Sheet bed headboard in olmo chiaro finish.



room 19

time bed
easy collection

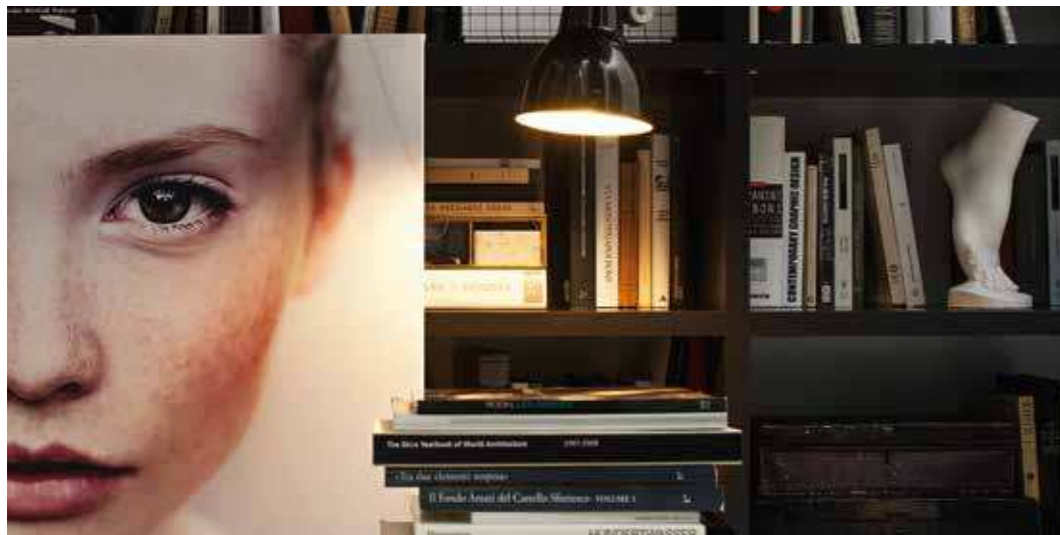
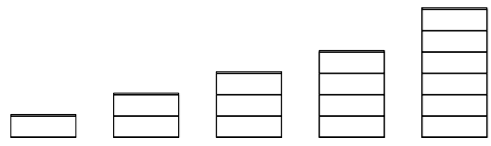
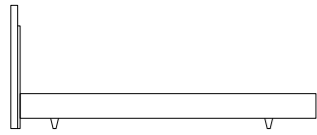

In questo spazio dinamico e contemporaneo si riconoscono la collezione Easy ed il letto Time in finitura olmo ossido e laccato opaco cenere.

The Time bed, in olmo ossido and cenere matt lacquered finishes, and Easy collection stand out in this dynamic, contemporary space.







A fianco e nella pagina precedente, flessibilità di composizione della collezione Easy in finitura olmo ossido e laccato opaco cipria. Sopra variante letto Time con giroletto contenitore con meccanismo Simple, in tessuto feltro 30, testiera olmo chiaro e feltro 30.

Left and opposite: the Easy collection's flexible configuration options are showcased with units pictured in olmo ossido and cipria matt lacquered finishes. Above: Time bed in version with storage base featuring Simple mechanism, upholstered in feltro 30 fabric, headboard in olmo chiaro finish and feltro 30.

room 20

nido bed
easy collection
alfa wardrobe

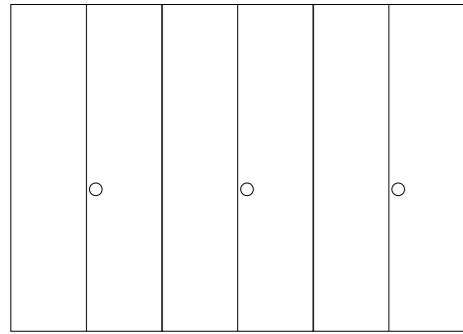
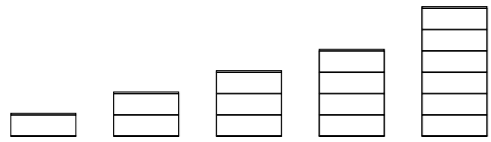

Essenziale e sobrio questo spazio notte, composto da letto Nido, collezione Easy e armadio Alfa battente con maniglia Stone in marmo di Carrara.

An unfussy, low-key bedroom space comprising the Nido bed, Easy collection and Alfa hinged door wardrobe with Stone handle in Carrara marble.







A fianco, letto Nido con testiera in tessuto ginevra 06 e giroletto laccato opaco bianco.
In questa pagina, gruppo Easy sospeso, in finitura laccato opaco caffè.

Opposite: Nido bed with headboard in ginevra 06 fabric and bed surround in bianco matt lacquered finish.
This page: wall-mounted Easy unit in caffè matt lacquered finish.





Armadio Alfa battente, laccato opaco bianco, con maniglia Stone in marmo di Carrara.
Attrezzatura interna in finitura brunito.

*Alfa hinged door wardrobe, bianco matt lacquered finish, with Stone handle in Carrara marble.
Internal fittings in bronze finish.*



room 21

twiggy bed
easy collection
allout collection

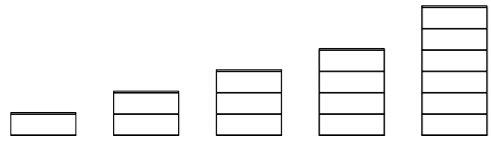
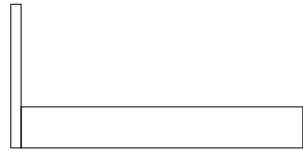

Atmosfere naturali e sensazioni materiche fanno da cornice al letto Twiggy ed alla collezione Easy.

The room occupied by the Twiggy bed and Easy collection is a study in texture permeated by a natural atmosphere.







Pagina accanto, particolare letto Twiggy in tessuto klaus 10.
A sinistra, configurazione gruppo Easy con panca e cassetti in appoggio sfalsati in finitura laccato opaco fango.
Sopra, comodino Allout in finitura ocra.

*Opposite: detail of Twiggy bed in klaus 10 fabric.
Left: Easy units in an offset arrangement comprising drawers sitting on top of a bench in fango matt lacquered finish.
Top, Allout bedside table in ocra finish.*

room 22

line bed
easy collection

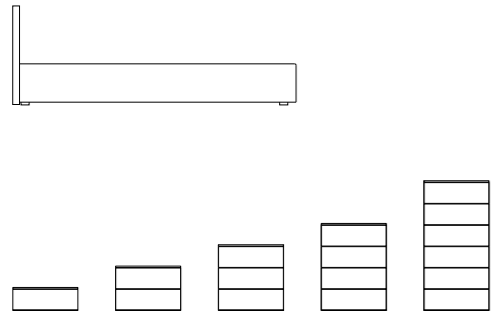

Letto Line e collezione Easy in una composizione moderna e versatile dai toni ricercati e geometrici.

The Line bed and Easy collection feature in a modern, versatile arrangement with a refined, geometric style.







In questa pagina, in alto: doppio comò Easy in finitura laccato opaco artico. Sotto, letto Sommier con contenitore e dettaglio della testiera Line in laccato visone e tessuto ginevra 07.
Nella pagina a fianco dettaglio della mensola ad L per testiera Line.

*This page, top: pair of Easy chests of drawers in artico matt lacquered finish. Below: Sommier storage bed and detail of Line headboard in visone lacquered finish and ginevra 07 fabric.
Opposite: detail of L-shaped shelf for Line headboard.*

TECHNICAL

Finiture
Dettagli tecnici

*Finishes
Technical details*

Impiallacciato/Veneers



85 rovere miele 87 rovere terra

Ecolegno/Eco-wood



71 rovere gessato 79 olmo chiaro 83 olmo ossido 80 olmo scuro

Materico/Textured



85 rovere bianco 87 rovere tortora

Laccato Opaco/Matt Lacquered



300 bianco 301 avorio 303 tortora 314 corda 333 sabbia 331 visone 340 caffè



330 grigio 341 cenere 324 fango 310 quarzo 318 nero grafite 339 artico 344 avio



325 oceano 334 cascata 342 foglia 337 oca 335 tangeri 321 rosso 343 cipria

Laccato Lucido/Gloss Lacquered



400 bianco lucido 401 avorio lucido 403 tortora lucido 414 corda lucido 433 sabbia lucido 440 caffè lucido 430 grigio lucido



441 cenere lucido 410 quarzo lucido 418 nero grafite lucido 439 artico lucido 444 avio lucido 434 cascata lucido 421 rosso lucido

Tessuti/Fabrics



charlie 5 colori/ 5 colours maia 13 colori/ 13 colours slim ecopelle 13 colori/ 13 colours tex 9 colori/ 9 colours adams 8 colori/ 8 colours artù ecopelle 13 colori/ 13 colours giovè 12 colori/ 12 colours



joint 9 colori/ 9 colours lucky 9 colori/ 9 colours luxor 13 colori/ 13 colours schach 11 colori/ 11 colours tilt 10 colori/ 5 colours ginevra 11 colori/ 11 colours klaus 11 colori/ 11 colours



milo 11 colori/ 11 colours patch 13 colori/ 13 colours lab feltro 13 colori/ 13 colours lab plug 3 colori/ 3 colours lab trace 4 colori/ 4 colours nils pelle 12 colori/ 12 colours ares pelle 12 colori/ 12 colours

Letti/Beds

Siri

p. 10

design by Studio Gherardi

Letto con struttura in impiallacciato, disponibile in rovere miele e rovere terra.

Bed with veneered frame, available in rovere miele and rovere terra.

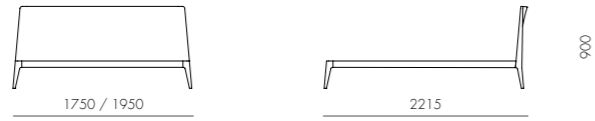

Siri Soft

p. 16

design by Studio Gherardi

Letto con struttura in impiallacciato, disponibile in rovere miele e rovere terra, e coprifestiera in tessuto, ecopelle o pelle.

Bed with veneered frame, available in rovere miele and rovere terra, and headboard cover in fabric, imitation leather or leather.

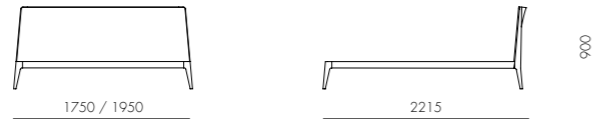

Grace

p. 48

design by Studio Gherardi

Letto con struttura in impiallacciato, disponibile in rovere miele e rovere terra.

Bed with veneered frame, available in rovere miele and rovere terra.

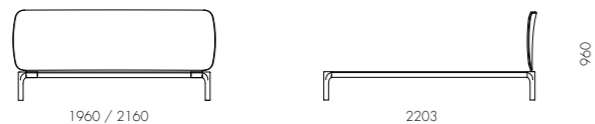

Kalé

p. 32

design by Studio Gherardi

Letto con testiera in tessuto, ecopelle o pelle. Giroletto con piedini disponibile in impiallacciato o laccato opaco. Giroletto con contenitore impiallacciato disponibile con meccanismo Simple o materasso annegato.

Bed with headboard in fabric, imitation leather or leather. Bed surround with feet in choice of veneer or matt lacquered finish. Bed surround with veneered storage base with Simple mechanism or partially recessed mattress.



Noah

p. 56

design by Studio Gherardi e Nova Lab

Letto con testiera in tessuto. Giroletto con contenitore impiallacciato disponibile con meccanismo Simple o materasso annegato. Giroletto con piedini disponibile in impiallacciato o laccato opaco.

Bed with fabric headboard. Bed surround with veneered storage base with Simple mechanism or partially recessed mattress. Bed surround with feet in choice of veneer or matt lacquered finish.

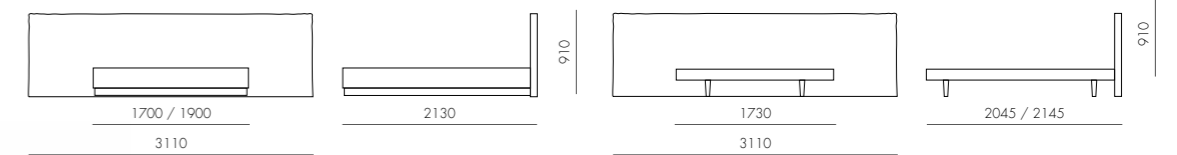

Park

p. 42

design by Studio Gherardi

Letto con struttura in impiallacciato, disponibile in rovere miele e rovere terra con testiera in tessuto, ecopelle o pelle.

Bed with veneered frame, available in rovere miele and rovere terra, and headboard in fabric, imitation leather or leather.



Brick

p. 70

design by Nova Lab

Letto imbottito, disponibile in tessuto, ecopelle o pelle.

Padded bed, available in fabric, imitation leather or leather.

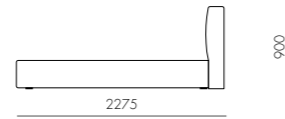
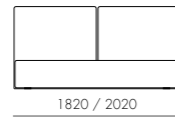

Circe

p. 76

design by Studio Gherardi

Letto imbottito con piedino in legno disponibile in tessuto ed ecopelle in tinta unita o bi-colore o in pelle in tinta unita.

Padded bed with wooden feet, available in fabric or imitation leather - in choice of plain or 2-tone option - or in plain-coloured leather.

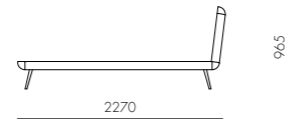
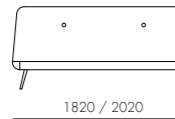

Dream

p. 92

design by Studio Gherardi

Letto imbottito con piedini in metallo, disponibile in tessuto, ecopelle o pelle; cucitura personalizzabile in 5 colori.

Padded bed with metal feet, available in fabric, imitation leather or leather; stitching in your choice of 5 colours.

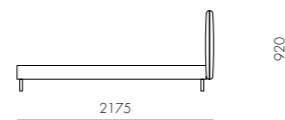
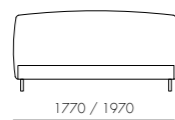

Margot

p. 26

design by Nova Lab

Letto imbottito con piedini in metallo, disponibile in tessuto, ecopelle o pelle.

Padded bed with metal feet, available in fabric, imitation leather or leather.

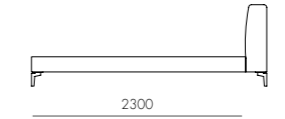
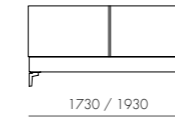

Modo

p. 62

design by Nova Lab

Letto imbottito, disponibile in tessuto, ecopelle o pelle.

Padded bed, available in fabric, imitation leather or leather.

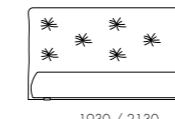

One

p. 84

design by Studio Gherardi e Nova Lab

Letto imbottito, disponibile in tutti i tessuti. Cuciture personalizzabili in tre configurazioni, disponibili in tutti i colori.

Padded bed, available in all fabrics. Stitching in your choice of three different patterns, available in all colours.

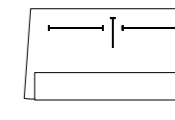
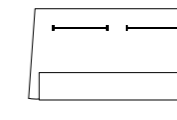
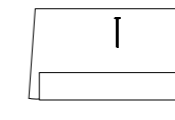
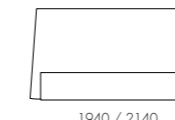

Softy

design by Studio Gherardi

p. 98

Letto imbottito, disponibile in tutti i tessuti, con configurazione anche bicolor.

PadDED bed, available in all fabrics, with 2-tone option also available.

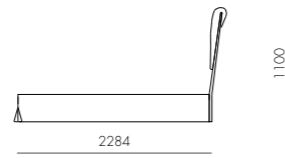
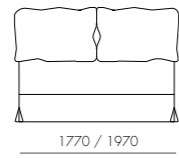

Twiggy

design by Nova Lab

p. 160

Letto imbottito, disponibile in tutti i tessuti, cuciture disponibili in tutti i colori.

PadDED bed, available in all fabrics, stitching available in all colours.

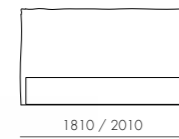

Ariel

design by Nova Lab e Studio Gherardi

p. 108

Letto con struttura con piedini o contenitore in melaminico, disponibile nelle finiture ecolegno, materico e laccato opaco in tutti i colori. Testiera disponibile in tessuto, ecopelle o pelle.

Bed with melamine frame on feet or storage base, available in eco-wood, textured and matt lacquered finishes in all colours. Headboard available in fabric, imitation leather or leather.

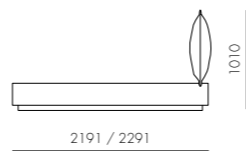
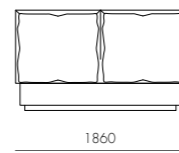
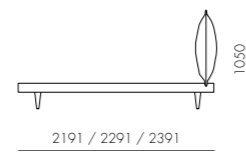
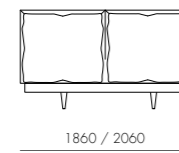

Bend

design by Nova Lab

p. 130

Letto con struttura con piedini o contenitore in melaminico, disponibile nelle finiture ecolegno, materico e laccato opaco in tutti i colori.

Bed with melamine frame on feet or storage base, available in eco-wood, textured and matt lacquered finishes in all colours.

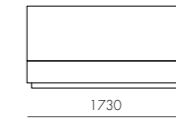
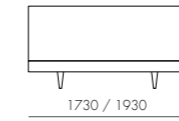

Dedalo

design by Nova Lab

p. 124

Letto con struttura con piedini o contenitore in melaminico, disponibile nelle finiture ecolegno e materico.

Bed with melamine frame on feet or storage base, available in eco-wood and textured finishes.

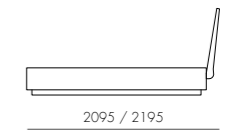
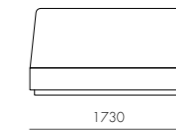
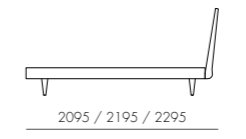
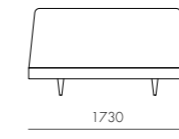

Dodo

design by Studio Gherardi

p. 114

Letto con struttura in melaminico, disponibile nelle finiture ecolegno.

Bed with melamine frame, available in eco-wood finishes.

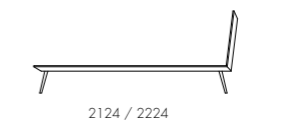
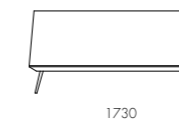

Nido

p. 150

design by Nova Lab

Letto con struttura con piedini o contenitore in melaminico, disponibile nelle finiture ecolegno, materico e laccato opaco in tutti i colori, e testiera disponibile in tessuto, ecopelle o pelle.

Bed with melamine frame on feet or storage base, available in eco-wood, textured and matt lacquered finishes in all colours; and upholstered headboard available in fabric, imitation leather or leather.

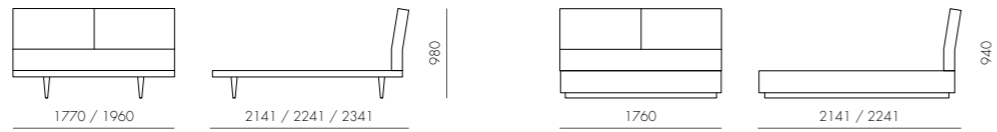

Sheet

p. 138

design by Studio Gherardi

Letto con struttura in melaminico, disponibile nelle finiture ecolegno.

Bed with melamine frame, available in eco-wood finishes.



Time

p. 144

design by Nova Lab

Letto con struttura e testiera disponibili nelle finiture ecolegno, materico, in tessuto, ecopelle e laccato opaco in tutti i colori.

Bed with frame and headboard available in a choice of finishes: eco-wood, textured, fabric, imitation leather and matt lacquered finishes in all colours.

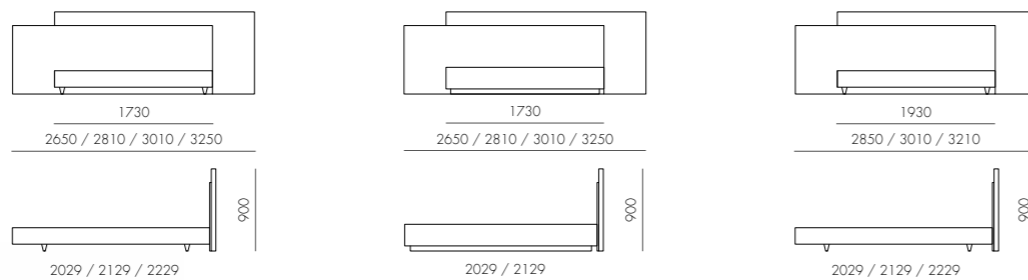

Line

p. 166

design by Nova Lab

Letto con struttura e testiera disponibili nelle finiture ecolegno, materico, in tessuto, ecopelle e laccato opaco in tutti i colori.

Bed with frame and headboard available in a choice of finishes: eco-wood, textured, fabric, imitation leather and matt lacquered finishes in all colours.

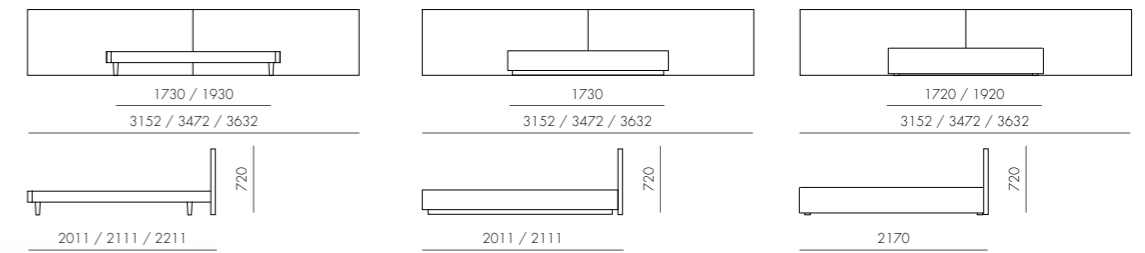

Form

design by Nova Lab

Giroletto imbottito componibile con testiera, schienale e fianchi disponibile in tessuto o ecopelle.

Padded bed surround available with headboard, back and sides available in fabric and imitation leather.

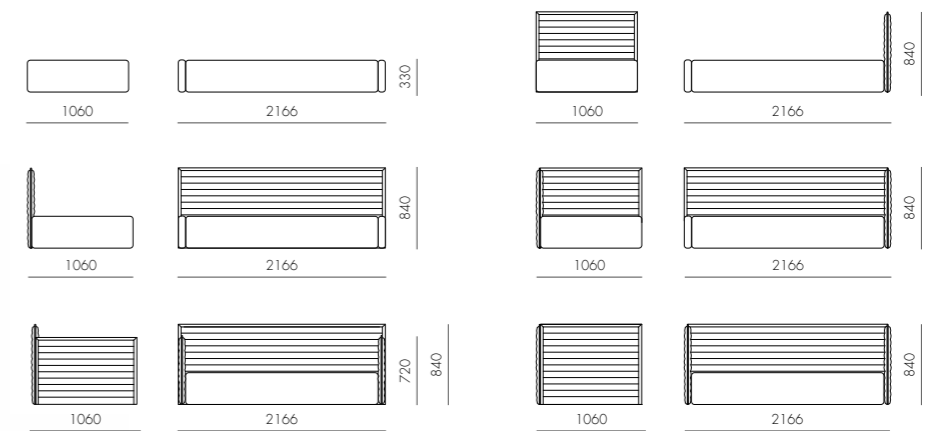

Collezioni/Collections

Giotto p. 10 / 16
design by Nova Lab

Collezione notte disponibile in rovere miele e rovere terra.

Bedroom collection available in rovere miele and rovere terra.

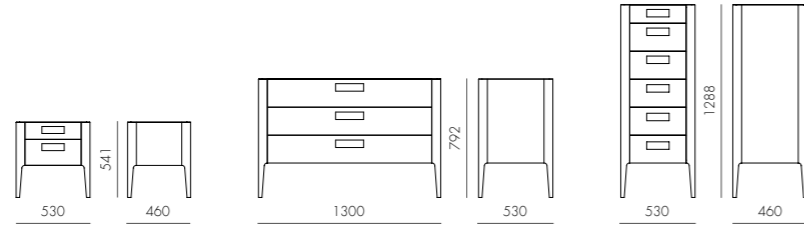

Platone p. 26 / 32
design by Studio Gherardi

Collezione notte disponibile in rovere miele e rovere terra.

Bedroom collection available in rovere miele and rovere terra.

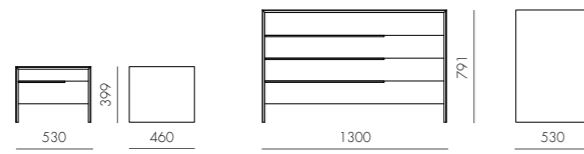

Quarantacinque p. 42 / 48
design by Studio Gherardi

Collezione notte disponibile in rovere miele e rovere terra, con piano disponibile in vetro laccato.

Bedroom collection available in rovere miele and rovere terra, with top available in lacquered glass.

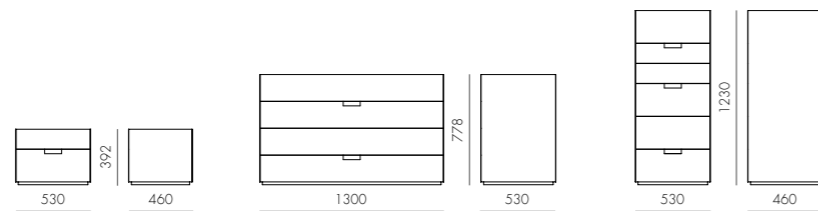

Norman p. 56 / 62
design by Nova Lab

Collezione notte disponibile in rovere miele e rovere terra, con piano disponibile in marmo di Carrara.

Bedroom collection available in rovere miele and rovere terra, with top available in Carrara marble.



Allout p. 138 / 160
design by Nova Lab

Tavolino disponibile in laccato opaco 21 colori.

Occasional table available in matt lacquered finish in choice of 21 colours.

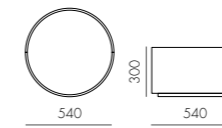

Pitagora p. 92 / 98
design by Nova Lab e Studio Gherardi

Collezione notte disponibile nelle finiture ecolegno, materico e laccato opaco in tutti i colori.

Bedroom collection available in textured, eco-wood and matt lacquered finishes in all colours.

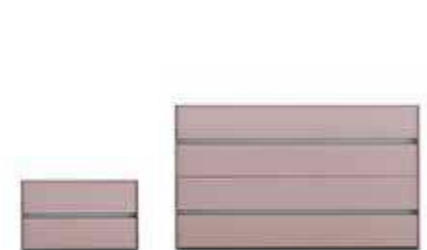
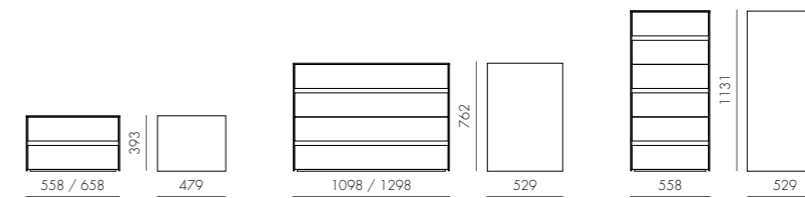

Overlap p. 108 / 114
design by Molteni e Morelli

Collezione notte disponibile nelle finiture materico, ecolegno e laccato opaco in tutti i colori.

Bedroom collection available in textured, eco-wood and matt lacquered finishes in all colours.

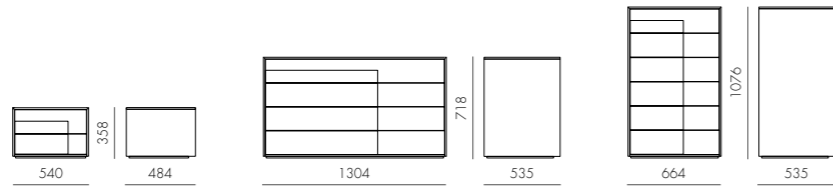

Dotty p. 70 / 76 / 84
design by Molteni e Morelli

Collezione notte disponibile nelle finiture materico, ecolegno e laccato opaco in tutti i colori, con maniglia in metallo bianco, brunito, laccato opaco, o in legno rovere miele, rovere terra.

Bedroom collection available in textured, eco-wood and matt lacquered finishes in all colours, with metal handle in white, bronze finish or matt lacquered, or wooden handle in rovere miele or rovere terra.

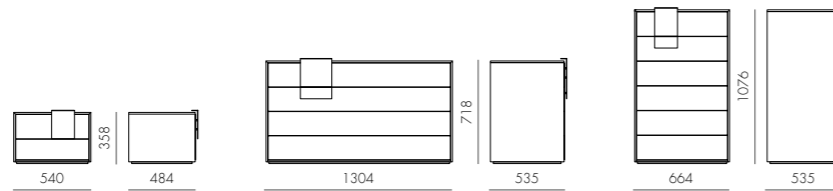

Globe p. 124 / 130
design by Nova Lab

Collezione notte disponibile nelle finiture materico ed ecolegno.

Bedroom collection available in textured and eco-wood finishes.

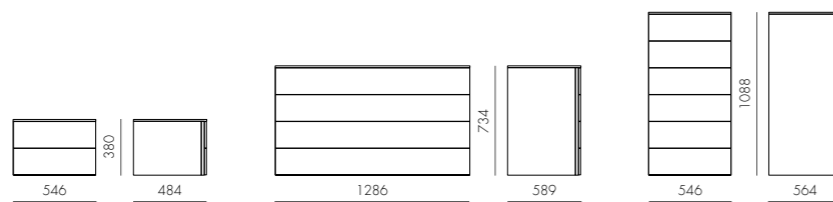

Easy p. 138 / 144 / 150 / 160 / 166
design by Nova Lab

Collezione notte disponibile nelle finiture ecolegno, materico, e laccato opaco e lucido in tutti i colori.

Bedroom collection available in eco-wood, textured and matt and gloss lacquered finishes in all colours.

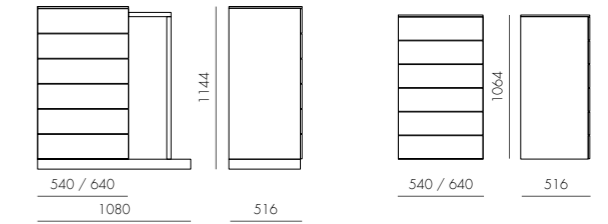
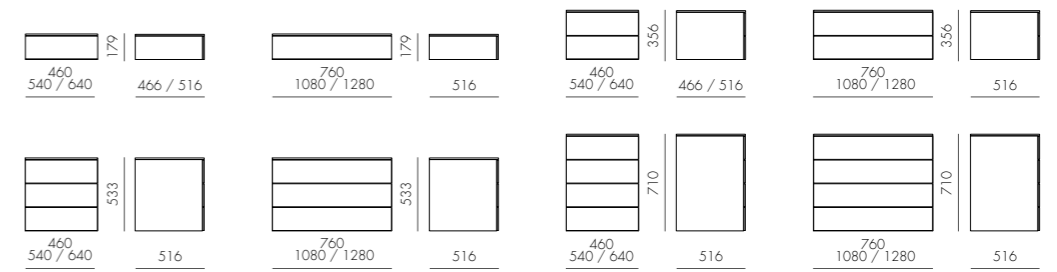

Vernici all'Acqua

95% di emissioni in meno.

Novamobili si impegna per ridurre al massimo l'impatto dei propri processi produttivi sull'ambiente.

Con questo intento ha messo a punto un esclusivo sistema di laccatura opaca all'acqua, che rappresenta oggi la risposta più avanzata in tema di rispetto della natura, di tutela della salute e di qualità del prodotto. Con questa finitura ecologica, si riduce di oltre il 95% l'emissione di solventi inquinanti in atmosfera. Questo tutela la salute non solo di coloro che fabbricano i prodotti, ma anche delle persone che con i mobili convivono; per la sicurezza dei più piccoli, è utile sapere che in caso di contatto con la bocca, le vernici all'acqua non sono nocive, nel rispetto della rigorosa Norma Europea EN 71.3.

Il bello dell'ecologia.

Le vernici a base d'acqua, applicate con impianti moderni ed efficienti, offrono una resa superiore alle vernici tradizionali: le superfici trattate si presentano distese, morbide al tatto e mantengono un'ottima brillantezza dei colori nonché una eccezionale durezza e resistenza chimico-fisica della finitura nel tempo.

Water-based paints

95% less emissions.

Novamobili is committed to reducing the impact of its production processes on the environment as much as possible.

To this end, we have devised an exclusive water-based matt lacquering system that today represents the most advanced solution in terms of conservation, health protection and product quality. Using this environmentally friendly finish reduces the emission of polluting solvents into the atmosphere by over 95%. This protects not only the health of those involved in manufacturing, but also of the people who live with the furniture produced; parents will find it reassuring to know that, in compliance with the strict European standard EN 71.3, water-based paints are not harmful when they come into contact with little mouths.

The beauty of eco-awareness.

Water-based paints, applied with efficient modern equipment, give much better results than traditional paints: the treated surfaces are smooth, soft to the touch and maintain excellent colour brilliance, while producing a finish with exceptional lasting hardness and chemical and physical resistance.

Carta FSC®

La cellulosa contenuta in questo catalogo proviene da foreste correttamente gestite, certificate in maniera indipendente in conformità alle norme del Forest Stewardship Council®.



Environmentally Friendly Paper

The cellulose contained in this catalogue comes from correctly managed forests that are independently certified in conformity with Forest Stewardship Council® standards.

Pannello Ecologico

Coltiviamo la salute del pianeta.

Novamobili utilizza pannelli nobilitati atossici nel pieno rispetto della normativa Europea classe E1. Il Pannello Ecologico è realizzato esclusivamente con il reimpiego di legno, mediante un processo produttivo di qualità certificata che rispetta l'ambiente perchè non comporta l'abbattimento di alberi.



Eco panel

Taking care of the health of the planet.

Novamobili uses non-toxic foil-wrapped panels to European class E1. Our Eco Panel is made entirely of recycled wood by a quality-certified production process that is environmentally friendly as it does not involve felling trees.

Ringraziamenti
Acknowledgements

art direction
photos
styling
photo litography
printing
date

studio gherardi
studio pitari
luigina pilloni
lucegroup
lucegroup
gennaio 2016

thanks to:

a+a lab
all'origine
bert frank
cecchi & cecchi
coraxart
gandia blasco
kandahar
idea group divisione bagni
indikon
intuerilight
la maison de vacances
muubs
pulpo

atmosphere photos:

Andrea Adriani
(p. 54)
Giovanni Vecchiato
(p. 8/ 90/ 158)
Marco Gennato
(p. 24/ 40/ 68/ 106/ 122/ 136)

Novamobili si riserva in qualsiasi momento la facoltà di apportare tutte le modifiche necessarie al miglioramento funzionale e qualitativo dei propri prodotti. Per ogni aspetto tecnico e dimensionale fare riferimento ai listini aziendali e relativi aggiornamenti. I colori e i materiali riprodotti nelle immagini stampate hanno un valore indicativo.

In line with its policy of improving product function and quality, Novamobili reserves the right to make any necessary changes at any time. For information of a technical and dimensional nature, refer to the company prices lists and relevant updates. The colours and materials reproduced in the images printed herein are given as an approximate guide only.

Novamobili S.p.a.
Via Pascoli, 14
31053
Pieve di Soligo (TV)
Italia

Tel. +39 0438 9868
Fax +39 0438 986999

novamobili@novamobili.it
novamobili.it

b



novamobili.it

Novamobili S.p.a.
via Pascoli, 14
Pieve di Soligo (TV)
31053 Italia
Tel. + 39 0438 9868
Fax + 39 0438 986999
novamobili@novamobili.it